

**CASE NO. 24-0166-GA-BNR  
CONSTRUCTION NOTICE FOR  
PIR 2788 – APPLE CREEK (2024) PIPELINE REPLACEMENT PROJECT**

**Construction Notice for  
PIR 2788 – Apple Creek (2024)  
Pipeline Replacement Project  
Wooster Twp, Wayne County, Ohio  
For Existing Pipeline Replacement**

**Ohio Power Siting Board  
Case No. 24-0166-GA-BNR**

**Submitted by**  
**The East Ohio Gas Company d/b/a Dominion Energy Ohio**  
Project #P40080793 MWO#64036806

**CASE NO. 24-0166-GA-BNR**  
**CONSTRUCTION NOTICE FOR**  
**PIR 2788 – APPLE CREEK (2024) PIPELINE REPLACEMENT PROJECT**

The following information is being submitted in accordance with Ohio Administrative Code (OAC) Chapter 4906-6-05, Accelerated Application Requirements.

**4906-6-05(B)(1): Name and Reference Number**

The applicant is the East Ohio Gas Company d/b/a Dominion Energy Ohio (“DEO”). The name of the pipeline replacement project is PIR 2788 – Apple Creek (2024) Pipeline Replacement Project. The internal project numbers are P400243860 and master work order (“MWO”) 63449624.

**4906-6-05(B)(1): Brief Description of Project**

This project involves the replacement of approximately 3,100 feet of existing 12-inch pipeline with approximately 3,880 feet of 12-inch diameter and 20 feet of 16-inch diameter fusion bond epoxy (“FBE”) steel pipeline. The existing pipeline will be abandoned in place. The project is located within Wooster Township in Wayne County, Ohio. A Google Earth project map which shows streets and existing pipelines is included as **Attachment A**.

**4906-6-05 (B)(1): Why the Project Meets the Requirements for a Construction Notice**

This project qualifies as a Construction Notice Application under OAC Rule 4906-1-01, Appendix B (1)(a) because it involves the replacement of an existing pipeline segment of less than 1 mile in length.

**4906-6-05 (B)(2): Statement of Need for the Proposed Facility**

DEO is undertaking this project to maintain pipeline integrity, enhance public safety, and continue to assure safe, adequate, and reliable natural gas supply to DEO’s customers. A section of this pipeline replacement is uncoated bare steel, which is more susceptible to corrosion and leaks than coated pipe.



**CASE NO. 24-0166-GA-BNR  
CONSTRUCTION NOTICE FOR  
PIR 2788 – APPLE CREEK (2024) PIPELINE REPLACEMENT PROJECT**

As shown in the table below, the existing steel mainline has 3,100 feet of pipe that is between 60 and 68 years old:

Year Installed	Distance of Pipeline Segment to be Replaced (ft.)	Existing Size and Type	Coating	Disposition
1956	1345	12" 0.375 wall Steel	None	To be retired
1961	158	12" 0.281 wall Steel	Tarred and Wrapped	To be retired
1964	1597	12" 0.219 wall Steel	Tarred and Wrapped	To be retired

The pipeline segments indicated above are part of Canton WOH6, a high-pressure trunk line. This is a single feed high-pressure supply line to approximately 20,000 customers in the City of Wooster, Union Township, Paint Township, and the Cities of Shreve, Loudonville and Brinkhaven. The pipeline is supplied by Five Points Regulating Station.

**4906-6-05(B)(3): Location of the Project**

**Attachment A** contains an area system map showing the location of the replacement pipeline in relation to existing lines and substations. The project is located within the boundaries of Wooster Township, Wayne County, Ohio.

**4906-6-05(B)(4): Alternatives Considered**

Where possible, DEO prefers to install replacement pipeline within existing easements and rights of way. For this project, a portion of the replacement pipe (approximately 1,000 feet) will be installed in the existing right-of-way, and the remainder relocated to newly acquired right of way. This decision was made because of the steepness

**CASE NO. 24-0166-GA-BNR**  
**CONSTRUCTION NOTICE FOR**  
**PIR 2788 – APPLE CREEK (2024) PIPELINE REPLACEMENT PROJECT**

and complexity of the terrain in the existing pipeline corridor. DEO's analysis of the project area revealed that construction within the sloped area south of the stream depicted in Attachment A posed a high risk of uncontrolled debris and contamination falling into the stream and adjacent wetlands. DEO determined that this risk is best mitigated by re-routing this portion of the pipeline closer to the stream and open cutting a new trench, which will allow DEO to better control disturbances and contamination in the project area.

**4906-6-05(B)(5): Description of Public Information Program**

A pre-construction letter (**Attachment C**) to be sent to affected property owners and tenants listed on Attachment B at least 7 days prior to construction, as required under Rule 4906-6-11 (C).

**4906-6-05(B)(6): Anticipated construction schedule, in-service date**

The construction of the replacement pipeline is anticipated to begin in Summer 2024. DEO plans to place the line in-service and complete restoration activities by the end of 2024.

**4906-6-05(B)(7): Project Area Map and Directions**

An area map that is at least of a 1:24000 scale that depicts roads, streets and highways is attached as **Attachment A**.

**4906-6-05(B)(8): Easements, Options and/or Land Use Agreements**

The project is partially within DEO's existing easements and road right-of-way. DEO has obtained an additional easement to construct the segment of the replacement pipe being relocated from the sloped area, as explained above.

**4906-6-05(B)(9)(a): Technical Features of the Project**

**CASE NO. 24-0166-GA-BNR**  
**CONSTRUCTION NOTICE FOR**  
**PIR 2788 – APPLE CREEK (2024) PIPELINE REPLACEMENT PROJECT**

DEO will utilize open trenches to install the replacement pipeline. The existing pipeline will be abandoned in place. Small areas of excavation will be necessary to purge and cut and cap the abandoned pipeline. Additional technical features of the project are described below:

***Pipeline MAOP:*** The new pipeline will operate at an MAOP of 249 pounds per square inch (“psi”).

***Pipe Material:*** The replacement pipeline is 12-inches in diameter with a wall thickness of 0.375 inch and a yield strength of 42,000 psi and 16-inches with a wall thickness of 0.375 inch and a yield strength of 42,000 psi. It will be cathodically protected with 17-pound anodes and externally coated with 14-16 mils of fusion bonded epoxy or powercrete epoxy.

***Structures:*** No additional structures will be required for the new pipeline.

***Right-of-Way (“ROW”) and/or Land Requirement:*** The project is located within public ROW, existing DEO easements and new acquired DEO easement. The temporary construction materials laydown areas will be necessary to store and stage material and will be determined after the bid has been awarded to the contractor.

**4906-6-05(B)(9)(c): Estimated Capital Costs**

The capital cost of the project is estimated to be approximately \$1,200,000.

**4906-6-05(B)(10)(a): Land Use**

Land use within the Project Area is primarily rural residential properties consisting of existing off-road easement, maintained lawn, agricultural field, and other open fields with low-growing shrubbery. Per the initial environmental Field Summary Report prepared by Environmental Consulting & Technology, Inc (“ECT”), which reviewed all areas

**CASE NO. 24-0166-GA-BNR**  
**CONSTRUCTION NOTICE FOR**  
**PIR 2788 – APPLE CREEK (2024) PIPELINE REPLACEMENT PROJECT**

approximately 30 to 50 feet from the pipeline centerline and/or 20 to 40 feet from the edge of pavement, the Project Area contains wetlands and streams, (**Attachment D**).

**4906-6-05(B)(10)(b): Agricultural Land**

The vegetative communities within the Project Area include mature woods, active agricultural fields, and emergent and forested wetland areas. Per the Wayne County auditor website, three properties within the Project Area are zoned for agricultural use (parcel numbers 56-02049.000, 56-02263.000, and 56-02263.002). Existing and new pipeline within these fields will be replaced or installed with no change in post construction land cover or use; therefore, the project will not have an impact on agricultural activities.

**4906-6-05(B)(10)(c): Archeological and Cultural Resources**

In February 2024, DEO’s consultant, ECT performed an Ohio Historic Preservation Office (“OHPO”) Desktop Review for archaeological and cultural resources within the Project Area and 1-mile buffer surrounding the Project Area (**Attachment E**).

The desktop review included a search for records of Ohio Archaeological Inventory (“OAI”) locations, Ohio Historic Inventory (“OHI”) Properties, National Register Listed Properties, National Register Listed Districts, Determinations of Eligibility, Phase 1, 2, or 3 Survey Areas, and local historic districts and properties.

ECT’s review of data provided by the OHPO identified four previously completed Phase I archaeological surveys and one Phase II archaeological site evaluation within one mile of the Project Area. A previous Phase 2 Archaeological Survey was conducted immediately south of the PIR 2788 study area for the proposed Route U.S. 30 widening

**CASE NO. 24-0166-GA-BNR**  
**CONSTRUCTION NOTICE FOR**  
**PIR 2788 – APPLE CREEK (2024) PIPELINE REPLACEMENT PROJECT**

corridor from November 1993 until July 1994. A total of 297 Archaeological Sites were identified during the survey, but none of these are located within or adjacent to the Project Area.

ECT identified 13 previously recorded above ground resources within one mile of the Project Area. These resources consist of mostly single dwellings constructed between 1820 and 1960 but also include commercial and agricultural properties. No NRHP determinations were included in the spatial data provided by the OHPO for any of the above ground historic resources.

A total of 46 previously recorded archaeological sites were identified within one mile of the Project Area. One OAI Site, the Taggart Farm Site (WE0085), overlaps the northeastern Project Area. The exact location of the site is unknown, and the site boundary as shown on the attached mapping is approximated by the OHPO.

ECT completed a Phase I Archaeological Survey of the Taggart Farm Site in late January and Early February 2024 (Attachment E). The Survey Area extended across approximately 2.27 acres consisting of open agricultural field and forested wetlands along the north bank of Apple Creek. The investigation resulted in the recovery of four (4) artifacts and one possible cultural feature. Given the low density of artifacts and extent of negative shovel testing, the only portion of the Taggart Farm Site within the Project Area that retains the potential to contain significant information is the possible cultural feature. DEO has elected to avoid impacts to the potential feature. Temporary construction fencing and or timber mats will be installed and centered around the site. The avoidance buffer will extend 10 m (32.8 ft) to the east and west of the between the existing pipeline trench and the southern boundary of the Project limits of disturbance.

**CASE NO. 24-0166-GA-BNR  
CONSTRUCTION NOTICE FOR  
PIR 2788 – APPLE CREEK (2024) PIPELINE REPLACEMENT PROJECT**

On February 21, 2024, DEO initiated Section 106 consultation with the OHPO to confirm that the Project will have no adverse effects on the Taggart Farm Site, the identified cultural resource, or other cultural or historical resources (Attachment E).

Response from the OHPO is pending.

**4906-6-05(B)(10)(d): List of Governmental Agencies Which Have Requirements to Be Met by the Project**

The following agencies have requirements to be met at various times by this project:

Name of Agency	Document to be Submitted or Prepared	Attachment
	Field Summary Report	D
Ohio Historic Preservation Office	Phase I Archaeological Survey Report	E
	Section 106 Project Review Application Submittal	
	Stormwater Pollution Prevention Plan	F
Wayne County Soil and Water Conservation District (“SWCD”) and Planning Department	SWPPP and Floodplain Coordination	G
Ohio Environmental Protection Agency (“EPA”) National Pollutant Discharge Elimination System (“NPDES”) Program	NOI for General Construction Stormwater Permit Application	H
U.S. Fish and Wildlife Service (“USFWS”)	January 25, 2022, Bald Eagle Email Coordination	I
	January 23, 2024, Information for Planning and Consultation Online Review and Coordination	J
	January 26, 2024, USFWS Response	K
Ohio Department of Natural Resources (“ODNR”)	January 29, 2024, Threatened and Endangered Species Coordination Submittal	L

**Submitted by**  
**The East Ohio Gas Company d/b/a Dominion Energy Ohio**

Project #P40080793 MWO#64036806

**CASE NO. 24-0166-GA-BNR**  
**CONSTRUCTION NOTICE FOR**  
**PIR 2788 – APPLE CREEK (2024) PIPELINE REPLACEMENT PROJECT**

U.S. Army Corps of Engineers ("USACE")	Nationwide Permit 12 Pre- Construction Notification	M
---	--	---

A construction Storm Water Pollution Prevention Plan ("SWPPP") has been prepared for the project. A copy of the SWPPP is attached as **Attachment F**. The SWPPP was submitted to Wayne County Soil and Water Conservation District on February 26, 2024 (**Attachment G**) and will be included in the package submitted for competitive bids from contractors.

A NOI was submitted to the Ohio EPA for the project on February 26, 2024 (**Attachment H**).

The project is located within the Federal Emergency Management Agency 1% annual chance floodplain or regulatory floodway associated with Apple Creek. A request for a floodplain development permit from Wayne County Planning Department was submitted as a single coordination packet with the SWPPP review request on February 26, 2024 (**Attachment G**). The floodplain permit is pending.

The discharge method and location for hydrostatic test waters will be determined when the construction contract is awarded, or during the pre-construction meeting. A permit is not required if test waters will not enter any wetlands, streams, or other water bodies. Should hydrostatic test waters be discharged into waters of the State, a Hydrostatic Test Water Discharge Notice of Intent under the current available permit from Ohio Environmental Protection Agency will be obtained prior to hydrostatic testing.

**4906-6-05(B)(10)(e): Federal and State Designated Species**

**CASE NO. 24-0166-GA-BNR**  
**CONSTRUCTION NOTICE FOR**  
**PIR 2788 – APPLE CREEK (2024) PIPELINE REPLACEMENT PROJECT**

On May 13 and November 18, 2020, March 4 and April 30, 2021, and July 8, 2022, DEO’s consultant, ECT, reviewed the study area for suitable habitat for federally listed species known to be located within Wayne County, Ohio. The results are included in the Field Summary Report provided in **Attachment D**.

On January 23, 2024, ECT requested an official species list from the U.S. Fish and Wildlife Service (“USFWS”) through the USFWS Information for Planning and Consultation (“IPaC”) system. The species list produced from USFWS indicates that five (5) federally listed species have ranges which include Wayne County, Ohio: the federally endangered Indiana bat (*Myotis sodalis*), the federally endangered northern long-eared bat (*Myotis septentrionalis*), and the federally threatened eastern prairie fringed orchid (*Platanthera leucophaea*). Additionally, the monarch butterfly (*Danaus plexippus*) is designated as a federal candidate species and the tricolored bat (*Perimyotis subflavus*) is indicated as proposed endangered. Additionally, the response indicated that there are responsibilities under the Migratory Bird Treaty Act and the Bald and Golden Eagle Protection Act to protect native birds from project-related activities. Any activities, intentional or unintentional, resulting in take of migratory birds, including eagles, is prohibited unless otherwise permitted by USFWS. Lastly, the IPaC indicated there are no critical habitats within the Project Area under the office’s jurisdiction.

The ECT field review of the Project Area indicated 11 potential roost trees (“PRTs”) with potential summer roosting habitat for the listed bats (Attachment D). No trees suitable for maternity roosts were identified within the study area. All tree clearing for the Project will be conducted during the USFWS winter tree clearing window (October 1 through March 31) to avoid impacts to federally listed bats.



**CASE NO. 24-0166-GA-BNR**  
**CONSTRUCTION NOTICE FOR**  
**PIR 2788 – APPLE CREEK (2024) PIPELINE REPLACEMENT PROJECT**

The bald eagle (*Haliaeetus leucocephalus*) nests in large trees near water. No bald eagles or bald eagle nesting sites were observed within or adjacent to the study area. Wooster Township in Wayne County has no known bald eagle nesting sites per information provided by USFWS in 2022. An email was sent on January 12, 2022, to USFWS requesting proximity of the closest bald eagle nest to the project. A response from USFWS was received on January 25, 2023, indicating that no known bald eagle nest records are located within 0.5-mile of the Project Area (**Attachment I**).

On January 23, 2024, an email was sent to USFWS requesting review of the project with regard to the Endangered Species Act (**Attachment J**). On January 26, 2024, USFWS responded that due to the project type, size, location and the proposed implementation of seasonal tree clearing (clearing trees  $\geq 3$  inches diameter at breast height [“DBH”] between October 1 and March 31) to avoid impacts to the endangered Indiana bat, northern long-eared bat, and the proposed endangered tricolored bat, that USFWS does not anticipate adverse effects to these species or any other federally endangered, threatened, or proposed species, or proposed or designated critical habitat. A copy of the response is in **Attachment K**.

DEO submitted a letter on January 29, 2024, to the Ohio Department of Natural Resources (“ODNR”) requesting a finding from ODNR regarding any adverse effect to any state listed and natural areas that have a geological and/or ecological significance to them (**Attachment L**). A response from ODNR is pending.

**4906-6-05(B)(10)(f): Areas of Ecological Concern**

**CASE NO. 24-0166-GA-BNR**  
**CONSTRUCTION NOTICE FOR**  
**PIR 2788 – APPLE CREEK (2024) PIPELINE REPLACEMENT PROJECT**

There are no national or state parks or forests, national or state wild and scenic rivers, designated or proposed wilderness areas, wildlife refuges, wildlife management areas, or wildlife sanctuaries located in the immediate vicinity of the proposed project.

According to ECT's assessment of the Project Area, one wetland and six streams are located within the Project Area.

One (1) wetland and five (5) streams will be temporarily impacted by construction activities associated with the installation of the pipeline, as such, a request for Nationwide Permit, Number 12 was submitted on January 26, 2024 (**Attachment M**). Authorization from the United States Army Corps of Engineers is pending. Construction will be limited will require soil disturbance to accommodate areas for trench excavation, side-cast spoil, temporary storage of the new pipe, and equipment/vehicular traffic.

Separation of the topsoil from the subsoil will generally be performed within wetlands, streams, at the residential and agricultural properties. The backfill material that will be returned to the trench will consist of the same material removed from the excavation to the extent practicable.

Following pipeline replacement, all disturbed areas will be returned to their original slope and contour, stabilized, seeded, and revegetated to provide a permanent herbaceous cover to stabilize the soils, and temporary erosion controls will be maintained until this permanent cover is established.

**4906-6-05(B)(10)(g): Any Known Unusual Conditions Resulting in Significant Environmental, Social, Health, or Safety Impacts**

DEO conducted a review of the Ohio Department of Transportation's Ohio Regulate Properties Search (ORPS) tool to assess for readily known unusual conditions in

**CASE NO. 24-0166-GA-BNR  
CONSTRUCTION NOTICE FOR  
PIR 2788 – APPLE CREEK (2024) PIPELINE REPLACEMENT PROJECT**

the Project Area and surrounding area that could result in significant environmental impacts. Six inactive underground storage tanks (USTs) were located at 326 N Hillcrest Drive but were removed in April 1992. As illustrated by the studies and investigations conducted as a part of this project to date (refer to the Attachments), there are no readily known unusual conditions in the area of the proposed project that will result in significant environmental impacts. Other than potential health and safety issues associated with construction, which will be minimized with the best practices during construction, there are no additional health, social or safety impacts that will exist as a result of this project.

**4906-6-07 SERVICE AND PUBLIC DISTRIBUTION OF ACCELERATED  
CERTIFICATE APPLICATIONS**

**4906-6-07(A)(1): Service of Accelerated Application upon Officials**

Simultaneously with the filing this accelerated application with the Board, DEO is also delivering the application to the following public officials:

Steve Miller  
Wooster Twp Trustee President  
838 Heyl Rd  
Wooster, OH 44691

Mike Lindeman  
Wooster Twp Trustee  
838 Heyl Rd  
Wooster, OH 44691

Wayne Soil & Water  
Conservation District  
428 W Liberty St  
Wooster, OH 44691

Matt Ogden  
Wooster Twp Trustee  
838 Heyl Rd  
Wooster, OH 44691

A copy of the transmittal letter, **Attachment N**, has been sent to the officials listed above.

**CASE NO. 24-0166-GA-BNR**  
**CONSTRUCTION NOTICE FOR**  
**PIR 2788 – APPLE CREEK (2024) PIPELINE REPLACEMENT PROJECT**

**4906-6-07(A)(2): Service of Accelerated Application upon Main Public Libraries of Each Political Subdivision**

A copy of this accelerated application is being sent to the main branch of the Wayne County Public Library located at 220 W Liberty St, Wooster, OH 44691.

**4906-6-07(A)(3): DEO's Website**

A copy of the application is located on DEO's web page at <https://www.dominionenergy.com/siting%20board>. Choose the case number of this case to access.

Further interested persons may contact DEO at 320 Springside Dr., Akron, Ohio 44333 to obtain either an electronic copy or a paper copy of this accelerated application.

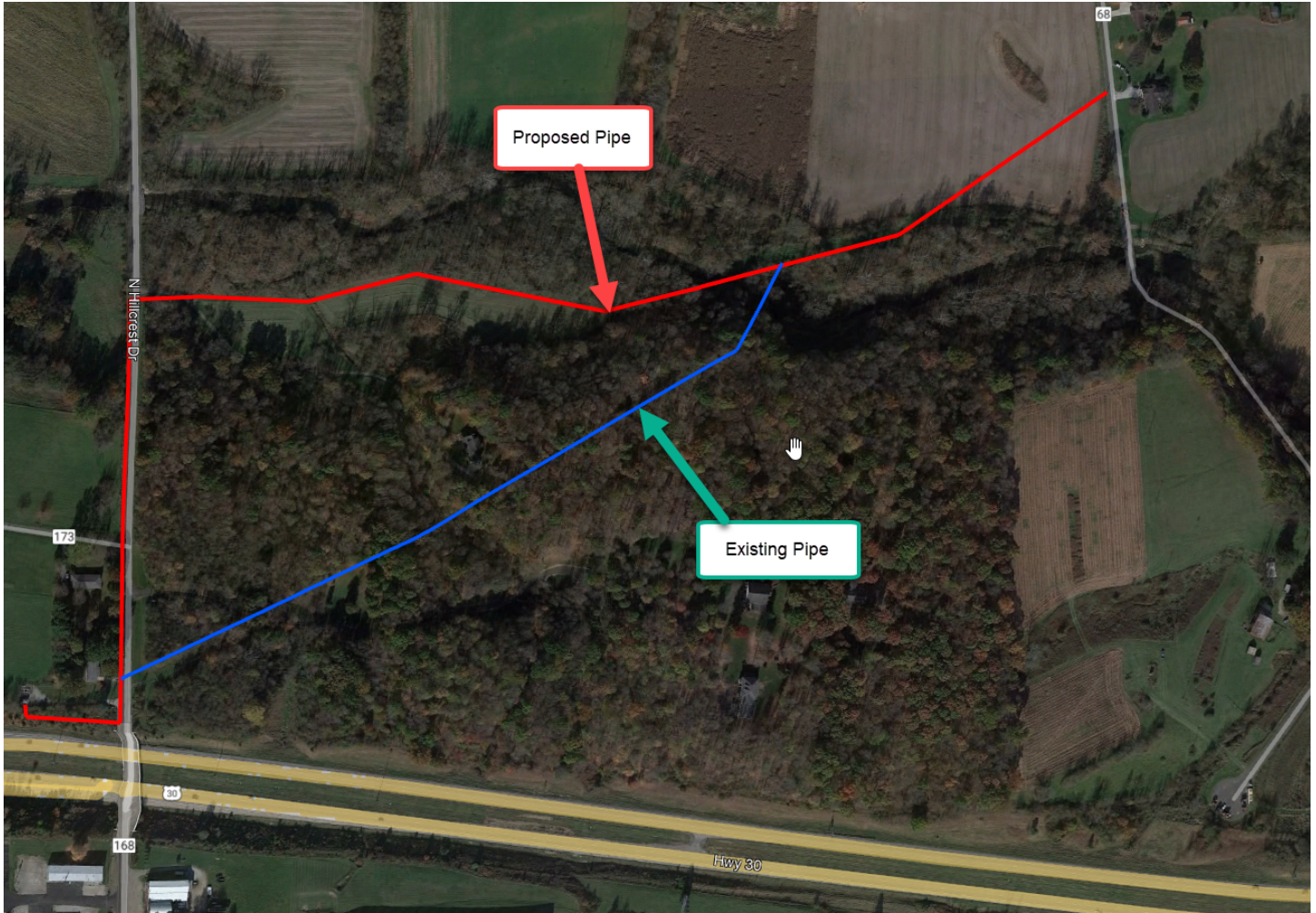
**4906-6-07(B): Proof of Compliance**

Within seven (7) days of the filing of this accelerated application, DEO will file proof of compliance with Rule 4906-6-07.

**CASE NO. 24-0166-GA-BNR  
CONSTRUCTION NOTICE FOR  
PIR 2788 – APPLE CREEK (2024) PIPELINE REPLACEMENT PROJECT**

**ATTACHMENT A**

**AERIAL MAP**





## ATTACHMENT B

### LANDOWNERS OF PERMANENT & TEMPORARY EASEMENTS

Current Property Owner	Property Address	City	State	Zip	City	State	Zip	Parcel #
Larry W Beckler	3671 Canal Rd	Wooster	OH	44691				56-01847.000
Donald Chester & Mary Josephine Beckler	615 N Geyers Chapel Rd	Wooster	OH	44691				56-01848.000
Gary & Linda Beckler	699 N Geyers Chapel Rd	Wooster	OH	44691				56-01849.000
Bonnie Kay Edwards, Trustee	Canal Rd	Wooster	OH	44691	Wooster	OH	44691	56-01846.000
<b>Geyers Chapel Rd</b>								
JRB Holding LLC	Canal Rd	Wooster	OH	44691	Wooster	OH	44691	56-05563.002
Bedrock Landscaping Inc	3399 Canal Rd	Wooster	OH	44691	Wooster	OH	44691	56-05563.004
Double K Farm LTD	3295 Canal Rd	Wooster	OH	44691	Wooster	OH	44691	56-02264.000 56-01947.000
Gregory & Karen M Cantrell, Co-Trustees	3051 Canal Rd	Wooster	OH	44691				56-05563.002
<b>Apple Creek</b>								
James M Bowling, Trustee jimmerbowling@gmail.com	555 N Hillcrest Dr	Wooster	OH	44691				56-05563.003
Mary E McCoy, Trustee John McCoy (Son)	707 N Hillcrest Dr	Woosteer	OH	44691				56-02263.000
<b>Hillcrest Rd</b>								
John & Rhonda Bowling	555 N Hillcrest Dr	Wooster	OH	44691	Wooster	OH	44691	56-02263.009 56-02263.010 56-02263.011
John R. Bowling	551 N Hillcrest Dr	Wooster	OH	44691				56-02263.008
Tracy J & Kim Mong	2967 Varian Rd	Wooster	OH	44691				56-01407.000
Robert W & Laura L Wirth	538 Hillcrest Rd	Wooster	OH	44691				56-01075.000 56-01075.001
Tucker V & Payton N Wirth	2909 Varian Rd	Wooster	OH	44691				56-02049.001

## ATTACHMENT C

[DATE]

ADDRESS

**Re: PIR 2788 Apple Creek  
Ohio Power Siting Board, Case # 24-0166-GA-BNR**

Dear [**Property Owner or Tenant**]:

The Ohio Power Siting Board (OPSB) has approved Dominion Energy Ohio's (DEO) application to construct the above-referenced project. This letter summarizes important information about the project schedule and contact information during the construction process.

### **Nature of the Project**

This project involves [**same description as application**]. Complete project details may be found on the OPSB's website ([www.opsb.ohio.gov](http://www.opsb.ohio.gov)) and DEO's corporate website ([www.dominionenergy.com/siting](http://www.dominionenergy.com/siting) board) by referencing case number [**insert**].

### **Construction schedule**

DEO plans to commence construction on approximately [**date**] and conclude the project by [**approx. date**]. To the extent the project involves construction on your property, DEO will restore your property as close as possible to its original condition prior to construction. Restoration will commence following project completion, including sidewalks, driveways, and grading and reseeding yards. DEO expects that restoration activities will be completed by [**date**]. The exact dates for project start and completion are subject to weather conditions or other factors beyond the company's control.

### **Contact information and dispute resolution**

Please contact DEO's Land Services Department at 1-855-226-6022 with any questions or concerns that arise during the course of the project. You may be asked to provide the Project Reference Number at the bottom of this letter. A dedicated Land Services Agent will be assigned to work with you and the Project Manager to resolve your questions or concerns. Please note that due to the nature of work in the field, a representative from DEO will return your telephone call as soon as possible. Emergencies should be reported to your local police or fire department, or 9-1-1.

We thank you in advance for your patience and cooperation during this project.

Sincerely,

DOMINION ENERGY OHIO

Land Services Department

**ATTACHMENT D**  
**ENVIROSCIENCE'S FIELD SUMMARY REPORT**



November 11, 2020  
ECT No.200336

Jonathon Blackwell  
Dominion Energy Ohio  
320 Springside Drive, Suite 320  
Akron, Ohio 44333

Re: *Field Summary Report* – PIR 2788 – Apple Creek, Wooster Township, Wayne County, Ohio

Dear Mr. Blackwell.:

The East Ohio Gas Company, d/b/a Dominion Energy Ohio, contracted Environmental Consulting & Technology, Inc. (ECT), to perform an ecological study for the PIR 2788 – Apple Creek project (Project) located in Wooster Township, Wayne County, Ohio. The study included review of the Project for surface waters (e.g., wetlands, streams, ponds), potential habitat for endangered and threatened species (TES), and existing cultural and historic resources. Existing stormwater features were also identified and recorded. The area reviewed included approximately 50 feet on either side of the existing pipeline within the study area. Maps depicting the results of ecological review are provided in Attachment A. Photographs depicting the study area are provided in Attachment B.

## **SITE DESCRIPTION**

An environmental field review of the study area was completed on May 13, 2020. The study area is dominated by undeveloped, agricultural, and rural residential areas. The study area primarily has land cover of mature woods, active agricultural fields, and emergent and forested wetland areas.

## **WETLANDS AND WATERWAYS DELINEATION**

### **Wetlands**

Wetland A is located within central portions of the study area with the floodplain of Apple Creek. An Ohio Rapid Assessment Method (ORAM), Version 5.0, form was completed to evaluate wetland quality. ORAM measures several metrics including wetland hydrology, size, and habitat alteration. Each metric is scored and then totaled to give a final ORAM score corresponding to an ORAM category (1 through 3). Category 1 wetlands represent low quality wetlands while Category 3 wetlands are high quality wetlands.

Table 1. Wetlands Identified within PIR 2788

Wetland ID	ORAM Score	ORAM Category	PEM <sup>1</sup> within Study Area (acres)	PSS <sup>2</sup> within Study Area (acres)	PFO <sup>3</sup> within Study Area (acres)	Total Acreage within Study Area
A	40	Mod. 2	0.701	0.00	0.200	<b>0.901</b>

Source: ECT 2020

<sup>1</sup> Palustrine emergent

<sup>2</sup> Palustrine scrub-shrub

<sup>3</sup> Palustrine forested

Wetland A is located within the floodplain on the north side of Stream 1 (Apple Creek) and is composed of emergent and forested vegetation communities. Emergent areas within Wetland A are dominated by the invasive species reed canary grass (*Phalaris arundinacea*) and by bristly buttercup (*Ranunculus hispidus*). Common tree species within the forested portions of Wetland A include Ohio buckeye (*Aeculus glabra*), black cherry (*Prunus serotina*), and sycamore (*Platanus occidentalis*). The northern boundary of Wetland A also runs along the edge of active row cropping. Previous and current disturbances to Wetland A include mowing, farming, clearcutting, and nutrient enrichment. Wetland A received a score of 40 on the ORAM, placing it within the modified Category 2.

### Waterways

Two (2) streams are located within the study area. Stream 1 (Apple Creek) is a large perennial stream that flows east to west across the study area. Stream 2 is a small ephemeral stream located in the northeastern extent of the study area along Geyers Chapel Road and flows north to south. Stream quality assessments were conducted following the Ohio Environmental Protection Agency's (OEPA) Qualitative Habitat Evaluation Index (QHEI) and Headwater Habitat Evaluation Index (HHE) dependent upon stream size and/or maximum pool depth. Stream 1 has a watershed  $\geq 1$  square mile and a maximum pool depth  $\geq 40$  centimeters and was therefore assessed following the QHEI. Stream 2 has a watershed  $< 1$  square mile and a maximum pool depth of  $< 40$  centimeters and was therefore assessed using the HHEI. Both methodologies assess several stream metrics, such as substrate type, and assigns scores for each metric. Totaled scores are used to determine the general quality of streams.

Stream 1 (Apple Creek) is a large (34 square mile drainage area) perennial stream that flows east to west across the study area. Dominant substrate types within Stream 1 include cobble and gravel. Although the assessed reach of Stream 1 is protected within a forested riparian area, the surrounding agricultural landscape likely influences sedimentation and nutrient loads within the stream. Stream 1 (Apple Creek) received a score of 69 on the QHEI, indicating it has potential to attain Warmwater Habitat. Apple Creek has been designated as Warmwater Habitat by the OEPA.

Stream 2, an ephemeral stream, drains south through the study area along the western side of Geyers Chapel Road. At the time of the stream assessment, no water was observed within Stream 2, but a defined bed and bank were observed. Substrates of Stream 2 are dominated by silt and clay/hardpan. The stream has been channelized to run parallel to the road, and water quality is likely heavily influenced by stormwater from the adjacent roadway and agricultural fields. Stream 2 received a score of 13 on the HHEI, classifying it as a Modified Ephemeral Stream.

Table 2. Streams Identified within PIR 2788

Stream ID	Flow Regime	Bankfull Width (ft)	Length (lf) within Study Area	Dominant Substrate Types	QHEI* / HHEI Score	Class / Designation
1 (Apple Creek)	Perennial	48	100	Cobble, gravel	69*	Warmwater Habitat
2	Ephemeral	2	107	Silt, clay/hardpan	13	Modified Ephemeral Stream
<b>Total (lf)</b>						<b>249</b>

Source: ECT 2020

## THREATENED AND ENDANGERED SPECIES EVALUATION

A search of the U.S. Fish and Wildlife Service (USFWS) Information for Planning and Consultation (IPaC) system was completed to identify potential for federally listed species to occur in the study area. The following four (4) species were identified by the IPaC search:

### Bats

USFWS results indicated that the federally endangered Indiana bat (*Myotis sodalis*) and the federally threatened northern long-eared bat (*Myotis septentrionalis*) may be affected by Project activities. These bat species typically summer roost within forested areas under the loose bark of dead or dying trees. During the field survey, ECT identified 10 trees within and adjacent to the study area with potential summer roosting habitat for the listed bats. No trees suitable for maternity roosts were identified within the study area. Photographs depicting potential habitat trees are included in the photographic log in Attachment B. A table providing information on potential roost trees is provided in Attachment E.

### Eastern Prairie Fringed Orchid

USFWS results indicated that the federally threatened eastern prairie fringed orchid (*Platanthera leucophaea*) may be affected by Project activities. This species prefers habitats of prairie and wetland habitat including sedge meadows and marshes. The study area is primarily composed of forested areas and disturbed land covers including active row crops, old field, and pavement. Although an area of emergent wetland is located within the study area, this is dominated by invasive species and unlikely to provide habitat for the eastern prairie fringed orchid. Further, eastern prairie fringed orchid was not identified during the site visit. It is unlikely that suitable habitat for the eastern prairie fringed orchid would be found on-site.

### Bald Eagle

The bald eagle (*Haliaeetus leucocephalus*) is protected under the Bald and Golden Eagle Protection Act. Bald eagles live near large bodies of water including estuaries, rivers, lakes, reservoirs, and coasts that provide a foraging base for the birds. Breeding eagles typically construct nests in large conifers that extend above the surrounding canopy. No bald eagles or bald eagle nests were identified during the field review. Further, the Project is located in Wooster Township in Wayne County, which has no records of bald eagle nests per information provided by USFWS.

## FLOODPLAINS

The majority of the study area is located within the Federal Emergency Management Agency 1% annual chance floodplain or regulatory floodway associated with Stream 1 (Apple Creek). The location of the floodway and floodplain are depicted on the Ecological Resources Map provided in Attachment A: Figure 5.

## CULTURAL RESOURCES

The Ohio History Connection Online Mapping System was searched to identify documented historic and cultural resources within or adjacent to the study area including National Register (NR) listed districts, NR properties, Ohio Historic Inventory structures, Ohio Genealogical Society cemeteries, Archaeological Sites, and Phase 1/2/3 Archaeological Surveys.


A Previous Phase 2 Archaeological Survey was conducted immediately south of the PIR 2788 study area for the proposed Route U.S. 30 widening corridor from November 1993 until July 1994. A total of 297 Archaeological Sites were identified during the survey, but none of these identified sites are located within or adjacent to the study area.

Additionally, one (1) previously recorded Archaeological Site, the Taggart Farm site (WE0085), most of the study area north of Stream 1 (Apple Creek) and is designated based on its historic affiliation. The exact location of the site is unknown, and the site boundary as shown in the Cultural Resources Map in Attachment A: Figure 6 is approximated by the Ohio Historic Preservation Office. The site is currently under agricultural use and has likely been disturbed by plowing.

If you have any questions or need additional information, please contact Val Locker at (216) 518-2807 ext. 21307 or [vlocker@ectinc.com](mailto:vlocker@ectinc.com).

Sincerely,

## ENVIRONMENTAL CONSULTING & TECHNOLOGY, INC.

  
Alyssa Dietz-Oergel  
Associate Scientist I

  
Val Locker  
Senior Associate Scientist

cc: Greg Eastridge Dominion Energy Services, Inc.

## **Attachment A**

### **Background and Ecological Resources Maps**

**Figure 1. Site Location Map**

**Figure 2. USGS Topographic Map**

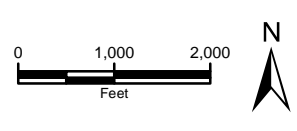
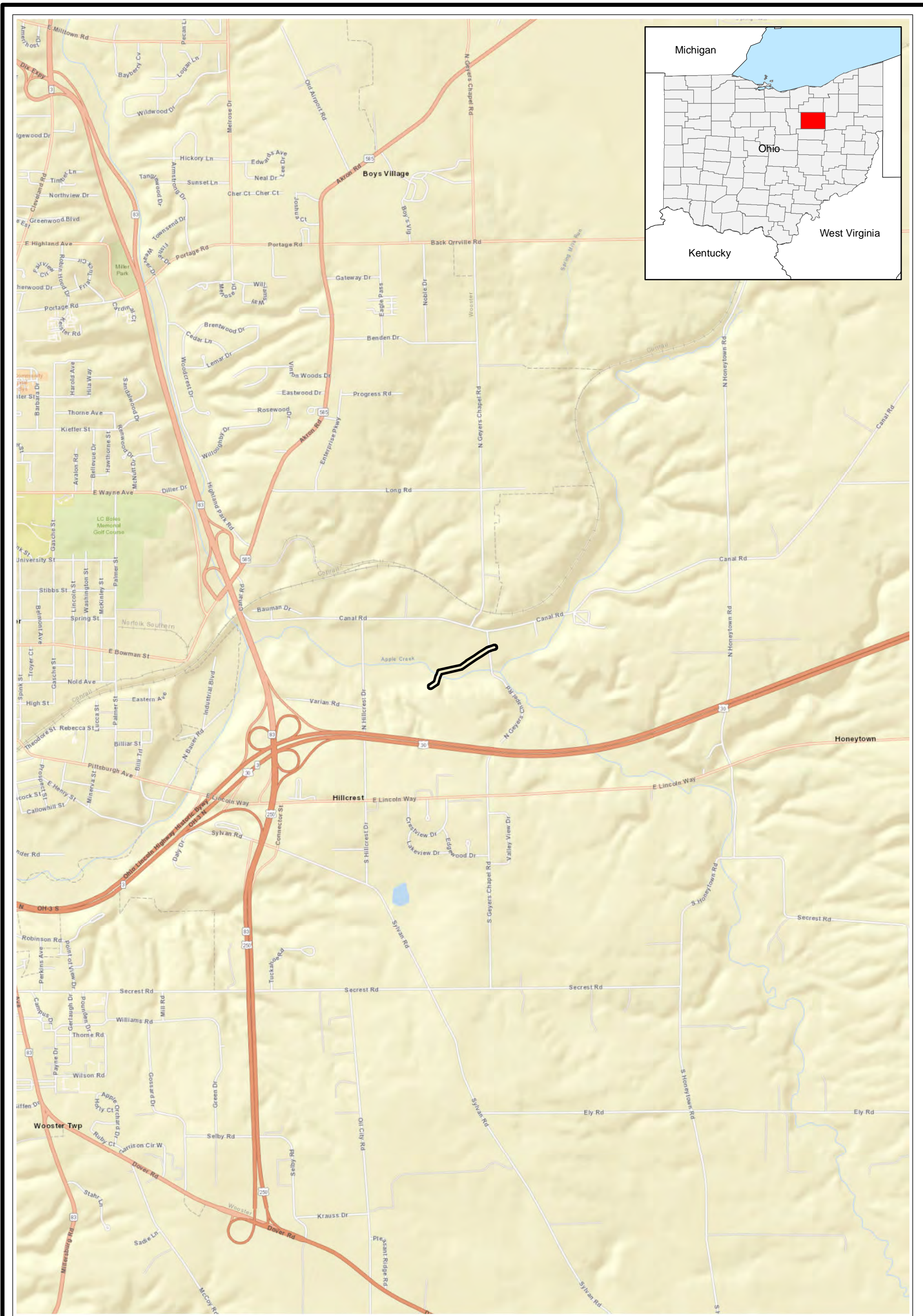
**Figure 3. NWI and NHD Features Map**

**Figure 4. NRCS Soil Survey Units Map**

**Figure 5. Ecological Resources Maps**

**Figure 6. Cultural Resources Map**





Project Area Boundary

**FIGURE 1. SITE LOCATION MAP**  
**PIR 2788 - APPLE CREEK**  
**DOMINION ENERGY OHIO**  
**WOOSTER TOWNSHIP, WAYNE COUNTY, OHIO**  
 Sources: ESRI Street Map, 2019; ECT, 2020.





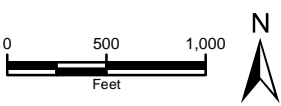
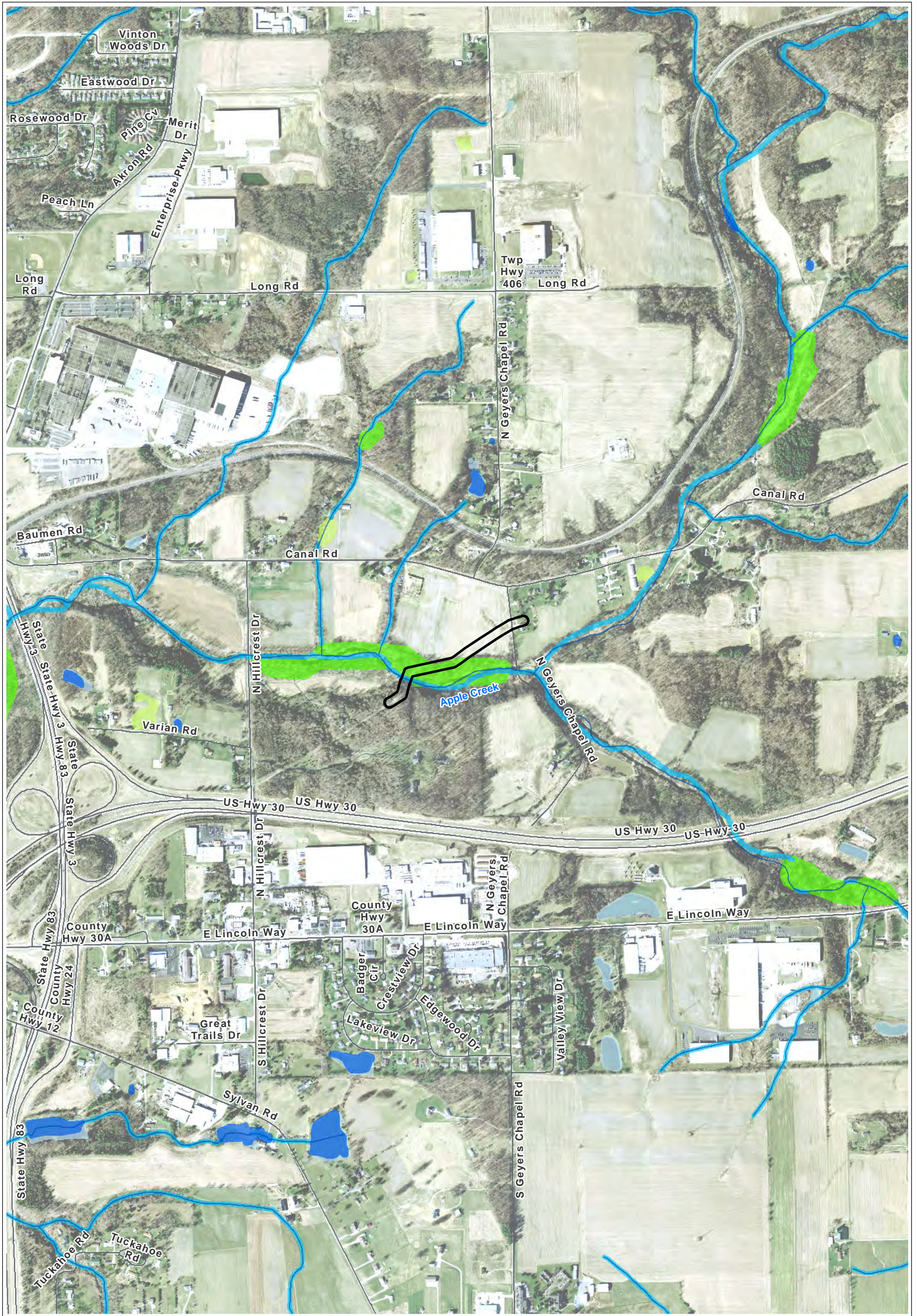


FIGURE 2. USGS TOPOGRAPHIC MAP  
 PIR 2788 - APPLE CREEK  
 DOMINION ENERGY OHIO  
 WOOSTER TOWNSHIP, WAYNE COUNTY, OHIO

Sources: US TopoMaps; ECT, 2020.







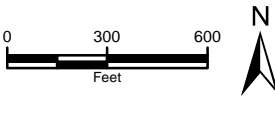
- |                       |                                   |          |
|-----------------------|-----------------------------------|----------|
| Project Area Boundary | Freshwater Emergent Wetland       | Lake     |
| NHD Flowline          | Freshwater Forested/Shrub Wetland | Other    |
| NHD Waterbody         | Freshwater Pond                   | Riverine |

FIGURE 4. NWI & NHD FEATURES MAP  
 PIR 2788 - APPLE CREEK  
 DOMINION ENERGY OHIO  
 WOOSTER TOWNSHIP, WAYNE COUNTY, OHIO

Sources: USGS, 2018; USFWS, 2020; OSIP, 2012; ECT, 2020.







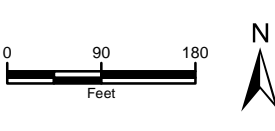
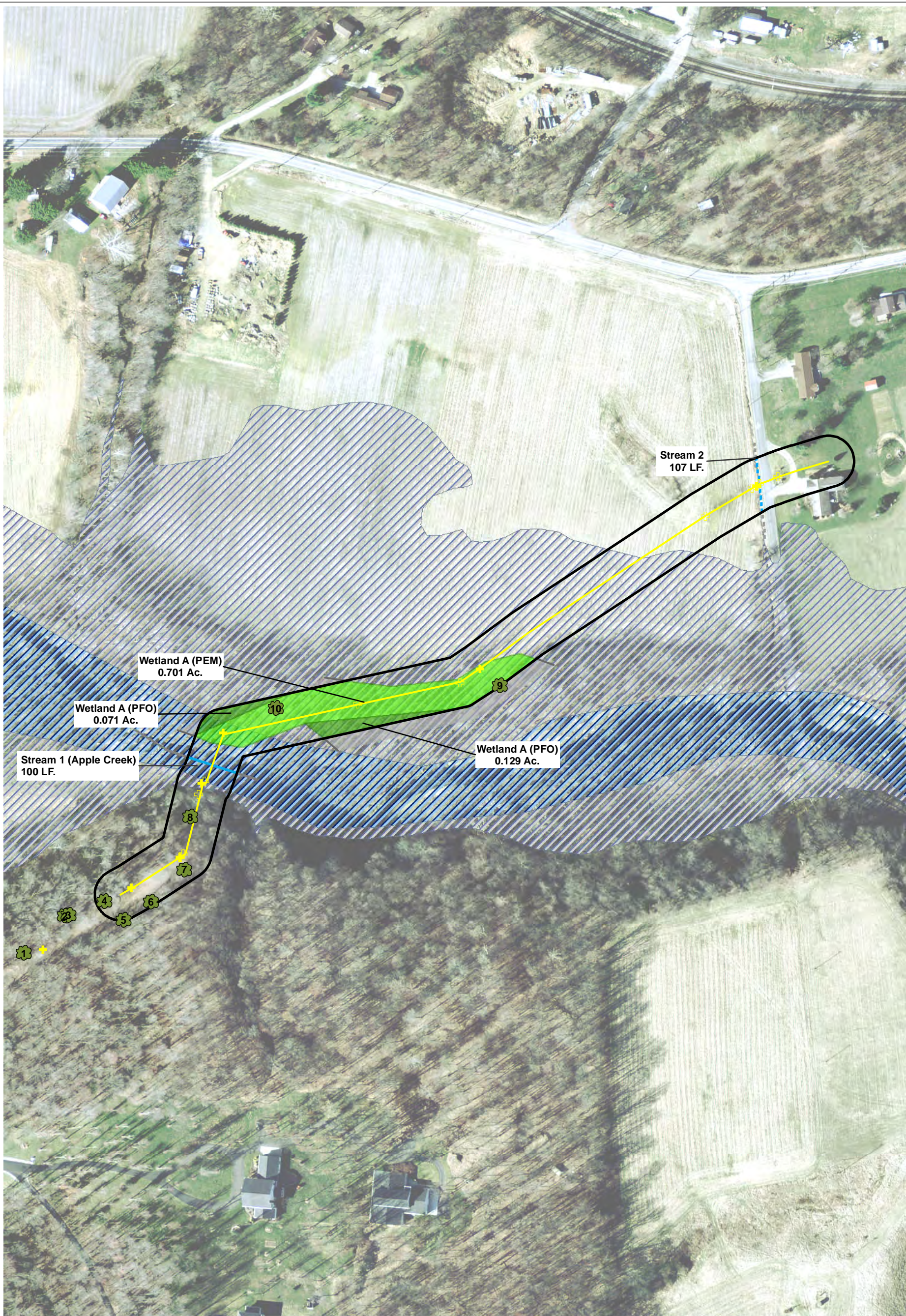
- Project Area Boundary
- Non-Hydric Soils
- Predominantly Non-Hydric Soils

FIGURE 3. NRCS SOIL SURVEY UNITS MAP  
 PIR 2788 - APPLE CREEK  
 DOMINION ENERGY OHIO  
 WOOSTER TOWNSHIP, WAYNE COUNTY, OHIO

Sources: NRCS, 2020; OSIP, 2012; ECT, 2020.







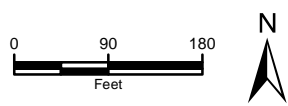
- |                          |                      |                    |                               |
|--------------------------|----------------------|--------------------|-------------------------------|
| Project Area Boundary    | On-site PEM Wetland  | On-site Perennial  | 1% Annual Chance Flood Hazard |
| Existing Gas HP Pipeline | Off-site PEM Wetland | On-site Ephemeral  | Regulatory Floodway           |
| Potential Roost Tree     | On-site PFO Wetland  | Off-site Perennial |                               |
| Perm Pipeline Marker     | Off-site PFO Wetland | Off-site Ephemeral |                               |
| Temp Pipeline Marker     |                      |                    |                               |

FIGURE 5. ECOLOGICAL RESOURCES MAP  
 PIR 2788 - APPLE CREEK  
 DOMINION ENERGY OHIO  
 WOOSTER TOWNSHIP, WAYNE COUNTY, OHIO

Sources: OSIP, 2012; ECT, 2020.







- Project Area Boundary
- Existing Gas HP Pipeline
- Phase 1 Archaeological Survey
- ▲ Archaeological Sites
- OAI Site Boundaries

FIGURE 6. HISTORICAL AND CULTURAL RESOURCES MAP  
 PIR 2788 - APPLE CREEK  
 DOMINION ENERGY OHIO  
 WOOSTER TOWNSHIP, WAYNE COUNTY, OHIO


Sources: OSIP, 2012; ECT, 2020.






**Attachment B**  
**Photographic Log**

## PHOTOGRAPHIC LOG


<b>Photo # 1</b>	
Date: 05/13/2020	
Feature: Upland easement	
Description: South of Stream 1 (Apple Creek) the study area contains upland mowed easement forested areas.	

<b>Photo # 2</b>	
Date: 05/13/2020	
Feature: Agricultural Areas	
Description: The northern study are crosses active agricultural fields.	



## PHOTOGRAPHIC LOG

<b>Photo # 3</b>	
Date: 05/13/2020	
Feature: Residential Area	
Description: The northern extent of the study area abuts a residential property along Geyers Chapel Road.	

<b>Photo # 4</b>	
Date: 05/13/2020	
Feature: Wetland A	
Description: Wetland A contains areas of both emergent and forested vegetation communities. Emergent areas are dominated by reed canary grass ( <i>Phalaris arundinacea</i> ).	




## PHOTOGRAPHIC LOG


<b>Photo # 5</b>	
Date: 05/13/2020	
Feature: Stream 1 Upstream	
Description: Stream 1 (Apple Creek) drains west through the study area. Photo faces upstream portion of Stream 1 (Apple Creek).	

<b>Photo # 6</b>	
Date: 05/13/2020	
Feature: Stream 1 Downstream	
Description: Photo faces downstream portion of Stream 1 (Apple Creek).	




## PHOTOGRAPHIC LOG


<b>Photo # 7</b>	
Date: 05/13/2020	
Feature: Stream 1 Substrate	
Description: Substrates of Stream 1 (Apple Creek) are dominated by cobble and gravel.	

<b>Photo # 8</b>	
Date: 05/13/2020	
Feature: Stream 2 Upstream	
Description: Stream 2 flows north to south through the northeastern extent of the study area and is channelized along Geyers Chapel Road. Photo faces upstream portion of Stream 2.	




## PHOTOGRAPHIC LOG


<b>Photo # 9</b>	
Date: 05/13/2020	
Feature: Stream 2 Downstream	
Description: Photo faces downstream portion of Stream 2.	

<b>Photo # 10</b>	
Date: 05/13/2020	
Feature: Stream 2 Substrate	
Description: Substrates of Stream 2 are dominated by silt and clay/hardpan.	





## PHOTOGRAPHIC LOG

<b>Photo # 11</b>	
Date: 05/13/2020	
Feature: Tree 1	
Description: <i>Prunus serotina</i>	

<b>Photo # 12</b>	
Date: 05/13/2020	
Feature: Tree 2	
Description: <i>Carya ovata</i>	


## PHOTOGRAPHIC LOG

<b>Photo # 13</b>	
Date: 05/13/2020	
Feature: Tree 3	
Description: <i>Tilia americana</i>	

<b>Photo # 14</b>	
Date: 05/13/2020	
Feature: Tree 4	
Description: <i>Tilia americana</i>	





## PHOTOGRAPHIC LOG

<b>Photo # 15</b>	
Date: 05/13/2020	
Feature: Tree 5	
Description: <i>Fraxinus</i> sp.	

<b>Photo # 16</b>	
Date: 05/13/2020	
Feature: Tree 6	
Description: <i>Platanus occidentalis</i>	


## PHOTOGRAPHIC LOG

<b>Photo # 17</b>	
Date: 05/13/2020	
Feature: Tree 7	
Description: <i>Tilia americana</i>	

<b>Photo # 18</b>	
Date: 05/13/2020	
Feature: Tree 8	
Description: <i>Acer rubrum</i>	




## PHOTOGRAPHIC LOG

<b>Photo # 19</b>	
Date: 05/13/2020	
Feature: Tree 9	
Description: <i>Acer rubrum</i>	

<b>Photo # 20</b>	
Date: 05/13/2020	
Feature: Tree 10	
Description: <i>Acer negundo</i>	

## PHOTOGRAPHIC LOG

<b>Photo # 21</b>	
Date: 05/13/2020	
Feature: Archaeological Site	
Description: One previously identified archaeological site overlaps the northern study area. This site is currently under active row crop.	

**Attachment C**  
**ORAM Data Forms**



<b>Site:</b> PIR 2788-Apple Creek, Wooster Twp, Wayne County			<b>Date:</b> 21-May-20		
<b>Wetlands:</b> A			<b>Rater:</b> A. Dietz-Oergel, K. Simon		
<b>Wetland Acreage:</b>	<b>0.8+</b>	<b>ORAM Score:</b>	<b>40</b>	<b>ORAM Category:</b>	<b>Modified 2</b>

<b>3</b>	<b>3</b>
Subtotal	Points

**Metric 1. Wetland Area (size). (max 6 pts)**

Select one size class and assign score.

- >50 acres (>20.2ha) (6 pts)
- 25 to <50 acres (10.1 to <20.2ha) (5 pts)
- 10 to <25 acres (4 to <10.1ha) (4 pts)
- 3 to <10 acres (1.2 to <4ha) (3 pts)
- 0.3 to <3 acres (0.12 to <1.2ha) (2pts)
- 0.1 to <0.3 acres (0.04 to <0.12ha) (1 pt)
- <0.1 acres (0.04ha) (0 pts)

<b>11</b>	<b>8</b>
Subtotal	Points

**Metric 2. Upland buffers and surrounding land use. (max 14 pts)**

2a. Calculate average buffer width (select one, do not double check)

- WIDE. Buffers average 50m (164ft) or more around wetland perimeter (7)
- MEDIUM. Buffers average 25m to <50m (82 to <164ft) around wetland perimeter (4)
- NARROW. Buffers average 10m to <25m (32ft to <82ft) around wetland perimeter (1)
- VERY NARROW. Buffers average <10m (<32ft) around wetland perimeter (0)

2b. Intensity of surrounding land use (select one or double check & average)

- VERY LOW. 2nd growth or older forest, prairie, savannah, wildlife area, etc. (7)
- LOW. Old field (>10 years), shrubland, young second growth forest. (5)
- MODERATELY HIGH. Residential, fenced pasture, park, conservation tillage, new fallow field. (3)
- HIGH. Urban, industrial, open pasture, row cropping, mining, construction. (1)

<b>27</b>	<b>16</b>
Subtotal	Points

**Metric 3. Hydrology. (max 30 pts)**

3a. Sources of Water. Score all that apply.

- High pH groundwater (5)
- Other groundwater (3)
- Precipitation (1)
- Seasonal/Intermittent surface water (3)
- Perennial surface water (lake or stream) (5)

3d. Duration inundation/saturation.

(select one or double check & average)

- Semi- to permanently inundated/saturated (4)
- Regularly inundated/saturated (3)
- Seasonally inundated (2)
- Seasonally saturated in upper 30cm (12in) (1)

3b. Connectivity. Score all that apply.

- 100 year floodplain (1)
- Between stream/lake and other human use (1)
- Part of wetland/upland (e.g. forest), complex (1)
- Part of riparian or upland corridor (1)

3e. Modifications to natural hydrologic regime.

(select one or double check & average)

- None or none apparent (12)
- Recovered (7)
- Recovering (3)
- Recent or no recovery (1)

3c. Maximum water depth. Select only 1.

- >0.7 (27.6in) (3)
- 0.4 to 0.7m (15.7 to 27.6in) (2)
- <0.4m (<15.7in) (1)

Check all disturbances observed	
<input type="checkbox"/> ditch	<input checked="" type="checkbox"/> point source (nonstormwater)
<input type="checkbox"/> dike	<input checked="" type="checkbox"/> filling/grading
<input checked="" type="checkbox"/> tile	<input type="checkbox"/> road bed/RR track
<input type="checkbox"/> weir	<input type="checkbox"/> dredging
<input type="checkbox"/> stormwater input	<input type="checkbox"/> other- list

<b>37</b>	<b>10</b>
Subtotal	Points

**Metric 4. Habitat Alteration and Development. (max 20 pts.)**

4a. Substrate disturbance. Score one or double check and average.

- None or none apparent (4)
- Recovered (3)
- Recovering (2)
- Recent or no recovery (1)

4c. Habitat alteration. Score one or double check and average.

- None or none apparent (9)
- Recovered (6)
- Recovering (3)
- Recent or no recovery (1)

4b. Habitat development. Select one.

- Excellent (7)
- Very good (6)
- Good (5)
- Moderately good (4)
- Fair (3)
- Poor to fair (2)
- Poor (1)

Check all disturbances observed	
<input checked="" type="checkbox"/> mowing	<input checked="" type="checkbox"/> shrub/sapling removal
<input type="checkbox"/> grazing	<input type="checkbox"/> herbaceous/aquatic bed removal
<input checked="" type="checkbox"/> clearcutting	<input type="checkbox"/> sedimentation
<input checked="" type="checkbox"/> selective cutting	<input type="checkbox"/> dredging
<input checked="" type="checkbox"/> woody debris removal	<input checked="" type="checkbox"/> farming
<input type="checkbox"/> toxic pollutants	<input checked="" type="checkbox"/> nutrient enrichment

<b>Site:</b> PIR 2788-Apple Creek, Wooster Twp, Wayne County		<b>Date:</b> May 21, 2020	
<b>Wetland:</b>	A	<b>Rater:</b>	A. Dietz-Oergel, K. Simon

37 subtotal first page

<span style="border: 1px solid black; padding: 2px;">37</span>	<span style="border: 1px solid black; padding: 2px;">0</span>
Subtotal	Points

**Metric 5. Special Wetlands. (max 10 pts.)**

*Check all that apply and score as indicated*

- Bog (10 pts)
- Fen (10 pts)
- Old Growth Forest (10 pts)
- Mature forested wetland (5 pts)
- Lake Erie coastal/tributary wetland-unrestricted hydrology (10 pts)
- Lake Erie coastal/tributary wetland-restricted hydrology (5 pts)
- Lake Plain Sand Prairies (Oak Openings) (10 pts)
- Relict Wet Prairies (10 pts)
- Known occurrence state/federal threatened or endangered species (10)
- Significant migratory songbird/waterfowl habitat or usage (10 pts)
- Category 1 Wetland. See Question 1 of Qualitative Rating. (-10 pts)

<span style="border: 1px solid black; padding: 2px;">40</span>	<span style="border: 1px solid black; padding: 2px;">3</span>
Subtotal	Points

**Metric 6. Plant Communities, interspersions, microtopography. (max 20 pts.)**

6a. Wetland Vegetation Communities

Score all present using 0 to 3 scale

- Aquatic bed
- 2 Emergent
- Shrub
- 2 Forest
- Mudflats
- Open water
- Other (list) \_\_\_\_\_

**Vegetation Community Cover Scale**

0	Absent or comprises <0.1 ha (0.2471 acres) contiguous area
1	Present and either comprises small part of wetland's vegetation and is of moderate quality, or comprises a significant part but is of low quality
2	Present and either comprises significant part of wetland's vegetation and is of moderate quality or comprises a small part and is of high quality
3	Present and comprises significant part, or more, of wetland's vegetation and is of high quality

6b. Horizontal (plan view) interspersions

Select only one

- High (5)
- Moderately high (4)
- Moderate (3)
- Moderately low (2)
- x Low (1)
- None (0)

**Narrative Description of Vegetation Quality**

low	Low spp diversity and/or predominance of nonnative or disturbance tolerant native species
moderate	Native spp are dominant component of the vegetation, although nonnative and/or disturbance tolerant native spp can also be present, and species diversity moderate to moderately high, but generally w/o presence of rare threatened or endangered spp
high	A predominance of native species, with nonnative spp and/or disturbance tolerant native spp absent or virtually absent, and high spp diversity and often, but not always, the presence of rare, threatened, or endangered spp

6c. Coverage of invasive plants.

Refer to Table 1 ORAM long form for list. Add or deduct points for coverage

- Extensive >75 % cover (-5)
- x Moderate 25-75% cover (-3)
- Sparse 5-25% cover (-1)
- Nearly Absent <5% cover (0)
- Absent (1)

**Mudflat and Open Water Class Quality**

0	Absent <0.1 ha (0.2471 acres)
1	Low 0.1 ha to <1 ha (0.2471 acres to 2.47 acres)
2	Moderate 1 ha to <4 ha (2.47 acres 9.88 acres)
3	High 4 ha (9.88 acres) or more

6d. Microtopography

Score all present using 0 to 3 scale

- Vegetated hummocks/tussocks
- Coarse woody debris >15 cm (6")
- 1 Standing dead > 25 cm (10") dbh
- Amphibian breeding pools

**Microtopography Cover Scale**

0	Absent
1	Present very small amounts or if more common of marginal quality
2	Present in moderate amounts, but not of highest quality or in small amounts of highest quality
3	Present in moderate or greater amounts and of highest quality

40 **GRAND TOTAL (max 100 pts)**

**End of Quantitative Rating. Complete Categorization Worksheets.**

Comments: \_\_\_\_\_

**Attachment D**  
**HHEI/QHEI Data Forms**



Stream & Location: STREAM 1 - P16 2788 (APPLE CREEK) RM: Date: 5/13/06 20
Scorers Full Name & Affiliation: K. SIMON - ECT
River Code: STORET #: Lat./ Long.: 18 Office verified location

1] SUBSTRATE Check ONLY Two substrate TYPE BOXES; estimate % or note every type present. Check ONE (Or 2 & average) ORIGIN QUALITY. Includes categories like BLDR/SLABS, BOULDER, COBBLE, GRAVEL, SAND, BEDROCK, LIMESTONE, SILT, etc. Comments: 15, 2, 1, 0. Substrate Maximum 20.

2] INSTREAM COVER Indicate presence 0 to 3: 0-Absent; 1-Very small amounts... Check ONE (Or 2 & average) AMOUNT. Includes categories like UNDERCUT BANKS, OVERHANGING VEGETATION, SHALLOWS, ROOTMATS, POOLS, ROOTWADS, BOULDERS, OXBOWS, AQUATIC MACROPHYTES, LOGS OR WOODY DEBRIS. Comments: 1, 2, 2, 1, 1. Cover Maximum 20.

3] CHANNEL MORPHOLOGY Check ONE in each category (Or 2 & average) SINUOSITY DEVELOPMENT CHANNELIZATION STABILITY. Includes categories like HIGH, MODERATE, LOW, NONE, EXCELLENT, GOOD, FAIR, POOR, NONE, RECOVERED, RECOVERING, RECENT OR NO RECOVERY, HIGH, MODERATE, LOW. Comments: 2, 5, 6, 3. Channel Maximum 20.

4] BANK EROSION AND RIPARIAN ZONE Check ONE in each category for EACH BANK (Or 2 per bank & average) RIPARIAN WIDTH FLOOD PLAIN QUALITY. Includes categories like EROSION, WIDE, MODERATE, NARROW, VERY NARROW, NONE, FOREST, SWAMP, SHRUB OR OLD FIELD, RESIDENTIAL, FENCED PASTURE, OPEN PASTURE, ROWCROP, CONSERVATION TILLAGE, URBAN OR INDUSTRIAL, MINING / CONSTRUCTION. Comments: 2, 3.5, 1.5. Riparian Maximum 10.

5] POOL / GLIDE AND RIFFLE / RUN QUALITY MAXIMUM DEPTH CHANNEL WIDTH CURRENT VELOCITY Recreation Potential Primary Contact Secondary Contact. Includes categories like > 1m, 0.7-1m, 0.4-0.7m, 0.2-0.4m, < 0.2m, POOL WIDTH > RIFFLE WIDTH, CHANNEL WIDTH, TORRENTIAL, VERY FAST, FAST, MODERATE, SLOW, INTERSTITIAL, INTERMITTENT, EDDIES. Comments: 5. Pool / Current Maximum 12.

Indicate for functional riffles; Best areas must be large enough to support a population of riffle-obligate species: Check ONE (Or 2 & average). NO RIFFLE [metric=0]. RIFFLE DEPTH RUN DEPTH RIFFLE / RUN SUBSTRATE RIFFLE / RUN EMBEDDEDNESS. Includes categories like BEST AREAS > 10cm, 5-10cm, < 5cm, MAXIMUM > 50cm, < 50cm, STABLE, MOD. STABLE, UNSTABLE, NONE, LOW, MODERATE, EXTENSIVE. Comments: 6. Riffle / Run Maximum 8.

6] GRADIENT (20 ft/mi) DRAINAGE AREA (1343 mi^2) VERY LOW - LOW, MODERATE, HIGH - VERY HIGH. %POOL: 25 %GLIDE: 25 %RUN: 20 %RIFFLE: 30. Gradient Maximum 10.

**AJ SAMPLED REACH**

Check ALL that apply

**METHOD**

- BOAT
- WADE
- L. LINE
- OTHER

**STAGE**

- 1st -sample pass-- 2nd
- HIGH
  - UP
  - NORMAL
  - LOW
  - DRY

**DISTANCE**

- 0.5 Km
- 0.2 Km
- 0.15 Km
- 0.12 Km
- OTHER

meters

**CANOPY**

- > 85%- OPEN
- 55%-<85%
- 30%-<55%
- 10%-<30%
- <10%- CLOSED

**CLARITY**

- 1st -sample pass-- 2nd
- < 20 cm
  - 20-<40 cm
  - 40-70 cm
  - > 70 cm/ CTB
  - SECCHI DEPTH

**CJ RECREATION**

AREA DEPTH  
POOL:  >100ft<sup>2</sup>  >3ft

**BJAESTHETICS**

- NUISANCE ALGAE
- INVASIVE MACROPHYTES
- EXCESS TURBIDITY
- DISCOLORATION
- FOAM / SCUM
- OIL SHEEN
- TRASH / LITTER
- NUISANCE ODOR
- SLUDGE DEPOSITS
- CSOs/SSOs/OUTFALLS

**DJ MAINTENANCE**

- PUBLIC / PRIVATE / BOTH / NA
- ACTIVE / HISTORIC / BOTH / NA
- YOUNG-SUCCESSION-OLD
- SPRAY / SNAG / REMOVED
- MODIFIED / DIPPED OUT / NA
- LEVEED / ONE SIDED
- RELOCATED / CUTOFFS
- MOVING-BEDLOAD-STABLE
- ARMoured / SLUMPS
- ISLANDS / SCoured
- IMPOUNDED / DESICCATED
- FLOOD CONTROL / DRAINAGE

Circle some & COMMENT

**EJ ISSUES**

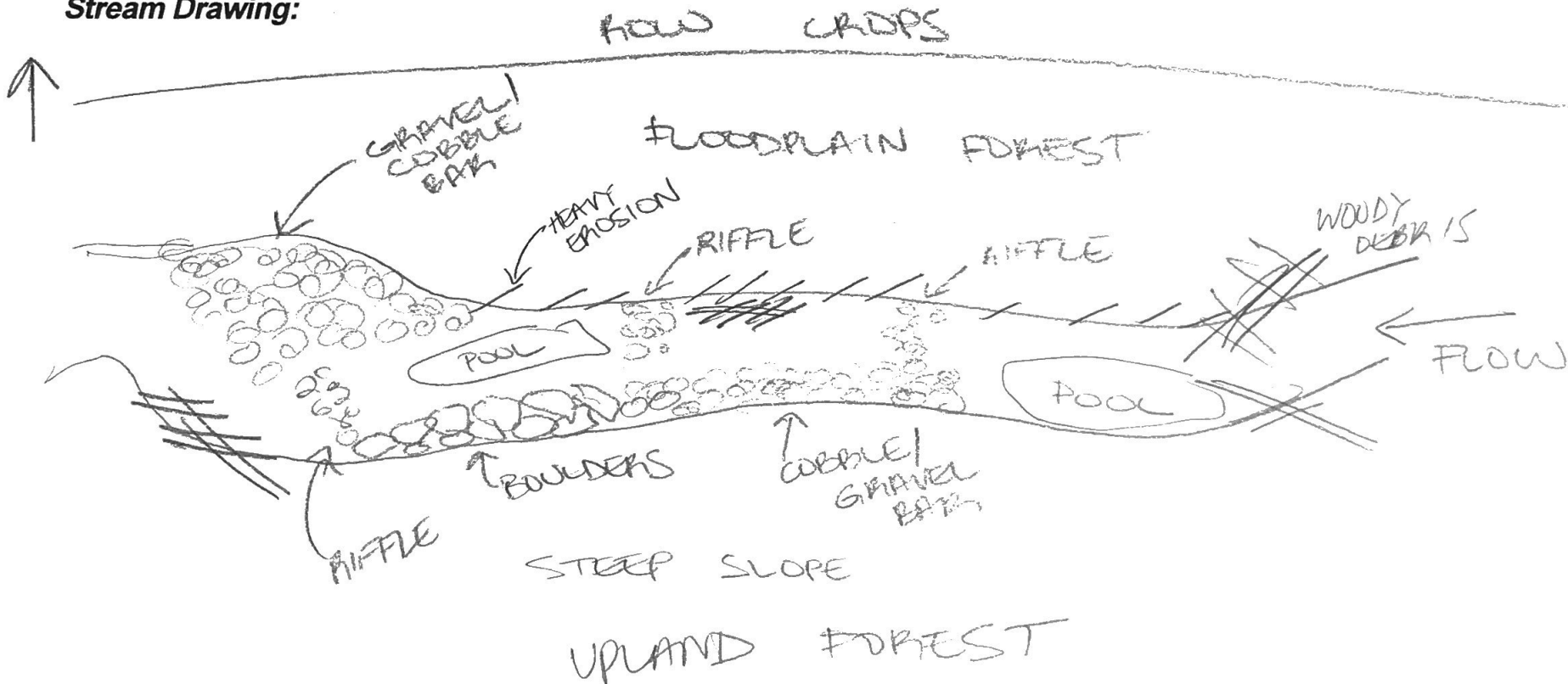
- WWTP / CSO / NPDES / INDUSTRY
- HARDENED / URBAN / DIRT&GRIME
- CONTAMINATED / LANDFILL
- BMPs-CONSTRUCTION-SEDIMENT
- LOGGING / IRRIGATION / COOLING
- BANK / EROSION / SURFACE
- FALSE BANK / MANURE / LAGOON
- WASH H<sub>2</sub>O / TILE / H<sub>2</sub>O TABLE
- ACID / MINE / QUARRY / FLOW
- NATURAL / WETLAND / STAGNANT
- PARK / GOLF / LAWN / HOME
- ATMOSPHERE / DATA PAUCITY

**FJ MEASUREMENTS**

- $\bar{x}$  width
- $\bar{x}$  depth
- max. depth
- $\bar{x}$  bankfull width
- bankfull  $\bar{x}$  depth
- W/D ratio
- bankfull max. depth
- floodprone  $\bar{x}^2$  width
- entrench. ratio

Legacy Tree:

**Stream Drawing:**





# Primary Headwater Habitat Evaluation Form

HHEI Score (sum of metrics 1, 2, 3) :

13

SITE NAME/LOCATION

STREAM 2 SITE NUMBER P1B2788 RIVER BASIN HUC 05040003 DRAINAGE AREA (mi<sup>2</sup>)

LENGTH OF STREAM REACH (ft) 200 LAT. 40.803081° LONG. -81.899995° RIVER CODE RIVER MILE

DATE 5/13/20 SCORER K. SIMON COMMENTS Modified Ephemeral Stream

NOTE: Complete All Items On This Form - Refer to "Field Evaluation Manual for Ohio's PWH Streams" for Instructions

STREAM CHANNEL

NONE / NATURAL CHANNEL  RECOVERED  RECOVERING  RECENT OR NO RECOVERY

MODIFICATIONS:

1. SUBSTRATE (Estimate percent of every type of substrate present. Check ONLY two predominant substrate TYPE boxes (Max of 40). Add total number of significant substrate types found (Max of 8). Final metric score is sum of boxes A & B.

TYPE	PERCENT	TYPE	PERCENT
<input type="checkbox"/> BLDR SLABS [16 pts]		<input checked="" type="checkbox"/> SILT [3 pt]	40
<input type="checkbox"/> BOULDER (>256 mm) [16 pts]		<input type="checkbox"/> LEAF PACK/WOODY DEBRIS [3 pts]	
<input type="checkbox"/> BEDROCK [16 pt]		<input checked="" type="checkbox"/> FINE DETRITUS [3 pts]	5
<input type="checkbox"/> COBBLE (65-256 mm) [12 pts]		<input checked="" type="checkbox"/> CLAY or HARDPAN [0 pt]	30
<input type="checkbox"/> GRAVEL (2-64 mm) [9 pts]	10	<input type="checkbox"/> MUCK [0 pts]	
<input type="checkbox"/> SAND (<2 mm) [6 pts]	15	<input type="checkbox"/> ARTIFICIAL [3 pts]	

Total of Percentages of Bldr Slabs, Boulder, Cobble, Bedrock 0

(A) 3

(B) 5

SCORE OF TWO MOST PREDOMINATE SUBSTRATE TYPES:

TOTAL NUMBER OF SUBSTRATE TYPES:

HHEI Metric Points

Substrate Max = 40

8

A + B

2. Maximum Pool Depth (Measure the maximum pool depth within the 61 meter (200 ft) evaluation reach at the time of evaluation. Avoid plunge pools from road culverts or storm water pipes) (Check ONLY one box):

<input type="checkbox"/> > 30 centimeters [20 pts]	<input type="checkbox"/> > 5 cm - 10 cm [15 pts]
<input type="checkbox"/> > 22.5 - 30 cm [30 pts]	<input type="checkbox"/> < 5 cm [5 pts]
<input type="checkbox"/> > 10 - 22.5 cm [25 pts]	<input checked="" type="checkbox"/> NO WATER OR MOIST CHANNEL [0 pts]

COMMENTS

MAXIMUM POOL DEPTH (centimeters):

0

Pool Depth Max = 30

0

3. BANK FULL WIDTH (Measured as the average of 3-4 measurements) (Check ONLY one box):

<input type="checkbox"/> > 4.0 meters (> 13') [30 pts]	<input type="checkbox"/> > 1.0 m - 1.5 m (> 3' 3" - 4' 8") [15 pts]
<input type="checkbox"/> > 3.0 m - 4.0 m (> 9' 7" - 13') [25 pts]	<input checked="" type="checkbox"/> ≤ 1.0 m (≤ 3' 3") [5 pts]
<input type="checkbox"/> > 1.5 m - 3.0 m (> 4' 8" - 9' 7") [20 pts]	

COMMENTS

AVERAGE BANKFULL WIDTH (meters)

1.7

Bankfull Width Max=30

5

This information must also be completed

RIPARIAN ZONE AND FLOODPLAIN QUALITY ☆NOTE: River Left (L) and Right (R) as looking downstream☆

RIPARIAN WIDTH

FLOODPLAIN QUALITY

L R (Per Bank)

L R (Most Predominant per Bank)

L R

Wide >10m

Mature Forest, Wetland

Conservation Tillage

Moderate 5-10m

Immature Forest, Shrub or Old Field

Urban or Industrial

Narrow <5m

Residential, Park, New Field

Open Pasture, Row Crop

None

Fenced Pasture

Mining or Construction

COMMENTS

FLOW REGIME (At Time of Evaluation) (Check ONLY one box):

<input type="checkbox"/> Stream Flowing	<input type="checkbox"/> Moist Channel, isolated pools, no flow (Intermittent)
<input type="checkbox"/> Subsurface flow with isolated pools (Interstitial)	<input checked="" type="checkbox"/> Dry channel, no water (Ephemeral)

COMMENTS

SINUOSITY (Number of bends per 61 m (200 ft) of channel) (Check ONLY one box):

<input checked="" type="checkbox"/> None	<input type="checkbox"/> 1.0	<input type="checkbox"/> 2.0	<input type="checkbox"/> 3.0
<input type="checkbox"/> 0.5	<input type="checkbox"/> 1.5	<input type="checkbox"/> 2.5	<input type="checkbox"/> >3

STREAM GRADIENT ESTIMATE

Flat (0.5 ft/100 ft)  Flat to Moderate  Moderate (2 ft/100 ft)  Moderate to Severe  Severe (10 ft/100 ft)



**ADDITIONAL STREAM INFORMATION (This Information Must Also be Completed):**

QHEI PERFORMED? -  Yes  No QHEI Score \_\_\_\_\_ (If Yes, Attach Completed QHEI Form)

**DOWNSTREAM DESIGNATED USE(S)**

- WWH Name: Apple Creek Distance from Evaluated Stream 0.06 mi
- CWH Name: \_\_\_\_\_ Distance from Evaluated Stream \_\_\_\_\_
- EWH Name: \_\_\_\_\_ Distance from Evaluated Stream \_\_\_\_\_

**MAPPING: ATTACH COPIES OF MAPS, INCLUDING THE ENTIRE WATERSHED AREA. CLEARLY MARK THE SITE LOCATION**

USGS Quadrangle Name: Wooster NRCS Soil Map Page: \_\_\_\_\_ NRCS Soil Map Stream Order \_\_\_\_\_  
 County: WAYNE Township / City: Wooster Twp.

**MISCELLANEOUS**

Base Flow Conditions? (Y/N): N Date of last precipitation: 05/11/2020 Quantity: 0.20

Photograph Information: \_\_\_\_\_

Elevated Turbidity? (Y/N): \_\_\_\_\_ Canopy (% open): 100

Were samples collected for water chemistry? (Y/N): N (Note lab sample no. or id. and attach results) Lab Number: \_\_\_\_\_

Field Measures: Temp (°C) \_\_\_\_\_ Dissolved Oxygen (mg/l) \_\_\_\_\_ pH (S.U.) \_\_\_\_\_ Conductivity (µmhos/cm) \_\_\_\_\_

Is the sampling reach representative of the stream (Y/N) Y If not, please explain: \_\_\_\_\_

Additional comments/description of pollution impacts: \_\_\_\_\_

**BIOTIC EVALUATION**

Performed? (Y/N): Y (If Yes, Record all observations. Voucher collections optional. NOTE: all voucher samples must be labeled with the site ID number. Include appropriate field data sheets from the Primary Headwater Habitat Assessment Manual)

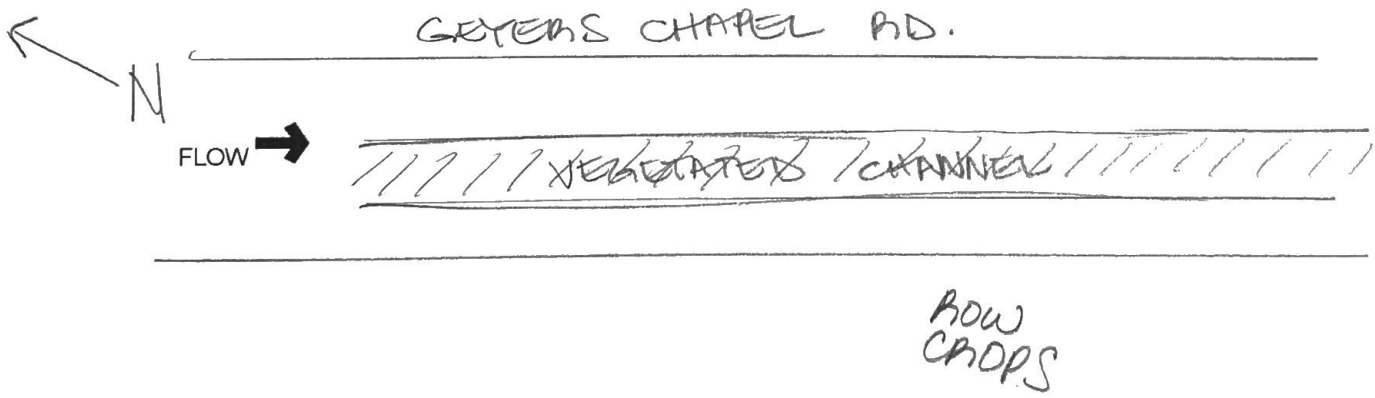
Fish Observed? (Y/N) N Voucher? (Y/N) \_\_\_\_\_ Salamanders Observed? (Y/N) N Voucher? (Y/N) \_\_\_\_\_

Frogs or Tadpoles Observed? (Y/N) N Voucher? (Y/N) \_\_\_\_\_ Aquatic Macroinvertebrates Observed? (Y/N) N Voucher? (Y/N) \_\_\_\_\_

Comments Regarding Biology: \_\_\_\_\_

**DRAWING AND NARRATIVE DESCRIPTION OF STREAM REACH (This must be completed):**

Include important landmarks and other features of interest for site evaluation and a narrative description of the stream's location



**Attachment E**  
**USFWS IPAC Results**



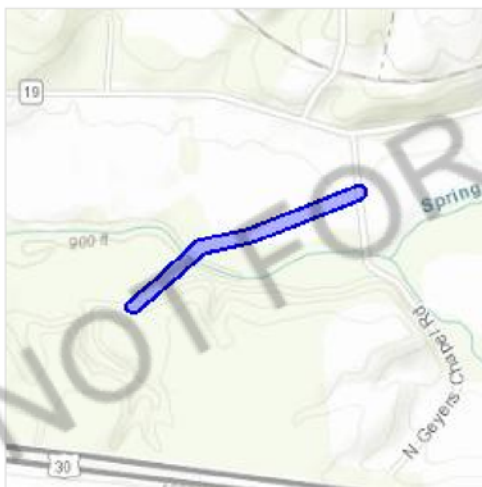
# IPaC resource list

This report is an automatically generated list of species and other resources such as critical habitat (collectively referred to as *trust resources*) under the U.S. Fish and Wildlife Service's (USFWS) jurisdiction that are known or expected to be on or near the project area referenced below. The list may also include trust resources that occur outside of the project area, but that could potentially be directly or indirectly affected by activities in the project area. However, determining the likelihood and extent of effects a project may have on trust resources typically requires gathering additional site-specific (e.g., vegetation/species surveys) and project-specific (e.g., magnitude and timing of proposed activities) information.

Below is a summary of the project information you provided and contact information for the USFWS office(s) with jurisdiction in the defined project area. Please read the introduction to each section that follows (Endangered Species, Migratory Birds, USFWS Facilities, and NWI Wetlands) for additional information applicable to the trust resources addressed in that section.

## Location

Wayne County, Ohio



## Local office

Ohio Ecological Services Field Office

☎ (614) 416-8993

📠 (614) 416-8994

4625 Morse Road, Suite 104  
Columbus, OH 43230-8355

# Endangered species

**This resource list is for informational purposes only and does not constitute an analysis of project level impacts.**

The primary information used to generate this list is the known or expected range of each species. Additional areas of influence (AOI) for species are also considered. An AOI includes areas outside of the species range if the species could be indirectly affected by activities in that area (e.g., placing a dam upstream of a fish population, even if that fish does not occur at the dam site, may indirectly impact the species by reducing or eliminating water flow downstream). Because species can move, and site conditions can change, the species on this list are not guaranteed to be found on or near the project area. To fully determine any potential effects to species, additional site-specific and project-specific information is often required.

Section 7 of the Endangered Species Act **requires** Federal agencies to "request of the Secretary information whether any species which is listed or proposed to be listed may be present in the area of such proposed action" for any project that is conducted, permitted, funded, or licensed by any Federal agency. A letter from the local office and a species list which fulfills this requirement can **only** be obtained by requesting an official species list from either the Regulatory Review section in IPaC (see directions below) or from the local field office directly.

For project evaluations that require USFWS concurrence/review, please return to the IPaC website and request an official species list by doing the following:

1. Draw the project location and click CONTINUE.
2. Click DEFINE PROJECT.
3. Log in (if directed to do so).
4. Provide a name and description for your project.
5. Click REQUEST SPECIES LIST.

Listed species<sup>1</sup> and their critical habitats are managed by the [Ecological Services Program](#) of the U.S. Fish and Wildlife Service (USFWS) and the fisheries division of the National Oceanic and Atmospheric Administration (NOAA Fisheries<sup>2</sup>).

Species and critical habitats under the sole responsibility of NOAA Fisheries are **not** shown on this list. Please contact [NOAA Fisheries](#) for [species under their jurisdiction](#).

1. Species listed under the [Endangered Species Act](#) are threatened or endangered; IPaC also shows species that are candidates, or proposed, for listing. See the [listing status page](#) for more information.
2. [NOAA Fisheries](#), also known as the National Marine Fisheries Service (NMFS), is an office of the National Oceanic and Atmospheric Administration within the Department of Commerce.

The following species are potentially affected by activities in this location:

## Mammals

NAME

STATUS



Indiana Bat *Myotis sodalis* Endangered  
 There is **final** critical habitat for this species. Your location is outside the critical habitat.  
<https://ecos.fws.gov/ecp/species/5949>

Northern Long-eared Bat *Myotis septentrionalis* Threatened  
 This species only needs to be considered if the following condition applies:

- Incidental take of the northern long-eared bat is not prohibited at this location. Federal action agencies may conclude consultation using the streamlined process described at <https://www.fws.gov/midwest/endangered/mammals/nleb/s7.html>

No critical habitat has been designated for this species.  
<https://ecos.fws.gov/ecp/species/9045>

## Flowering Plants

NAME	STATUS
Eastern Prairie Fringed Orchid <i>Platanthera leucophaea</i> No critical habitat has been designated for this species. <a href="https://ecos.fws.gov/ecp/species/601">https://ecos.fws.gov/ecp/species/601</a>	Threatened

## Critical habitats

Potential effects to critical habitat(s) in this location must be analyzed along with the endangered species themselves.

THERE ARE NO CRITICAL HABITATS AT THIS LOCATION.

## Migratory birds

Certain birds are protected under the Migratory Bird Treaty Act<sup>1</sup> and the Bald and Golden Eagle Protection Act<sup>2</sup>.

Any person or organization who plans or conducts activities that may result in impacts to migratory birds, eagles, and their habitats should follow appropriate regulations and consider implementing appropriate conservation measures, as described [below](#).

1. The [Migratory Birds Treaty Act](#) of 1918.
2. The [Bald and Golden Eagle Protection Act](#) of 1940.

Additional information can be found using the following links:

- Birds of Conservation Concern <http://www.fws.gov/birds/management/managed-species/birds-of-conservation-concern.php>

**Attachment F**  
**Potential Bat Habitat Tree Table**



Table 3. Potential Habitat Trees within PIR 2788

Tree ID	Species	DBH (in)	Location	Tree Condition	Habitat / Maternity Tree	Potential Habitat Features
1	<i>Prunus serotina</i>	12	Forest stand southwest of Apple Creek	Critical	Habitat	Small amount of cavities and dead wood.
2	<i>Carya ovata</i>	18	Forest stand southwest of Apple Creek	Excellent	Habitat	Moderate amount of exfoliating bark
3	<i>Tilia americana</i>	14	Forest stand southwest of Apple Creek	Good	Habitat	Small amount of cavities and dead wood.
4	<i>Tilia americana</i>	36	Forest stand southwest of Apple Creek	Poor	Habitat	Moderate amount of cavities and dead wood.
5	<i>Fraxnius sp.</i>	18	Forest stand southwest of Apple Creek	Dead	Habitat	Moderate amount of exfoliating bark and dead wood.
6	<i>Platanus occidentalis</i>	42	Forest stand southwest of Apple Creek	Excellent	Habitat	Small amount of cavities and dead wood.
7	<i>Tilia americana</i>	16	Forest stand southwest of Apple Creek	Poor	Habitat	Small amount of cavities and dead wood.
8	<i>Acer rubrum</i>	16	Forest stand southwest of Apple Creek	Excellent	Habitat	Small amount of cavities.
9	<i>Acer rubrum</i>	16	Forest stand northeast of Apple Creek within northeastern corner of Wetland A	Dead	Habitat	Small amount of cavities and dead wood.
10	<i>Acer negundo</i>	20	Forest stand northeast of Apple Creek within western side of Wetland A	Critical	Habitat	Small amount of cavities and dead wood.

Source: ECT 2020

**ATTACHMENT E**  
**OHIO HISTORIC PRESERVATION OFFICE LITERATURE REVIEW**



> **Phase I Archaeological Survey**  
**PIR 2788 – Apple Creek**  
**Wooster Township, Wayne County, Ohio**

February 2024  
ECT No. 200336-0002

The East Ohio Gas Company, d/b/a Dominion Energy Ohio  
320 Springside Drive, Suite 320  
Akron, Ohio 44333



161 East Aurora Road  
Northfield, OH 44067  
[www.ectinc.com](http://www.ectinc.com)

## Document Review

The dual signatory process is an integral part of Environmental Consulting & Technology, Inc.'s (ECT's) Document Review Policy. All ECT documents undergo technical/peer review prior to dispatching these documents to any outside entity.

This document has been authored and reviewed by the following employees:

\_\_\_\_\_  
Matthew Lockett  
Author

\_\_\_\_\_  
*Matthew M. Lockett*  
Signature

\_\_\_\_\_  
February 13, 2024  
Date

\_\_\_\_\_  
James Marine  
Peer Review

\_\_\_\_\_  
*James J Marine*  
Signature

\_\_\_\_\_  
February 13, 2024  
Date



# Phase I Archaeological Survey PIR 2788 – Apple Creek Wooster Township, Wayne County, Ohio

**Prepared For:**

The East Ohio Gas Company, d/b/a Dominion Energy Ohio  
320 Springside Drive, Suite 320  
Akron, Ohio 44333

**Lead Agency:**

United States Army Corps of Engineers  
Huntington Regulatory District  
502 Eighth Street  
Huntington, WV 25701

**Prepared By:**

Environmental Consulting & Technology, Inc  
161 East Aurora Road  
Northfield, OH 44067

**Authors:**

Matthew M. Lockett  
James T. Marine

James T. Marine MS/RPA  
Principal Investigator / Geomorphologist

FEBRUARY 2024

## Executive Summary

The East Ohio Gas Company, d/b/a Dominion Energy Ohio (DEO) is proposing to replace approximately 1,188.7 meters (m) (3,900 feet [ft]) of twelve (12)-inch natural gas steel pipeline under DEO's Pipeline Infrastructure Replacement (PIR) program. The purpose of the program is to replace existing pipe to ensure the safety and reliability of pipeline operations. The PIR 2788 – Apple Creek project (Project) is located in Wooster Township, Wayne County. The Project is being permitted under United States Army Corps of Engineers (USACE) Nationwide Permit 12 and is subject to review by the Ohio Power Siting Board.

Initial background research for the Project identified one (1) previously recorded archaeological site within the limits of disturbance (LOD) between Apple Creek and South Geyers Chapel Road. Site 33WE0085, the Taggart Farm Site, is a prehistoric site of unknown function that has not been evaluated for listing in the National Register of Historic Places (NRHP). Site records indicate the site was initially identified by the landowner in the 1960s but was not recorded until 1979. The site was recorded based on information provided by the landowner but was never field checked. The site boundary as depicted in the site records is approximated and extends across nearly 32 acres of residential and agricultural lands, of which approximately 2.27 acres intersect the Project.

As the exact location and extent of site 33WE0085 is not presently known, DEO requested Environmental Consulting & Technology, Inc (ECT) conduct a Phase I archaeological survey of the approximately 2.27 acres of site 33WE0085 that intersect the Project (Survey Area). The purpose of the survey is to relocate any portions of site 33WE0085 that may remain intact within the Survey Area and to make recommendations as to the need for further work or avoidance of the site.

The Phase I archaeological survey was conducted in January and February 2024. A total of 45 STPs were excavated within the Survey Area. Shovel testing recovered four (4) prehistoric artifacts and identified one (1) potential cultural feature within the Survey Area in an area bisected by the existing pipeline. Given the nebulous nature of the original site boundary, it is not clear if the artifacts recovered represent the original location of site 33WE0085 or if the occupation identified during this investigation is one (1) of many possible site locations situated within the approximately 32-acre area mapped as site 33WE0085.



Due to disturbances from the existing pipeline, the limited archaeological context inherent in the channel lag deposits underlying the Study Area resulting from the lateral migration of Apple Creek, the low density of artifacts, and the extent of negative shovel testing, it is ECT's conclusion that the only portion of site 33WE0085 within the Survey Area that retains the potential to contain significant information is the potential feature identified in STP 11. Therefore, ECT recommends the feature be avoided. If the potential feature cannot be avoided, ECT recommends the anomaly be revisited and fully exposed and excavated to determine if the charcoal concentration is cultural in origin and to collect any additional data (e.g., datable organic material or floral and faunal remains).

DEO has elected to avoid impacts to the potential feature. Temporary construction fencing will be installed around STP 11. The avoidance buffer will extend 10 m (32.8 ft) to the east and west of STP 11 between the existing pipeline trench and the southern boundary of the LOD. No excavation will occur within this avoidance buffer. However, DEO may place timber matting on the ground surface to allow for equipment to traverse the LOD. As the potential feature was identified at the base of the plowzone, approximately 27 centimeters (10.6 inches) below surface, the timber matting will adequately distribute the weight of machinery over the site and avoid impacts to the potential feature. Given the limited amount of testing conducted within the mapped 32-acres boundary of site 33WE0085, the site cannot presently be evaluated for listing in the NRHP. However, with the avoidance plan implemented, ECT recommends the portions of site 33WE0085 remaining within the Project LOD do not contribute to the site's potential eligibility for listing in the NRHP.

## Table of Contents

<b>Executive Summary .....</b>	<b>i</b>
<b>1.0 Introduction .....</b>	<b>1</b>
<b>2.0 Environmental Setting .....</b>	<b>3</b>
2.1 Physiography and Geology.....	3
2.2 Soils.....	3
2.3 Pleistocene and Holocene Paleoenvironment.....	3
<b>3.0 Cultural Context .....</b>	<b>6</b>
3.1 Prehistoric Context.....	6
3.1.1 Paleoindian Period (11,500 to 10,000 years BP) .....	6
3.1.2 Early Archaic Period (10,000 to 8,000 years BP) .....	8
3.1.3 Middle Archaic Period (8,000 to 5,500 years BP) .....	10
3.1.4 Late Archaic Period (3,500 to 1,000 years BP).....	10
3.1.5 Transitional Period (3,000 to 2,000 years BP) .....	11
3.1.6 Early Woodland Period (2,600 to 2,100 years BP) .....	12
3.1.7 Middle Woodland Period (2,100 to 1,500 years BP).....	12
3.1.8 Late Woodland Period (1,500 to 800 years BP).....	13
3.1.9 Late Prehistoric Period (800 to 350 years BP).....	14
3.2 Historic Context.....	15
3.2.1 Frontier (ca. 1775–1795) .....	15
3.2.2 Settlement (1796–1819) .....	15
3.2.3 Immigration .....	16
3.2.4 The Industrial Period (ca. 1850–1930).....	17
3.2.5 Mid-Twentieth Century (1930–1960).....	18
3.2.6 Late-Twentieth and Early-Twenty-First Centuries (1960-present day) .....	19
<b>4.0 Methodology .....</b>	<b>20</b>
4.1 Background Research Methods.....	20
4.2 Field Methods.....	20
4.3 Artifact Analysis and Curation.....	21
<b>5.0 Results.....</b>	<b>22</b>
5.1 Results of Background Research .....	22
5.2 Results of Fieldwork .....	25



**6.0 Summary and Recommendations..... 30**  
**7.0 References Cited ..... 32**

**Appendices**

- Appendix A Background Figures
- Appendix B Photographs
- Appendix B Representative Soil Profiles
- Appendix D Artifact Inventory

**List of Tables**

Table 1: Previously Completed Cultural Resources Surveys within DSA .....22  
Table 2: Previously Recorded Archaeological Sites within the DSA.....23  
Table 3: Previously Recorded Above Ground Resources in the DSA.....24

## List of Acronyms and Abbreviations

BP	years before present
c.	circa
cm	centimeter
DEO	East Ohio Gas Company, d/b/a Dominion Energy Ohio
DSA	Desktop Survey Area
ECT	Environmental & Consulting Technology, Inc.
ft	foot
in	inch
km	kilometer
LOD	Limits of Disturbance
m	meter
mi	mile
NRCS	Natural Resources Conservation Service
NRHP	National Register of Historic Places
OAI	Ohio Archaeological Inventory
OHPO	Ohio Historic Preservation Office
PIR	Pipeline Infrastructure Replacement
Project	PIR 2788 – Apple Creek
STP	Shovel Test Pit
Survey Area	Approximately 2.27 acres of Project intersecting site 33WE0085
USACE	United States Army Corps of Engineers
USDA	United States Department of Agriculture
USGS	United States Geological Survey



## 1.0 Introduction

The East Ohio Gas Company, d/b/a Dominion Energy Ohio (DEO) is proposing to replace approximately 1,188.7 meters (m) (3,900 feet [ft]) of twelve (12)-inch natural gas steel pipeline under DEO's Pipeline Infrastructure Replacement (PIR) program. The purpose of the program is to replace existing pipe to ensure the safety and reliability of pipeline operations. The PIR 2788 – Apple Creek project (Project) is located in Wooster Township, Wayne County (*USGS Topographic Map, Appendix A, Figure 1*). The Project requires a United States Army Corps of Engineers (USACE) Nationwide Permit 12 for Oil or Natural Gas Pipeline Activities and is subject to review by the Ohio Power Siting Board.

DEO proposes to install the pipeline within the road-right-of way of North Hillcrest Drive, a newly acquired utility easement on private property, and the existing utility easement between a section of Apple Creek and South Geyers Chapel Road (*Project Location Map, Appendix A, Figure 2*). To replace the pipeline, the existing steel pipeline will be removed or abandoned in place and a new pipe will be replaced within a 0.91-m (3-ft) wide, 1.8-m (5.5-ft) deep trench. Construction activities will be limited to a 3-m (10-ft) wide corridor along North Hillcrest Drive and an 18.3-m (60-ft) wide limit of disturbance (LOD) in the utility easements with a combined area measuring approximately 4.26-acres. Two (2) potential access roads, with a combined area of 0.98 acres, extending west from South Geyers Chapel Road to the pipeline replacement LOD are also being evaluated for potential use during installation of the new pipe. If incorporated into the Project design, ground disturbances derived from the proposed access road will be limited to surficial disturbances from the movement of vehicles and equipment and the installation, use, and removal of timber matting to cross any wetlands within the proposed access road corridors.

Initial background research for the Project identified one (1) previously recorded archaeological site within the LOD between Apple Creek and South Geyers Chapel Road. Site 33WE0085, the Taggart Farm Site, is a prehistoric site of unknown function that has not been evaluated for listing in the National Register of Historic Places (NRHP). Site records indicate the site was initially identified by the landowner in the 1960s but was not recorded until 1979. The site was recorded based on information provided by the landowner but was never field checked. The site boundary as depicted in the Ohio Archaeological Inventory (OAI) records is approximated and extends across nearly 32 acres of

residential and agricultural lands, of which, approximately 2.27 acres intersect the LOD (*Survey Area Map, Appendix A, Figure 3*).

General Condition 20(c) of Nationwide Permit 12 requires the applicant to submit a pre-construction notice to the district engineer should the permitted activity have the potential to cause effects to resources listed in, determined eligible, or potentially eligible for listing in the NRHP. Since the exact location and extent of site 33WE0085 is not presently known, DEO requested Environmental Consulting & Technology, Inc (ECT) conduct a Phase I archaeological survey of the approximately 2.27 acres of site 33WE0085 that intersect the Project's LOD (Survey Area). The purpose of the survey is to relocate any portions of site 33WE0085 that may remain intact within the Survey Area and to make recommendations as to the need for further work or avoidance of the site.

The Phase I archaeological survey was conducted in January and February 2024. A total of 45 shovel test pits (STPs) were excavated within the Survey Area. Shovel testing recovered four (4) prehistoric artifacts and identified one (1) potential cultural feature within the Survey Area in an area bisected by the existing pipeline.

The Phase I archaeological survey was conducted according to the Ohio Historic Preservation Office's (OHPO's) *Archaeological Guidelines* (OHPO 2022) by personnel that meet or exceed the Secretary of the Interior's Professional Qualification Standards (36 CFR Part 61) for conducting archaeological research. Mr. James T. Marine, MS/RPA served as the Principal Investigator and geomorphologist for the Project. The fieldwork was conducted by Mr. Troy Linebaugh, MA and Mr. Ryan Oergel, MA.

## 2.0 Environmental Setting

### 2.1 Physiography and Geology

The Survey Area is located in the Glaciated Allegheny Plateaus section of the Appalachian Plateau physiographic region. More specifically the Survey Area is situated within the Killbuck-Glaciated Pittsburgh Plateaus subsection of the Glaciated Allegheny Plateaus section. This subsection is characterized by ridges and flat uplands covered in a thin mantle of Wisconsin-age glacial drift. The uplands are typically dissected by steep valleys that vary from narrow, rock lined valley walls to broad, drift filled valleys (Brockman 1998).

The Survey Area is underlain by the Logan and Cuyahoga Formations of Mississippian Period. This formation is composed of interbedded shale with minor components of siltstone and major components of sandstone (Slucher et al. 2006).

### 2.2 Soils

A review of the United States Department of Agriculture-Natural Resources Conservation Service (USDA-NRCS) web soil survey identified three (3) soil types within the Survey Area (USDA-NRCS 2024). The Survey Area is predominantly underlain by Tioga silt loam, occasionally flooded (Tg), with smaller areas mapped across Bogart Loam, 2 to 6 percent slopes (Btb) and Lobdell silt loam, occasionally flooded (Le) (*NRCS Mapped Soils in Survey Area, Appendix A, Figure 4*). Tioga and Lobdell series soils are both composed of deep, moderately well drained to well drained alluvium. Tioga series soils exhibit a typical pedogenic sequence of Ap/Bw1/Bw2/C while Lobdell series soils typically exhibit a sequence of A/Bw/BC/Cg1/Cg2 (USDA-NRCS 2024). Bogart series soils are deep, moderately well drained soils formed in stratified glacial outwash deposits, outwash plains, and remnant beach ridges and exhibit a typical pedogenic sequence of Ap1/Ap2/Bt1/Bt2/Bt3/BC/C (USDA-NRCS 2024).

### 2.3 Pleistocene and Holocene Paleoenvironment

The Pleistocene Epoch witnessed a series of cold periods and associated "ice ages," the most recent of which terminated approximately 14,000 to 12,000 years before present (BP). One of the most dramatic effects of these "ice ages" was the lowering of ocean levels worldwide as rainwater was frozen and trapped in glaciers and continental ice sheets. Milliman and Emery (1968) argued on the basis of 80 radiocarbon samples taken along the Atlantic continental shelf that sea levels 30,000 to



35,000 years BP were close to those at present. Sea levels dropped subsequently as much as 130 meters during the final glaciation circa (c.) 16,000 years BP. Along the Atlantic coast, ocean beaches lay at the edge of the modern continental shelf, perhaps 100 kilometers (km) (62.1 miles [mi]) east of the current New Jersey coastline. Belknap and Kraft (1977) questioned the maximum depth of sea level drop but agreed with the overall temporal trends.

In the glaciated portions of Ohio, the ebb and flow of glacial advancement and retreat are noted by series or morainal features interspersed with interglacial lakes. At the end of the Pleistocene, c. 12,000 to 10,000 years BP, the Great Lakes began to form from glacial meltwater, and the regional network of drainages began to establish. At this time, the region was covered with conifer forests dominated by spruce, fir, tamarack, cedar, hemlock, and larch (Hansen 1995). As the climate began to warm at the end of the Pleistocene, the coniferous forests in Ohio were quickly displaced by deciduous forests, typically dominated by species of oak, similar to that of today's forests (Hansen 1995).

Evidence suggests that faunal resources were diverse during the early Holocene, including both those adapted to boreal and deciduous forests (Delcourt and Delcourt 1986; Eisenberg 1978). Guilday et al. (1977) note that the distribution of fauna depended on biotic gradients related to variations in topographic and edaphic conditions. Eisenberg (1978) cites evidence of mammoth and white-tailed deer co-occurring in the Northeast. The temperate forest faunal remains and pollen dating to c. 11,300 years BP at Meadowcroft may have been the localized result of favorable temperature and moisture regimes within the Cross Creek drainage (Adovasio et al. 1985).

There is evidence to suggest that the period between 9,000 and 5,500 years BP was characterized by a climate warmer and drier than present. Evidence for this Hypsithermal Period is strong in the Midwest where pollen data show an advance of the prairie eastward into Illinois, reaching its maximum extent at about 7,000 years BP (Bartlein et al. 1984; King 1980). In the eastern United States, evidence for a warmer, drier period at this time includes a peak in grasses at Bear Meadows in Centre County, Pennsylvania (Kovar 1965), and xeric vegetation on the Cumberland Plateau in Tennessee (Delcourt 1979). Davis et al. (1980) point to an increase in the altitudinal range of hemlock and white pine as evidence of a warmer, drier period between 9,000 and 5,000 years BP in New England. Watts (1979), in his examination of pollen diagrams in the Middle Atlantic region, supports the hypothesis of a warmer, drier climate between 8,500 and 5,500 years BP.

Effects of the warmer, drier climate included a decrease in the number of low-order streams, lower water volume in streams generally, a decrease in biomass on ridges, and a lowering of the water table (Graetzer 1986; Watts 1983). Evidence provided by correlations of pollen core data with pollen from surface samples from known vegetation types suggests that the overall composition of the vegetation did not change radically (Bradstreet and Davis 1975). However, changes in hydrology and decreases in productivity would likely have had some effect on the distribution of prehistoric populations. Specifically, upland areas would have become relatively less attractive, whereas major riverine areas such as floodplains and terraces would have been relatively more attractive.

By 5,000 years BP, a relatively stable primary forest was established in the region leading to today's classification of the Project area as part of the Southern Great Lakes lowland forests ecoregion within the greater temperate broadleaf and mixed forest ecoregion (Noss 2023). This region is characterized by a dominance of deciduous forests and contains a relatively low level of species diversification. While little forest remains in the region due to extensive agricultural use, historically the region's forests contained up to 80 percent sugar maple and beech with stands of oak and hickory in drier areas of the region (Noss 2023). Extensive historic draining of wetlands and clearing of forest land in the Project area has significantly altered the natural landscape in the past 200 years.

## 3.0 Cultural Context

### 3.1 Prehistoric Context

#### 3.1.1 Paleoindian Period (11,500 to 10,000 years BP)

The Paleoindian period is the earliest documented occupation in the Ohio region and the Eastern U.S. This period is defined by distinctive cultural adaptations focused on the environmental milieu that characterized the late Pleistocene and early Holocene climatic periods. The key artifact type that identifies this period is the fluted projectile point, usually manufactured from a high quality crypto-crystalline lithic material, e.g., jasper, chert, or chalcedony. Although the Paleoindian stage is of short duration, three (3) distinct Paleoindian sub-phases or periods have been proposed by Gardner for this period in the Middle Atlantic region, based on excavations at the Thunderbird site complex in the Shenandoah Valley of Virginia (Gardner 1974), a periodization that is relevant to the Ohio region as well. Gardner's three-part subdivision of the Paleoindian stage was, in part, based on stratigraphic excavations at the Thunderbird site (Gardner 1974) though it had precedent in earlier work conducted in Nova Scotia. Gardner noted that MacDonald had subdivided the Paleoindian stage into three (3) separate phases based on his work with the Debert site materials in Nova Scotia (Gardner 1974; MacDonald 1968). MacDonald's Early Phase included only the Clovis points in his sequence. The second phase was defined by Folsom points and their cognate variants, while the Dalton-Hardaway sub-phase is the final chronological period of the Paleoindian stage, characterized by the minimally fluted Dalton and Hardaway projectile points. Many other tool categories are associated with these projectile points that usually cannot be taken by themselves as diagnostic Paleoindian indicators. It is notable that Tankersley (1996; see also Jefferies 2008) has also outlined a three sub-period sequence for the Lower Ohio River Valley, one that follows Gardner's chronological subdivisions of the Paleoindian stage and the sub-phases that he identified within it (Jefferies 2008:69–87; Tankersley 1996).

An analysis of fluted point distributions in Ohio suggests that Paleoindian site locations frequently are found in major stream valleys and at stream confluences close to quality flint resources. In Virginia, Gardner's (1974) quarry base camp model is applicable to a variety of geographic settings that includes Ohio, a model that Goodyear (1979) adopted for the Carolina region. As an example of this model, it is common that many diagnostic Paleoindian points have been recovered far removed from



the original lithic source from which they were made. One (1) of the lamellar blades associated with the Clovis occupation at Big Bone Lick in northern Kentucky was, as noted by Tankersley et al. (2009), struck from a core of Fort Payne chert, a source that is nearly 420 km (261 mi) distant from the site where it was recovered. Recovery of this lithic material far from its source reflects the high mobility of Early Paleoindian hunting groups. In addition, many points recovered distant from the quarry source exhibit curation or re-sharpening to preserve its useful life rather than selecting local lithic sources. Paleoindian sites are rarely documented in regions such as swampy lowlands or rugged highlands (Payne 1987) though the location of some upland Clovis point finds suggests that some use was made of these environmental settings. In particular, the Three Saylor's site in Harlan County, Kentucky contained a moderate-sized Clovis component situated on a terrace along a small tributary of the Kentucky River (Tankersley 2008). Based on the sourcing of lithic material recovered at Paleoindian sites in northern Ohio, Stothers et al. (2001) hypothesize that two (2) parallel waves of immigration into northern Ohio from southern and central Ohio occurred during the Paleoindian and Early Archaic periods.

Paleoindian groups relied on late Pleistocene faunal and floral resources for subsistence. In terms of faunal remains, there are several sites that have good associations of extinct faunal specimens and Clovis tools in direct association in the region. This sample would include the well-known Big Bone Lick site in Boone County, Kentucky, where late Pleistocene fauna, including numerous mastodon remains, have been recovered since the beginning of the nineteenth century. Tankersley et al. (2009) reported on the association and dating of stratigraphic contexts at the site that contain Clovis points along with mastodon and other extinct mammalian species that were present during the late Pleistocene era. Although there is no direct evidence that the faunal remains reflect game that was actually procured through hunting, the stratigraphic contexts of the site clearly illustrate the association of Clovis with mastodon remains. Excavations at Sheridan Cave site in northwest Ohio revealed an association between a single Clovis point and extinct mammalian species. Radiocarbon dating of one (1) of two (2) bone points recovered from the same stratigraphic context as the Clovis point fragment produced a date of 10,915 years BP. Calibrated, this date falls between 12,925 and 13,000 BP (Waters et al. 2009:109), a date that is well within the range for Clovis and the Early Paleoindian sub-phase or period. It is likely that such patterns of faunal exploitation continued into the later phases of the Paleoindian stage, though sites with good contexts are rare to non-existent in the area.

### **3.1.2 Early Archaic Period (10,000 to 8,000 years BP)**

The Early Archaic period was a technological and adaptive continuum from the Paleoindian period. It also marked the advent of a different “stage” of cultural development following the chronological scheme discussed above (Griffin 1967; Willey and Phillips 1958). Across the Eastern United States, projectile point assemblages exhibited a distinctive innovation in lithic technology not found in the earlier Paleoindian periods, the notching of projectile points, a trait that Gardner (1974) argued reflected the spear-thrower used with lances bearing points fixed on detachable shafts mounted on longer shafts or lances. Gardner argued that this may have been linked to the adoption of a throwing technique as opposed to a thrusting technique in hunting behavior, a change that may reflect an adaptation to the procurement of more solitary game species that were present in the changing environmental conditions that began towards the close of the Paleoindian period and accelerated during the onset of the Holocene climatic era and the Early Archaic period. A continuing climatic change post-dating the glacial recession led to the gradual reduction of the mixed open grassland biome and spruce forest characteristic of the Late Pleistocene. This change was coupled with the spread of a mixed deciduous forest biome (Carbone 1974) and in places, particularly in the Southeastern U.S., a more open grassland or savanna type environment.

Development of the deciduous forest probably led to the greater dispersal of game species that were hunted during the Early Archaic period. Following Gardner’s suggestion and based on their extensive work at the Haw River sites in North Carolina, Claggett and Cable (1982) argued that changes in biface technology from the earlier Paleoindian period reflected adaptations to a range of new environments that were the consequence of post-glacial warming trends (Sassaman et al. 1990:9). Such changes are readily seen in the Early Archaic assemblages found in Ohio.

Key projectile points that mark the onset of the Early Archaic period include the classic corner-notched Palmer and Kirk points and their cognate forms (Chapman 1985; Coe 1964; Gardner 1974). In his classic, well-known volume on the Carolina Piedmont, Coe suggested that the corner-notched Palmer point developed from the late Paleoindian Hardaway side-notched types (Coe 1964). Palmer points frequently exhibit basal grinding, a trait found on many Paleoindian specimens. This may represent a carry-over in preparation techniques of the haft prior to mounting the point in a shaft along with other aspects of Early Archaic lithic technology. As noted below, basal grinding was a variable trait and not

necessarily a good chronological indicator (Kimball 1996). Many specimens from West Virginia exhibit heavily ground basal elements, likely tied to techniques of lashing a finished point to a haft.

At the outset of the Early Archaic period, lithic technology saw the continued emphasis on the selection of high quality lithic raw materials employed during the Paleoindian period, especially during the Palmer sub-phase. Such a strong emphasis on the selection and use of cryptocrystalline lithic material for projectile point manufacture could suggest that a continuation of the quarry-base camp settlement model defined by Gardner (1974) and discussed further by Goodyear (1979) was still in use. Such a model may have been tied to mobility patterns related to the procurement of more solitary game species as well. A greater range of lithic raw materials appears to have been employed in the later Kirk phases and certainly by the onset of the Middle Archaic period.

Early Archaic settlement was likely timed to the distribution of faunal and floral resources that were being procured, and thus was distributed across a wider range of environmental zones than had been exploited previously when climatic conditions were different. For instance, to the south in eastern Tennessee, the Early Archaic sites along the Little Tennessee River are diverse in terms of resources exploited and include manos and metates for processing plant subsistence items. Such sites are called by Chapman (1985) “residential base camps” and are thought to mark larger social groups than those represented by small lithic scatters found in upland settings. The greater distribution of Early Archaic sites compared to the known extent and number of Paleoindian sites may reflect an adaptive pattern tied to dispersed or solitary roaming game species that were adapted to the gradually spreading deciduous forest. The greater number of Early Archaic sites is also testament to an increase in population over the Paleoindian period, if overall site density is used as a gross measure of population density.

In many sites, the Early Archaic components found in the larger river drainages, such as those identified by Prufer (1967) in the Scioto River Valley, were obscured by the intensive re-occupation of later Archaic and intense Woodland villages. Single-component residential base camps that yield better-defined Early Archaic diagnostic material have been located along the channels of smaller tributaries that were not used as frequently by later more sedentary Woodland components. The sites located along such smaller drainages have been interpreted as seasonal inland encampments (Pratt 1981). Evidence suggests that seasonal semi-sedentism began to develop around 9,000 BP; the



subsistence and settlement systems were characterized by scheduled exploitation of seasonally available resources and by a high degree of residential mobility within well-defined resource catchment areas (Muller 1986).

### **3.1.3 Middle Archaic Period (8,000 to 5,500 years BP)**

Characteristics that differentiate the Middle from the Early Archaic Period include a tool kit with groundstone grooved axes, bannerstones, bell-shaped pestles, and pendants; a decline in unifacially worked tools; and a shift in subsistence strategy to a heavier reliance on shellfish collecting along major drainages (Griffin 1967; Mayer-Oakes 1955). Numerous sites with Middle Archaic components also were identified during Prufer's (1967) survey of the Scioto and Hocking River valleys. Middle Archaic sites seem to be concentrated along the smaller tributaries.

The three (3) general types of Middle Archaic sites suggested by DeRegnaucourt (1983) are small camps, large camps, and base camps. "Small camps" usually are less than 0.5 hectare (1.24 acres) in area, probably were occupied from one (1) to a few days, and usually occur in upland areas away from streams on elevated ridges near springs. The category of "large camps" incorporates hunting camps, hunting, and butchering camps, and chert quarrying and processing sites. These sites are consistent with encampments of one (1) day to perhaps a week or slightly more; they typically occupy an area of between 0.5 and 2 hectares (1.24 to 4.94 acres). Base camps may be considered to represent the foci of a centrally based transhumance system and probably were occupied seasonally. Base camps range from 0.5 to 8 hectares (1.24 to 19.8 acres) in size and are located on prominent terraces, bluffs, or other elevations near the confluence of two (2) small streams or a small stream and a larger river. The basic projectile point types for the Middle Archaic are the Lecroy Bifurcate (7,500 years BP), the Eva basal notched (7,200 to 6,000 years BP), and the Morrow Mountain (6,700 to 6,400 years BP).

### **3.1.4 Late Archaic Period (3,500 to 1,000 years BP)**

The Late Archaic saw the advent of modern mixed deciduous forest communities throughout the northeastern United States. A hunting, fishing, and gathering economy developed around a seasonal schedule of resource procurement focused on white-tailed deer, nuts, waterfowl, fish, and mussels. Other economic functions and patterns also coincided with the scheduling of resources; bands or

tribes settled either in seasonal base camps or in one (1) semi-sedentary settlement with several satellite procurement stations distributed radially around them (DeRegnaucourt 1986).

In Ohio, six (6) site types occur: villages, camp sites, lithic scatters, find spots, rockshelters, and mortuary sites. The preference for habitation in all categories was for upland localities, particularly at the confluences of drainages, regardless of type of landform. The primary Late Archaic artifact types are the stemmed and notched projectile point forms such as Lamoka, Dustin, Brewerton side-notched, Brewerton corner-notched, Newton Falls side-notched, Susquehanna/Ashtabula, and Narrow stemmed types. Less frequently found are hafted scrapers, knives, drills and perforators, ground stone axes, celts, grooved hammerstones, adzes, and pestles. An extensive bone and antler industry is evidenced by such forms as bone fishhooks, bone awls, bone bodkins, hairpins, atlatl handles, antler points, and flakes, although it is probable that similar industries existed earlier (DeRegnaucourt 1986). Other characteristics of the Late Archaic included the first appearance of ceremonial paraphernalia, and the first real signs of collective cemeteries located away from settlement areas also were established (Penny 1985).

### **3.1.5 Transitional Period (3,000 to 2,000 years BP)**

The Transitional Period can be viewed as a stage during which numerous small societies shared a fundamental cultural package and interacted with mutually influential, more complex neighboring societies (Mason 1981). By 2,600 years BP, however, Early Woodland ceramic technology was firmly established throughout the region, ending the Transitional phase. Transitional sites that include habitation centers and ceremonial mounds are located in a wider variety of ecological settings, including upland terraces along smaller tributary streams (Abrams 1992). This pattern of site distribution seems to reflect a growing Adena influence that was grafted onto an Archaic-style framework of site location preferences. As mound-building became more prevalent, the variation in the ecological settings of sites narrowed, with nearly all sites located on the broad floodplains of major rivers (Abrams 1992).

Several types of projectile points are associated with the Transitional Period. Meadowood points, thin, triangular, well-made bifaces with small side notches, generally are crafted from Onondaga chert. Leimbach stemmed points are ovate based, tapered and straight stemmed bifaces. The other two (2) types are the large Feeheley bifaces, and the various small, micro-regional projectile point types of

which the Crawford Knoll type is the most common in northern Ohio. Cresap points are larger, stemmed bifaces that are believed to be a possible antecedent to later stemmed Adena projectile points (Shane 1967). Other artifacts that are diagnostic of the Transitional Period are stone bowls, birdstones, and smoking pipes (Mason 1981; Stothers and Abel 1993).

### **3.1.6 Early Woodland Period (2,600 to 2,100 years BP)**

Early Woodland in Ohio is defined primarily with reference to the Adena Culture of central and southern Ohio, which in turn is divided into the Early Adena (3,000 to 2,500 years BP), Late Adena (2,500 to 2,100 years BP), and Transitional Adena-Hopewell (2,100 to 1,900 years BP) sub-periods (Greber 1983). Specific Adena traits include: conical mounds located within earthen enclosures or constructed over burned dwellings; sacred circles with interior ditches; log tombs; circular houses with paired posts; and artifacts such as stemmed projectile points (especially the Robbins type), Adena Plain ceramics, expanded center gorgets, tubular tobacco pipes, hematite cones, galena artifacts, mica artifacts, use of ornamental copper, jaw spatulas, scapula awls, tablets with stylistic engravings, and sculpture in the round (Kime 1986).

Early Woodland social organization adopted a hierarchical system that drew together groups on at least three (3) social levels: regional bands, local bands, and band segments. Several types of Early Woodland sites are common throughout the region. Village sites accommodated large groups of more than five (5) households as year-round primary domiciles; they frequently were occupied for more than one (1) year, and they provide evidence of permanent structures. Camps were short-term seasonal occupation sites with structural remains or were used for other special purpose activities. Mortuary sites contain one (1) or more burials in non-mound contexts, as at the Caldwell's Little Bluff Site (Lovejoy 1967). Mounds are earth and stone deposits placed over one (1) or more burials. Earthworks consist of earthen walls arranged in geometric patterns.

### **3.1.7 Middle Woodland Period (2,100 to 1,500 years BP)**

The Middle Woodland has been defined primarily with reference to the Hopewell culture. Ohio Hopewell culture was based primarily in the Ohio and Scioto river valleys and does not appear to extend in northern Ohio (Bush 1978). The Hopewell cultural phenomenon is defined by the exchange of rare ritual items rather than by local phases. Sizable populations were present, but truly large-scale agriculture was not practiced. Hopewell sites elaborated on Early Woodland models; their larger



earthworks and richer burials suggest intensified ceremonialism and greater social inequality. Specific Hopewell traits include enclosure, burial, and effigy mounds and earthworks; distinctive dentate-stamped and rocker-stamped ceramic vessels; platform pipes; cut animal jaws and teeth; pan pipes; extensive villages located near water sources; and widespread long-distance exchange networks (Fitting 1978).

Maslowski and Seeman (1992) identified five (5) ecological zones for Hopewell habitation, including stream channel, flood zone, Wisconsin terraces, Illinoian terraces, and uplands. The primary Hopewell settlement pattern consisted of small farmsteads scattered around ceremonial centers (Fitting 1978), although the exact relationship between these two (2) types of sites is still debated (Dancey and Pacheco 1997). Mound sites have been interpreted as communal hubs of trade, redistribution, and shared ceremonial events (Dancey and Pacheco 1997).

### **3.1.8 Late Woodland Period (1,500 to 800 years BP)**

The Late Woodland Period was marked by the gradual disappearance of Hopewell influences and by a gradual contraction of the inter-regional exchange of raw materials and finished artifacts (Griffin 1943). In terms of settlement patterning, Dancey (1992), in his comparison of Middle and Late Woodland settlement patterns, noted that the size of Late Woodland habitation sites was 2 to 4 hectares (4.94 to 9.88 acres), a marked increase from the previous average size of 0.6 to 2 hectares (1.48 to 4.94 acres) during the Middle Woodland. The Late Woodland populations inhabited rock shelters in the Allegheny Plateau, floodplains along the Ohio River, and the flat open terrain associated with the glaciated areas of northern Ohio (Prufer and McKenzie 1966).

Projectile point styles from the Late Woodland period in Ohio most often associated with bow and arrow technology are the Jack's Reef Corner Notched, Raccoon Notched, Hamilton, and Levanna types. Thomas (1978) has put forth a quantitative analysis of the relative size of dart and arrow points, and according to his data only Madison triangular points (1,100 to 500 years BP) qualify as true arrow points. Dates associated with Madison points may demonstrate a widespread acceptance of bow and arrow technology, with a "trial use" period from 1,400 to 1,200 BP, marked by some of the most pronounced changes in projectile point morphology in the Woodland period (Seeman 1992).

### **3.1.9 Late Prehistoric Period (800 to 350 years BP)**

The Late Prehistoric period within the Muskingum drainage is represented by the Philo phase. The groups associated with the Philo phase shared traits with the Monongahela culture of eastern Ohio and Pennsylvania, and with Fort Ancient groups to the south (Carskadden and Morton 1977). To the west along the Scioto River were Fort Ancient groups. Both the Fort Ancient and Philo groups exhibit patterns of procurement and settlement patterns different from those of their Late Woodland predecessors. The Fort Ancient subsistence economy was centered around maize agriculture, with some growing of beans and squash. Both hunting and gathering supplemented the economy (Essenpreis 1978). Settlements were occupied year-round and were concentrated along the major rivers. They were typically large, stable villages, often organized around a central plaza. Houses were round, oval, or rectangular (Essenpreis 1978). In some cases, a circular palisade was associated with the village.

The Great Lakes area shows a decreased influence of Fort Ancient or Philo phase characteristics. Settlement patterns tended to be small, dispersed populations that practiced a mixed agricultural and hunter-gatherer economy. Large villages were located on promontories along the main rivers 2.4 km to 32 km (1.5 mi to 20 mi) from Lake Erie and appear to represent summer and early fall occupation. Agriculture was limited to the floodplains and adjacent terraces. During the late fall and winter, these villages were supported by family hunting camps or adjacent promontories with elk and bear hunting and nut collection as the major activities. In the early spring, these villages split into small multi-family groups that occupied camps along the bluffs and beaches at the mouths of rivers or on the shores of Lake Erie, exploiting fish and waterfowl as the major food source (Jackson and Harris 1992). Faunal assemblages from excavated Monongahela and Philo sites indicate extensive exploitation of deer as well as elk and turtle (Brown 1981; Carskadden and Morton 1977). While corn has been found at sites from both cultural groups, it occurs in a lower frequency when compared to Fort Ancient sites.

Around 450 BP, Late Prehistoric groups in western Pennsylvania procured materials which indicate an indirect contact with European settlers (Herbstritt 1983). These materials include wire-wound faceted beads, copper tinklers, and native-manufactured artifacts such as triangular glass and metal pendants made from imported European goods. In contrast to later sites, there is no change in intra-site patterning of subsistence procurement strategy. Recognition of protohistoric sites is based solely on

the occasional occurrence of European trade items (Skinner and Brose 1985). This influx of trade items is documented in the Middle Ohio Valley ca. 350 to 250 BP at two (2) contact period sites in Greenup County, Kentucky (Pollack and Henderson 1983). The difficulty in recognizing these sites, given the limited change in the material culture, undoubtedly has resulted in the lack of proper protohistoric designations. Throughout this period, northeast Ohio was only sparsely populated by transient aboriginal populations, often geographically and culturally displaced from other areas (Jackson and Harris 1992).

## **3.2 Historic Context**

### **3.2.1 Frontier (ca. 1775–1795)**

Until the late eighteenth century, few Euro-Americans had settled in Ohio. Those who were in Ohio either lived in or near Native American villages or were hunter-farmers. During the Revolutionary War, squatters from western Pennsylvania and Virginia began occupying land in what would become eastern Ohio. By 1779, there were clearances along the Ohio River as far south as the Muskingum River. In 1785, there were approximately 300 families at the falls of the Hocking River, 300 along the Muskingum River, and 1,500 along the Miami and the Scioto rivers (Jones 1983). These small settlements would have been rather perilous because they were not welcomed by the Native Americans, nor were these settlements sanctioned by the United States government. The descendants of these first migrants to Ohio probably formed the core of native-born Ohioans in northeast Ohio.

### **3.2.2 Settlement (1796–1819)**

The Treaty of Greenville, signed August 3, 1795, was the impetus for rapid settlement of Ohio. Previously, Ohio pioneers, like pioneers of New England, had settled in defensible nucleated groups with in-lots and out-lots for mutual protection. Following the conflicts with Native Americans during 1794 and the establishment of the Greenville Treaty line in 1795, much of modern day Ohio was subsumed into the newly formed United States became safer for isolated farms in these regions (Bond 1941).

Migrants to Ohio at first gravitated toward the Virginia Military District, the Symmes Purchase, and the Ohio Company Purchase. These areas were held privately and were already open for settlement. The



Survey of the Seven Ranges (1785–1786) and the Connecticut Western Reserve greatly increased the available land (Bond 1941). Settlement of Northeast Ohio was essentially the result of migration from Mid-Atlantic states, especially Pennsylvania and Maryland. Settlers from this area moved westward, crossing the Ohio River, and following its tributaries, or early traces, inland.

Most migrants were farmers seeking fertile farmland in the new frontier. Their livelihood depended on livestock raising and grain production, particularly wheat (Wilhelm 1982). Although new settlers, out of necessity, were self-sufficient, they still had to trade for basic supplies such as coffee, tea, salt, sugar, hardware, farm implements, and cloth. The average settler cleared only 2.47 acres of land per year. Generally, the early farmer only put a small portion of land (about 9.88 acres) for crops under the plow and reserved plenty for pasture for animals and forest for firewood and livestock, usually pigs. However, to produce much more than his family needed would have been pointless as roads were not adequate to get their goods to market. Any surplus produce was used to trade for supplies or was distilled (Heald 1949; Noble and Wilhelm 1995).

The land comprising northeast Ohio was not ceded to the United States until the early nineteenth century through a succession of land treaties. The former Native American trails through the region aided in establishing frontier settlements (Blue 1928). The region's counties, known for their rich, agricultural lands, became great wheat producers and, by 1815, were the center of an exclusively sheep-raising, agricultural region (Howe 1902). Coal-mining activity in the region has a history extending back to 1806. Ten (10) years later, coal was the chief source of fuel in these counties (Perrin 1881).

### **3.2.3 Immigration**

Little immigration occurred in the first decade-and-a-half of the nineteenth century, due to the disturbance of shipping caused by the Napoleonic Wars and the War of 1812. After peace was achieved by 1815, transatlantic shipping resumed. With a change in European land policies of the nineteenth century, emigration was also encouraged or viewed as the only viable option by European peasants (Wilhelm 1982).

Immigrants from Ireland, Scotland, and Germany left their homelands due in part to changing land policies. When the potato crops failed, most notably in Scotland in 1846 and in Ireland ca. 1830 to

1845, there was a massive wave of emigration from those countries. Many Germans left their homeland after the failed Revolution of 1848. These nineteenth-century German immigrants often joined and reinforced the cultural ways of the westward-moving Pennsylvania Dutch, descendants of eighteenth-century German immigrants (Wilhelm 1982).

Diverse social, economic, political, and material traits became established in northeast Ohio because of the varying cultural backgrounds of the migrants. Since the major migrant groups became geographically distinct during settlement and did not overlap greatly, their respective cultural influences remained relatively unchanged and persistent, providing the basis of the region's cultural differentiation of today (Wilhelm 1982).

The 1850 census of Ohio is a good indicator of the ethnic and regional composition of the state in the middle of the nineteenth century, after the initial settlement and predominantly western European immigration, and before the largely eastern European immigration in the late nineteenth and early twentieth centuries (Wilhelm 1982). All of these groups probably shared a similar cultural background, that of Germanic/Pennsylvania Dutch. Judging by the sheer number of Pennsylvanian migrants, the Marylanders were probably from parts of Maryland strongly influenced and dominated by Pennsylvania culture. Likewise, the number of German immigrants indicates that the French were probably from parts of France strongly influenced and dominated by Germanic culture. Thus, a Germanic influence would be expected to dominate much of northeast Ohio due to the sheer numbers of the migrants from the Pennsylvania sphere, combined with the immigrants from the German sphere.

### **3.2.4 The Industrial Period (ca. 1850–1930)**

An investment in infrastructure complemented Ohio's central location and put it at the heart of the nation's transportation system traveling north, south, east, and west, and also gave northeast Ohio a head start during the national industrialization process which occurred during this period. By the late 1810s, the National Road crossed the Appalachian Mountains, connecting the region with the east coast. The Ohio River aided the agricultural economy by allowing farmers to move their goods by water to the southern states and the port of New Orleans. The construction of the Erie Canal in the 1820s allowed businesses to ship their goods through Lake Erie and to the east coast, which was followed by the completion of the Ohio and Erie Canal and the connection of Lake Erie with the Ohio

River. This gave the region complete water access to the world within the borders of the United States. The Ohio Loan Law of 1837 allowed the state to loan one-third of construction costs to businesses, passed initially to aid the construction of canals, but instead used heavily for the construction of railroads. The Baltimore and Ohio Railroad crossed the Appalachians in the mid-1850s and connected the state with the east coast (Heald 1949).

Wooster, in Wayne County, was one (1) such city which benefited from its proximity to transportation resources, first from the construction of the Ohio and Erie Canal in 1827, followed by the development of the Ohio & Pennsylvania Railroad in the 1850s, and eventually the construction of the Lincoln highway through Wooster in the early twentieth century. The varied transportation routes developed through this period allowed the export of regionally produced goods and materials but also attracted the development of supporting commerce and industry into the region. With the emergence of a successful and growing industrial base in the region, the need for workers was high and the increase in population created a need for more housing (Heald 1949).

### **3.2.5 Mid-Twentieth Century (1930–1960)**

From the time Ohio attained statehood in 1803, the state's ready access to raw materials and navigable waterways at its northern and southern boundaries offered industrious entrepreneurs the opportunity for profit. With an abundance of coal and iron ore, industrialists throughout the state erected iron works for the production of pig iron. The Mahoning Valley, in northeast Ohio, developed into a significant iron smelting area. The iron industry in turn facilitated development of a large steel industry, with Youngstown in the Mahoning Valley arising as one of the most prominent steel towns in the country (Hunker 1958).

During World War II, the region experienced significant industrial development and population growth. The state's diversified industrial base and geographical proximity to transportation routes and other population centers made it well suited for wartime production needs. The industrial development and consequential economic prosperity generated during World War II shaped the region's economic, cultural, and social history for decades thereafter.

As the development of paved roads and automobiles accompanied this industrial development, demographic trends shifted from population increases in the cities at the expense of the countryside,



to the opposite trend. The population of both the county and cities continued to grow, but the population living in the cities dropped to 59 percent, meaning the non-city population grew more quickly than the city population by that time. The suburban areas by 1958 had more residents than any single city in the region. Early suburban development in the post-World War I period had focused on subdivisions for the wealthy. In the post-World War II period, suburban living for city workers became the rule rather than the exception (Heald 1958).

The agricultural sector of the region's economy also benefitted from wartime expansion and demand. Northeast Ohio farmers worked within a constantly changing dynamic that involved weather, market forces, and technological developments. A farmer's success often depended on his or her acumen at correctly assessing both current events and future trends. At the onset of World War II, the region's farmers faced numerous difficult challenges, many of which had been brewing for more than two (2) decades. Small and family farms met additional obstacles as most federal government programs were tailored toward consolidating farms and meeting the needs of large farmers. The resultant industrialization of agriculture that began during this period continued through the remainder of the twentieth century (Hunker 1958).

### **3.2.6 Late-Twentieth and Early-Twenty-First Centuries (1960-present day)**

Wayne County has maintained its rural character into the twentieth century. The county serves as the leading dairy producing county in Ohio and is home to the Ohio Agricultural Research and Development Center, the country's largest ag-biosciences research facility. The primary employers within the county are involved in manufacturing with major companies such as the Wooster Brush Company, ArtiFlex, Schaeffler Group USA Inc. and The J.M. Smucker Company. Wayne County is also home to Wooster College, the University of Akron-Wayne Campus, and the Ohio State University College of Food Sciences which support numerous jobs in education and health services.

## 4.0 Methodology

### 4.1 Background Research Methods

Preliminary research was initiated by reviewing the archaeological and historical architecture files and relevant cultural resource management reports using cultural resources data provided by the OHPO. Previously recorded cultural resources within 1.6 km (1 mile) (Desktop Study Area [DSA]) of the Project were identified and mapped. A list of the sources consulted includes the following:

- OHPO Online Mapping website;
- NRHP files;
- Ohio Historic Inventory files;
- Ohio Historic Bridge Inventory files;
- Ohio Genealogical Society Cemetery files;
- Ohio Archaeological Inventory (OAI) files;
- *Mills' Archaeological Atlas of Ohio* (1914);
- Cultural Resource Management reports;
- County atlases and plat maps;
- United States Geological Survey (USGS) 15' and 7.5' quadrangle maps; and
- Recent and historical aerial photographs.

Additional research was undertaken to develop prehistoric, historic, and environmental contexts. The cultural contexts included an assessment of the prehistory and history of the area and formed the foundation required for the interpretation and evaluation of archaeological sites identified during field investigations. Environmental research focused on aspects of local geology, soils, hydrology, geomorphology, vegetation, and recent natural and/or cultural disturbances to the Survey Area. Existing data and preliminary background research gathered during earlier studies were incorporated and utilized as appropriate to develop a predictive model that would guide fieldwork.

### 4.2 Field Methods

Surface visibility within the Survey Area did not meet the minimum threshold to conduct pedestrian survey. Subsurface investigations were completed through the excavation of shovel test pits (STPs). STPs were placed in a linear transect in 15-m (49.2-ft) intervals. As the transect followed an existing pipeline, STPs were offset as needed based on location of the previous disturbance. When historic alluvium lacking archaeological context was encountered near Apple Creek, testing intervals were extended to 30-m (98.4-ft). Each STP measured 50 x 50 centimeters (cm) (20 x 20 inches [in]) and was excavated to 80 cm (31.5 in) below surface or 10 cm (3.9 in) into sterile subsoil. The use of auger tests

(AT) was implemented judgmentally at the discretion of the Principal Investigator/Geomorphologist in the portions of the Survey Area mapped within alluvial soils. To determine the vertical extent of alluvial deposition within the Survey Area, a 10.2 cm (4-in) bucket auger was placed in the base of select STPs and excavated until reaching channel lag.

Excavated soils were sifted through ¼-inch hardware cloth. Where feasible, STPs were excavated by stratigraphic level and a description of each STP was recorded in the field on standardized forms. The description included the location of the STP within the sampling grid, and information pertaining to the local terrain, color, texture, composition, and thickness of soil strata as well as the presence or absence of cultural materials. After excavation and recordation STPs were backfilled. When artifacts were recovered, radial STPs were placed in cardinal directions at 5-m (16.4-ft) intervals surrounding the positive STP. Excavation of radial STPs continued until identifying two (2) consecutive negative STPs, disturbance, or the boundary of the Survey Area. The location of each STP and supporting field documentation was collected utilizing a handheld tablet running ESRI Field Maps software attached to a global navigation satellite system receiver antenna providing submeter accuracy.

### **4.3 Artifact Analysis and Curation**

Artifacts recovered during the investigation were temporarily stored in 3-milimeter polyethylene bags and tagged with corresponding provenience information. The artifacts were then transported to ECT's Northfield, Ohio laboratory to be cleaned and analyzed. Prehistoric lithics were classified according to type and material. Debitage was identified by raw material and tabulated according to basic debitage type. Following completion of the Project, artifacts will be returned to the landowner.



## 5.0 Results

### 5.1 Results of Background Research

At the time of the investigation, the OHPO Online Mapping System, the digital repository of cultural resources data maintained by the OHPO, was not available for public use. Spatial data for previously recorded cultural resources within the DSA of the Project was provided to ECT by the OHPO in February 2024.

ECT’s review of data provided by the OHPO identified four (4) previously completed Phase I archaeological surveys and one (1) Phase II archaeological site evaluation have been conducted within the DSA (*Previously Recorded Cultural Resources*, **Appendix A, Figure 5; Table 1**). No surveys were identified within the Survey Area though one (1) past survey, OHPO Log 969239, was completed south of Apple Creek, and intersects the Project where it parallels North Hillcrest Drive.

**Table 1. Previously Completed Cultural Resources Surveys within DSA**

OHPO LOG No.	Survey Phase	Year	Author(s)	Report Title
N/A	I	1981	Immel, Elsie A. and Julie Kime	Preliminary Survey of the Proposed Apple Creek Flood Control Project Near Wooster in Wayne County, Ohio
969239	I	1995	Bush, David R. et al.	Phase II Cultural Resource Investigation of the Proposed WAY-30-11.86 Project, Wayne County, Ohio.
969239	II	1997	Kollecker, Mark A., et al.	A Phase I and Phase II Cultural Resource Investigation of the Proposed WAY-30-11.86 Project, Wayne County, Ohio
982151	I	2000	Keener, Craig S.	Phase I Cultural Resource Management Survey of the Proposed 30.3 ha (75 a.) Development in Wooster Township, Wayne County, Ohio
1032144	I	2010	Zink, Justin	Phase I Archaeological Survey for the WAY-County Garage Project (PID 83203) in Wayne Township, Wayne County, Ohio

A total of 46 previously recorded archaeological sites were identified in the DSA (*Previously Recorded Cultural Resources*, **Appendix A, Figure 5; Table 2**). Limited information regarding these sites is included in the spatial data acquired from the OHPO. All of the sites contained a prehistoric component while one (1) site, 33WE0370, contained both a prehistoric and historic component. Fourteen (14) of the sites are recorded as isolated finds, one (1) site, 33WE0029, is recorded as a woodland period mound grouping while the remaining 31 sites are of an unknown type. No NRHP determinations were included in the OHPO spatial data. As a result, the NRHP status for all 46 sites is presently unknown though the isolated finds are assumed to be not eligible for listing in the NRHP. A

review of Mills' *Archaeological Atlas of Ohio* (1914) did not identify any archaeological sites or trails within the DSA.

**Table 2. Previously Recorded Archaeological Sites within the DSA.**

OAI Number	Site Name	Temporal Affiliation	Time Period	Site Type
WE0022	Sylvan Site	Prehistoric	Unassigned Prehistoric	Unknown
WE0028	Sigler Site	Prehistoric	Unassigned Prehistoric	Unknown
WE0029	Sigler Mound Group	Prehistoric	Unassigned Woodland	Mound Group
WE0038	Sigler-Morrison	Prehistoric	Late Archaic, Early Woodland	Unknown
WE0039	Sigler Site II	Prehistoric	Unassigned Prehistoric	Unknown
WE0040	Sigler Site III	Prehistoric	Unassigned Archaic	Unknown
WE0085	Taggart Farm Site	Prehistoric	Unassigned Prehistoric	Unknown
WE0086	N/A	Prehistoric	Unassigned Prehistoric	Unknown
WE0091	N/A	Prehistoric	Unassigned Prehistoric	Unknown
WE0271	N/A	Prehistoric	Unassigned Prehistoric	Isolated Find
WE0272	N/A	Prehistoric	Unassigned Prehistoric	Unknown
WE0273	N/A	Prehistoric	Unassigned Prehistoric	Unknown
WE0274	N/A	Prehistoric	Unassigned Woodland	Isolated Find
WE0275	N/A	Prehistoric	Unassigned Prehistoric	Unknown
WE0276	N/A	Prehistoric	Unassigned Prehistoric	Isolated Find
WE0277	N/A	Prehistoric	Unassigned Prehistoric	Unknown
WE0278	N/A	Prehistoric	Unassigned Prehistoric	Unknown
WE0279	N/A	Prehistoric	Unassigned Prehistoric	Isolated Find
WE0280	N/A	Prehistoric	Unassigned Prehistoric	Isolated Find
WE0281	N/A	Prehistoric	Unassigned Prehistoric	Unknown
WE0282	N/A	Prehistoric	Unassigned Prehistoric	Unknown
WE0287	N/A	Prehistoric	Unassigned Woodland	Unknown
WE0370	N/A	Prehistoric and Historic	Unassigned Prehistoric and Unassigned Historic	Unknown
WE0371	N/A	Prehistoric	Unassigned Prehistoric	Isolated Find
WE0372	N/A	Prehistoric	Unassigned Prehistoric	Isolated Find
WE0373	N/A	Prehistoric	Unassigned Prehistoric	Unknown
WE0374	N/A	Prehistoric	Unassigned Prehistoric	Unknown
WE0375	N/A	Prehistoric	Unassigned Prehistoric	Unknown
WE0376	N/A	Prehistoric	Unassigned Prehistoric	Unknown
WE0377	N/A	Prehistoric	Unassigned Prehistoric	Isolated Find
WE0378	N/A	Prehistoric	Unassigned Prehistoric	Unknown
WE0379	N/A	Prehistoric	Unassigned Prehistoric	Unknown
WE0448	N/A	Prehistoric	Unassigned Prehistoric	Unknown

OAI Number	Site Name	Temporal Affiliation	Time Period	Site Type
WE0449	N/A	Prehistoric	Unassigned Prehistoric	Isolated Find
WE0450	N/A	Prehistoric	Unassigned Prehistoric	Isolated Find
WE0451	N/A	Prehistoric	Unassigned Prehistoric	Unknown
WE0452	N/A	Prehistoric	Unassigned Archaic	Unknown
WE0468	N/A	Prehistoric	Unassigned Prehistoric	Unknown
WE0472	N/A	Prehistoric	Unassigned Prehistoric	Isolated Find
WE0473	N/A	Prehistoric	Unassigned Prehistoric	Isolated Find
WE0474	N/A	Prehistoric	Unassigned Prehistoric	Isolated Find
WE0475	N/A	Prehistoric	Unassigned Prehistoric	Unknown
WE0476	N/A	Prehistoric	Unassigned Prehistoric	Unknown
WE0477	N/A	Prehistoric	Unassigned Prehistoric	Unknown
WE0546	N/A	Prehistoric	Unassigned Prehistoric	Unknown
WE0547	N/A	Prehistoric	Unassigned Prehistoric	Isolated Find

As noted in the introduction to this report, site 33WE0085, the Taggart Farm site, intersects the Project on the north side of Apple Creek. The original site form indicates site 33WE0085 was originally identified through excavations by the landowner, D.W. Taggart, in 1960 though was not recorded with the OHPO until 1979. The form reports that Taggart uncovered charcoal, fire-cracked rock (FCR), chert debitage, and tools from the T2 and T3 terrace north of Apple Creek but the location of the site was not field checked. The site boundary as depicted in the site form encompasses an approximately 32-acre area north of Apple Creek on both sides of South Geyer Chapel Road (*Previously Recorded Cultural Resources, Appendix A, Figure 5*). The boundary is described in the OHPO data as highly problematic, and the extent of the site is approximate and unknown.

ECT identified 13 previously recorded above ground resources in the DSA (*Previously Recorded Cultural Resources, Appendix A, Figure 5, Table 3*). These resources consist of mostly single dwellings constructed between 1820 and 1960 but also include commercial and agricultural properties. No NRHP determinations were included in the spatial data provided by the OHPO for any of the above ground historic resources.

**Table 3. Previously Recorded Above Ground Resources in the DSA.**

OHPO No.	Name	Address	Date of Construction	Historic Use
WAY0006913	Jacob Kramer House	SW of US 30 & Honeytown Rd intersection	1840	Single Dwelling



OHPO No.	Name	Address	Date of Construction	Historic Use
WAY0025213	Lincoln Way East	3242 US 30	1920	Hotel/Inn/Motel/ Apartment House
WAY0029213	Weimer House	4752 US 30	1920	Single Dwelling
WAY0029313	N/A	4727 US 30	1890	Single Dwelling
WAY0029413	Abie Sigler	434 N Honeytown Rd	1960	Single Dwelling
WAY0029513	S Baker Farmstead	512 N Honeytown Rd	1830	Single Dwelling
WAY0029613	N/A	184 Geyer's Chapel Rd	1920	Single Dwelling
WAY0029713	Warren Sigler House/Samuel Rult Farmstead	314 N Geyer's Chapel Rd	1870	Single Dwelling/Agricultural
WAY0029913	N/A	147 Hillcrest Rd	1910	Single Dwelling
WAY0030013	William Pearce House/Riffel Dairy Farm	2795 Varian Rd	1840	Single Dwelling
WAY0030113	Wayne Holmes Heating & Refriger/Wertz/ Varian Orchard	2626 Varian Rd	1920	Food Storage/Commercial
WAY0030213	Gerald Eyster House	1853 Sylvan Rd	1870	Single Dwelling
WAY0030313	N/A	1571 Sylvan Rd	1900	Single Dwelling

## 5.2 Results of Fieldwork

Fieldwork was completed in late January and early February 2024 under seasonal conditions. The Survey Area extended across approximately 2.27 acres consisting of open agricultural field and forested wetlands along the north bank of Apple Creek (**Appendix B, Photos 1 and 2**). A total of 45 STPs, inclusive of 28 primary STPs and 17 radials STPs (*Results of Phase I Archaeological Survey, Appendix A, Figure 6*), were excavated during the investigation resulting in the recovery of four (4) artifacts and one (1) possible cultural feature.

The center of the proposed LOD is disturbed from the installation of the existing pipeline. Soil profiles encountered in STPs excavated during the investigation displayed variable rates of disturbance and a high degree of irregularity across the Survey Area based on the proximity to Apple Creek. The Apple Creek stream valley near the Survey Area is bounded to the south by a resistant ridge that rises approximately 9-m (29.5-ft) above Apple Creek (**Appendix B, Photo 3**) while the northern edge of the stream valley roughly follows the 920-ft contour line on the USGS topographic map (*USGS Topographic*

*Map, Appendix A, Figure 1*). This northern boundary is visible in aerial imagery as a faint scar across the open field and was noted in the field by the presence of a seep emerging from the bedding plane of shallowly buried sedimentary rock just north of the Survey Area (*Alluvial Terraces on 1960 Aerial Photograph, Appendix A, Figure 7*). From the active channel north towards the seep that marks the boundary between alluvial soils and the residual soils of the upland, a series of terraces becoming higher and older with distance from the active channel are visible as slight topographic rises. The T(0) terrace (active floodway) lies approximate 1.8 m (6 ft) above the pool level of the stream (**Appendix B, Photo 4**). Two (2) higher older terraces designated T(1) and T(2) are depicted in **Appendix A, Figure 7** and can be seen in **Appendix B, Photo 5**.

The alluvial deposits documented in the shovel tests indicate the stream channel has migrated laterally in a meandering fashion from the bedrock seep to its present position entrenched against the resistant ridge to the south. The lateral migration of the stream left behind a sheet of channel deposits that were too heavy to be moved in the stream's suspended load. These deposits referred to as channel lag consist of a sheet of water rounded gravel punctuated by gravel bars of varied heights and configurations. These lateral deposits were later covered with finer overbank flood deposits of sands and silt that emanated from the stream in its current position thus forming the current terraced topography.

STPs 1 through 4, between South Geyers Chapel Road and the edge of the Apple Creek floodplain, contained residual soils consistent with those mapped as Bogart Loam. Soil profiles in these STPs typically consisted of a grayish brown to brown (10YR 5/2 to 10YR 5/3) silt loam plowzone (Ap-horizon) underlain by a yellowish brown (10YR 5/6) to brownish yellow (10YR 6/6) Bt-horizon which in turn was underlain by a silt loam Cg horizon (Gley 1 3/N). STP 2 is representative (**Appendix C, Figure 1**).

STPs 5 through 17 were centrally located within the Survey Area across the T(1) and T(2) terraces north of Apple Creek and exhibited soils profiles exhibiting characteristics consistent with both the Lobdell and Tioga series soils mapped for the area. However, significant variability in the depth and continuity of the soils across the landform indicates the alluvial deposits underlying the T(1) and T(2) terraces are the product of the lateral migration of Apple Creek across the valley bottom, and that intact archaeological contexts are only found as discontinuous pockets. STPs 5 and 6 to the northeast and 10, 12, and 14 to the southwest exhibited a sequence of Ap/Bw1/Bw2-BC/C to depths extending up to

137 cm (38.2 and 53.9 in) below surface (**Appendix C, Figure 2**). Shallow gravel bars were identified on the north side of the existing pipeline in STP 8, its corresponding radials, and in STPs 15, 16, and 17 (**Appendix C, Figures 3, 4, and 5**). These STPs exhibited a soil profile consisting of a brown (10YR 3/3) silt loam Ap-horizon at depths between 20 and 40 cm (7.9 and in) below surface directly over channel lag or were underlain by a thin, dark yellowish brown (10YR 3/6) sandy loam BC horizon before reaching channel lag.

Soils identified on the T(1) terrace are best exhibited in STP 11 E5 where a dark brown (10YR 3/3) silt loam plowzone was identified above a dark yellowish brown (10YR 4/6) fine silt loam Bw-horizon. The Bw-horizon was underlain by a very dark gray (Gley 1 3/N) very fine sandy loam before reaching channel lag approximately 103 cm (40.5 in) below surface (**Appendix C, Figure 6**). The existing pipeline trench was identified in STP 11 N5 (**Appendix C, Figure 7**)

STP 22 marks the break between the T(1) terrace and the T(0) terrace. The profile in this STP exhibited an overburden composed of an admixture of dark brown (10YR 3/3) silt clay loam, a pale brown (10YR 5/4) silt loam, and a reddish brown (5YR 5/4) sandy loam overlying interfingering AC and Cg horizons. The AC-horizon consisted of a very dark grayish brown (2.5Y 3/2) massive sand while the Cg-horizon consisted of a dark gray (Gley 1 4/1) plastic sandy loam overlying channel lag at 114 cm (44.9 in) below surface (**Appendix C, Figure 8**)

STPs 18 through 21 and 24 through 28 were excavated in the forested areas along the T(0) and T(1) terraces north of Apple Creek and exhibited a layer of historical alluvium over channel lag. The historic alluvium was characterized as series of stacked C/AC horizons between the surface and the underlying channel lag (**Appendix C, Figure 9**). Occasional modern materials such as wire nails and beer bottles were noted in the historic alluvium but were discarded in the field.

#### **Site WE0085**

Two (2) primary STPs, 8 and 11, were positive for prehistoric cultural material within the Survey Area at site 33WE0085 (*Results of Phase I Archaeological Survey, Appendix A, Figure 6*). A single chert flake fragment was recovered from the plowzone of STP 8 on the north side of the existing pipeline. Radial excavations around STP 8 recovered one (1) tertiary chert flake and one (1) additional chert flake fragment from the plowzone of STPs 8 E5 and 8 E5N5 (**Appendix B, Photo 6**). The positive STPs were



bounded by double negative radials to the north and west and by the disturbance from the existing pipeline to the south and east (*Results of Phase I Archaeological Survey, Appendix A, Figure 6*).

STP 11 was excavated on the south side of the existing pipeline approximately 35 m (114.8 ft) southwest of STP 8 (*Results of Phase I Archaeological Survey, Appendix A, Figure 6*). A concentration of charcoal surrounded by darkened soil and fragments of FCR was uncovered at the interface of the plowzone and the underlying Bw-horizon at 27 cm (10.6 in) below surface (**Appendix B, Photo 7**). A chert core fragment/possible scraper was also recovered at the interface (**Appendix B, Photo 8**). The soil anomaly was not excavated and was reburied so as not to disturb a potential cultural feature. At this time, it is not presently clear if the anomaly is cultural in origin, but its presence is consistent with the site documentation indicating charcoal, FCR, and chert debitage were originally recovered at the site. Radial STPs excavated at 5 and 10 m (16.4 and 32.8 ft) intervals in cardinal directions around STP 11 did not recover additional cultural material or evidence of other potential cultural features (**Appendix A, Figure 6**). The existing pipeline trench was located in radial STP 11 N5, 5 m (16.4 ft) north of the potential feature.

The results of the investigation indicate the floodplain north of Apple Creek exhibited a high degree of variability within the soil profiles suggesting the lateral migration of Apple Creek across the valley floor, which combined with the disturbance from the existing pipeline, limits the potential for intact archaeological deposits to remain within the Survey Area. Despite this limited potential, one (1) possible cultural feature was identified in STP 11. Given the low density of artifacts and extent of negative shovel testing, the only portion of site 33WE0085 within the Survey Area that retains the potential to contain significant information is the possible feature identified in STP 11. ECT recommends the feature be avoided. If the potential feature cannot be avoided, ECT recommends the anomaly be revisited and be fully exposed and excavated to determine if the charcoal concentration is cultural in origin and to collect additional data (e.g., datable organic material or floral and faunal remains).

DEO has elected to avoid impacts to the potential feature. Temporary construction fencing will be installed and centered on STP 11. The avoidance buffer will extend 10 m (32.8 ft) to the east and west of STP 11 between the existing pipeline trench and the southern boundary of the LOD. No excavation will occur within this avoidance buffer. However, DEO may place timber matting on the ground surface

to allow for equipment to traverse the LOD (*Avoidance Plan, Appendix A, Figure 8*). As the potential feature was identified at the base of the plowzone, approximately 27 cm (10.6 in) below surface, the timber matting will adequately distribute the weight of machinery over the site and avoid impacts to the potential feature.

Given the limited amount of testing conducted within the mapped 32-acre boundary of site 33WE0085, the site cannot presently be evaluated for listing in the NRHP. However, with the avoidance plan implemented, ECT recommends the portions of site 33WE0085 remaining within the Project LOD do not contribute to the site's potential eligibility for listing in the NRHP.

## 6.0 Summary and Recommendations

DEO is proposing to replace a portion of the approximately 1,188.7 m (3,900 ft) of twelve (12)-inch natural gas steel pipeline under DEO's PIR program. The purpose of the program is to replace existing pipe to ensure the safety and reliability of pipeline operations. The PIR 2788 – Apple Creek project (Project) is located in Wooster Township, Wayne County. The Project is being permitted under USACE Nationwide Permit 12 and is subject to review by the Ohio Power Siting Board.

Initial background research for the Project identified one (1) previously recorded archaeological site within the LOD between Apple Creek and South Geyers Chapel Road. Site 33WE0085, the Taggart Farm Site, is a prehistoric site of unknown function that has not been evaluated for listing in the NRHP. Site records indicate the site was initially identified by the landowner in the 1960s but was not recorded until 1979. The site was recorded based on information provided by the landowner but was never field checked. The site boundary as depicted in the site records is approximated and extends across nearly 32 acres of residential and agricultural lands, of which approximately 2.27 acres intersect the LOD.

As the exact location and extent of site 33WE0085 is not presently known, DEO requested ECT conduct a Phase I archaeological survey of the approximately 2.27 acres of site 33WE0085 that intersect the Project (Survey Area). The purpose of the survey is to relocate any portions of site 33WE0085 that may remain intact within the Survey Area and to make recommendations as to the need for further work or avoidance of the site.

The Phase I archaeological survey was conducted in January and February 2024. A total of 45 STPs were excavated within the Survey Area. Shovel testing recovered four (4) prehistoric artifacts and one (1) potential cultural feature within the Survey Area in an area bisected by the existing pipeline. Given the nebulous nature of the original site boundary, it is not clear if the artifacts recovered represent the original location of site 33WE0085 or if the occupation identified during this investigation is one of many possible site locations situated within the approximately 32-acre area mapped as site 33WE0085.



Due to disturbances from the existing pipeline, the limited archaeological context inherent in the channel lag deposits underlying the Study Area resulting from the lateral migration of Apple Creek, the low density of artifacts, and the extent of negative shovel testing, it is ECT's conclusion that the only portion of site 33WE0085 within the Survey Area that retains the potential to contain significant information is the potential feature identified in STP 11. ECT recommends the feature be avoided. If the potential feature cannot be avoided, ECT recommends the potential feature be revisited, fully exposed, and excavated to determine if the charcoal concentration is cultural in origin and to collect any additional data (e.g., artifacts, datable organic material, or floral and faunal remains).

DEO has elected to avoid the potential feature. Temporary construction fencing will be installed encircling STP 11. The avoidance buffer will extend 10 m (32.8 ft) to the east and west of STP 11 between the existing pipeline trench and the southern boundary of the LOD. No excavation will occur within this avoidance buffer. However, DEO may place timber matting on the ground surface to allow for equipment to traverse the LOD (*Avoidance Plan, Appendix A, Figure 8*). As the potential feature was identified at the base of the plowzone, approximately 27 cm (10.6 in) below surface, the timber matting will adequately distribute the weight of machinery over the site and avoid impacts to the potential feature.

Given the limited amount of testing conducted within the mapped 32-acre boundary of site 33WE0085, the site cannot presently be evaluated for listing in the NRHP. However, with the avoidance plan implemented, ECT recommends the portions of site 33WE0085 remaining within the Project LOD do not contribute to the site's potential eligibility for listing in the NRHP.

## 7.0 References Cited

Abrams, Elliot M.

1992 Woodland Settlement Patterns in the Southern Hocking River Valley, Southeastern Ohio. In *Culture Variability in Context: Woodland Settlements of the Mid-Ohio Valley*, edited by Mark F. Seeman, pp. 19–23. Kent State University Press, Kent, Ohio.

Adovasio, J.M., R.C. Carlisle, K.A. Cushman, J. Donahue, J.E. Guilday, W.C. Johnson, K. Lord, P.W. Parmalee, R. Stuckenwrath, and P.W. Wirgman

1985 Paleoenvironmental Reconstruction at Meadowcroft Rockshelter, Washington County Pennsylvania. In *Environmental Extinction: Man in Late Glacial North America*, edited by Jim I. Mead and David J. Meltzer, pp. 73–110. Center for the Study of Early Man, University of Maine, Orono, Maine.

Bartlein, P.J., T. Webb III, and E. Fleri

1984 Holocene Climatic Change in the Northern Midwest: Pollen-Derived Estimates. *Quaternary Research* 22:361–374.

Belknap, Daniel, and John Kraft

1977 Holocene Relative Sea-Level Changes and Coastal Stratigraphic Units on the Northwest Flank of the Baltimore Canyon Trough Geosyncline. *Journal of Sedimentary Petrology* 47:610–629.

Blue, H.F.O.

1928 *History of Stark County, Ohio*. Vol. 1. S.J. Clarke, Chicago, Illinois.

Bond, Beverly W., Jr.

1941 The Foundations of Ohio. In *The History of the State of Ohio*, edited by C. Wittke, 1:pp. 1–507. Ohio State Archaeological and Historical Society, Columbus, Ohio.

Bradstreet, T.E., and R.B. Davis

1975 Mid-Postglacial Environments with Emphasis on Maine. *Arctic Anthropology* 12(2):7–22.

Brockman, S

1998 *Physiographic Regions of Ohio*. ODNR - Division of Geological Survey.

Brown, Jeffery D.

1981 *The Tower Site and Ohio Monongahela*. Research Papers in Archaeology No. 3. Kent State University, Kent, Ohio.

Bush, David R.

1978 *An Assessment of the Cultural Resources for the Proposed Easterly Separated Sewer Area Project, Cuyahoga and Lake Counties, Ohio*. Cleveland Museum of Natural History, Cleveland, Ohio.

Carbone, Victor A.

1974 Environment and Prehistory in the Shenandoah Valley. Unpublished PhD, Catholic University of America, Washington D.C.

Carskadden, Jeff, and Jim Morton

1977 *The Richards Site and the Philo Phase of the Fort Ancient Tradition. Occasional Papers in Muskingum Valley Archaeology 1-9.* Muskingum Valley Archaeological Survey, Zanesville, Ohio.

Chapman, Jefferson

1985 Archaeology and the Archaic Period in the Southern Ridge and Valley Province. In *Structure and Process in Southeastern Archaeology*, edited by Roy S. Dickens and H. Trawick Ward. Alabama.

Clagget, Stephen R., and John S. Cable

1982 *The Haw River Sites: Archaeological Investigations at Two Stratified Sites in the North Carolina Piedmont.* Commonwealth Associates, Inc, Wilmington, North Carolina.

Coe, Joffre

1964 The Formative Cultures of the Carolina Piedmont. In , 54(5):

Dancey, William S.

1992 A Community Model of Ohio Hopewell Settlement. In *Cultural Variability in Context: Woodland Settlements of the Mid-Ohio Valley*, edited by Mark F. Seeman. Kent State University Press, Kent, Ohio.

Dancey, William S., and Paul J. Pacheco

1997 A Community Model of Ohio Hopewell Settlement. In *Ohio Hopewell Community Organization*, edited by William S. Dancey and Paul J. Pacheco. Kent State University Press, Kent, Ohio.

Davis, M.B, R.W. Spear, and L.C.K. Shane

1980 Holocene Climate of New England. *Quaternary Research* 14:240–250.

Delcourt, Hazel R.

1979 Late Quaternary Vegetation History of the Eastern Highland Rim and Adjacent Cumberland Plateau of Tennessee. *Ecological Monographs*:255–280.

Delcourt, Paul A., and Hazel R. Delcourt

1986 Late Quaternary Vegetational Change in the Central Atlantic States. In *The Quaternary of Virginia - A Symposium Volume*, edited by J.N. McDonald and S.O. Bird, pp. 23–35. Commonwealth of Virginia, Charlottesville, Virginia.

DeRegnaucourt, R.

1983 *Middle Archaic (Data Free Zone) Study Unit for All of Ohio. Report to the Ohio Historic Preservation Office, Columbus.*

1986 *Preservation Plan for Late Archaic Study Unit in Northwestern Ohio.* Ohio Historic Preservation Office, Columbus, Ohio.

Eisenberg, Leonard

1978 *Paleo-Indian Settlement Pattern in the Hudson and Delaware River Drainages.* Occasional publications in northeastern anthropology 4. Department of Anthropology, Franklin Pierce College, Rindge, New Hampshire.



Essenpreis, Patricia S.

1978 Fort Ancient Settlement: Differential Response at a Mississippian - Late Woodland Interface. In *Mississippian Settlement Patterns*, edited by B.D. Smith, pp. 143–167. Academic Press, New York.

Fitting, James E.

1978 Regional Cultural Development, 300 B.C. to A.D. 1000. In *Handbook of North American Indians: Northeast, Volume 15*, edited by Bruce Trigger. Smithsonian Institution Press, Washington D.C.

Gardner, William M.

1974 *The Flint Run Paleo Indian Complex: Report on the 1971-1973 Seasons*. 1974 The Flint Run Paleo Indian Complex: Report on the 1971-1973 Seasons. Occasional Publication 1, Department of Anthropology. Catholic University of America, Washington D.C.

Goodyear, A. C.

1979 Hypothesis for the Use of Cryptocrystalline Raw Materials Among Paleo-Indian Groups of North America. *Institute of Archaeology and Anthropology, Columbia* 156. Research Monograph Series.

Graetzer, M.A.

1986 Settlement Patterns and Paleoclimatic Modeling: A Preliminary Study of Data from the Bald Eagle Watershed of Central Pennsylvania. Unpublished Master's Thesis, Pennsylvania State University, University Park.

Greber, N.

1983 *Early-Middle Woodland Study Unit Archeological Resource Plan, Northeast Ohio*. Ohio Historic Preservation Office, Columbus, Ohio.

Griffin, James B.

1943 *The Fort Ancient Aspects: Its Cultural and Chronological Position in Mississippi Valley Archaeology*. University of Michigan Press, Ann Arbor, Michigan.

1967 Eastern North American Archaeology: A Summary. *Science* 156(3772):175–191.

Guilday, J.E., P.W. Parmalee, and H.W. Hamilton

1977 The Clark's Cave Bone Deposit and the Late Pleistocene of the Central Appalachian Mountains of Virginia. *Bulletin of Carnegie Museum of Natural History* No. 2:1–87.

Hansen, Michael C.

1995 The Ice Age in Ohio. Modified from Education Leaflet No. 7 Revised Edition. Ohio Division of Natural Resources.

Heald, Edward Thorton

1949 The Stark County Story as Broadcast over WHBC-FM. Stark County Historical Society.

1958 *The Suburban Era 1917-1958 Volume IV Part 2; Being Scripts 302-370 as broadcast over WHBC-WHBC-FM. Rearranged and edited as a County History with Bibliography and index*. Stark County Historical Society, Canton, Ohio.

Herbstritt, J.T.

1983 *Excavation of Two Monongahela Sites: Late Woodland Gensler (36GR63) and Historic Throckmorton (36GR160)*. NPW Consultants, Inc, Pittsburgh, Pennsylvania.

Howe, H.

1902 *Historical Collections of Ohio, 2 vols.* H. Howe, Cincinnati, Ohio.

Hunker, H.L.

1958 *Industrial Evolution of Columbus, Ohio. Bureau of Business Research Monograph Number 93.* Ohio State University, Columbus, Ohio.

Jackson, Kenneth E., and E. Jean Harris

1992 *Phase I and II Cultural Resources Investigations of Columbia Gas Transmission Corporation's 1.1-Mile Line L Pipeline Replacement Project in Medina County, Ohio.* Gray & Pape, Inc., Cincinnati, Ohio.

Jefferies, Richard W.

2008 *Holocene Hunter-Gatherers of the Lower Ohio River Valley.* University of Alabama Press, Tuscaloosa, Alabama.

Jones, R.L.

1983 *History of Agriculture in Ohio to 1880.* Kent State University Press, Kent, Ohio.

Kimball, Larry R.

1996 Early Archaic Settlement and Technology: Lessons from Tellico. In *The Paleoindian and Early Archaic Southeast*, edited by David G. Anderson and Sassaman, Kenneth E. University of Alabama Press, Tuscaloosa, Alabama.

Kime, J.

1986 *Preservation Plan for Early Woodland Study Unit Drainage A, Western Lake Erie Spatial Unit. Report to the Ohio Historic Preservation Office, Columbus.*

King, J.E.

1980 Post-Pleistocene Vegetational Changes in the Midwestern United States. In *Archaic Prehistory of the Prairie-Plains Border*, edited by A.E. Johnson, pp. 3–11. University of Kansas Publications in Anthropology No. 12, Lawrence, Kansas.

Kovar, A.J.

1965 Pollen Analysis of the Bear Meadows Bog of Central Pennsylvania. *Pennsylvania Academy of Science* 38:16–24.

Lovejoy, Claude O.

1967 Caldwell's Little Bluff: An Unusual Adena Burial Site. In *Studies in Ohio Archeology*, edited by Olaf H. Prufer. Press of Western Reserve University, Cleveland, Ohio.

MacDonald, George F.

1968 *Debert: A Paleo-Indian Site in Central Nova Scotia.* Anthropology Papers. National Museum of Canada, Ottawa.

Maslowski, Robert F., and Mark F. Seeman

1992 Woodland Archeology in the Mid-Ohio Valley: Setting Parameters for Ohio Main Stem/ Tributary Comparisons. In *Cultural Variability in Context: Woodland Settlements of the Mid-Ohio Valley*, edited by Mark F. Seeman. Kent State University Press, Kent, Ohio.

Mason, R. J.

1981 *Great Lakes Archaeology*. Academic Press, New York, New York.

Mayer-Oakes, William J.

1955 *Prehistory of the Upper Ohio Valley: An Introductory Archeological Study*. Annals of the Carnegie Museum, Volume 34, Pittsburgh, Pennsylvania.

Milliman, J., and K. Emery

1968 Sea Levels during the Past 35,000 Years. *Science* 162:1121–1123.

Mills, William C.

1914 *Archeological Atlas of Ohio : showing the distribution of the various classes of prehistoric remains in the state, with a map of the principal Indian trails and towns*. Ohio State Archaeological and Historical Society, Columbus, Ohio.

Muller, Jon

1986 *Archaeology of the Lower Ohio River Valley*. Academic Press, New York.

Noble, Allen G., and Hubert G.H. Wilhelm

1995 *Barns of the Midwest*. Ohio University Press, Athens, Ohio.

Noss, Reed

2023 Southern Great Lakes Forests. One Earth.

OHPO

2022 Archaeology Guidelines. Ohio Historic Preservation Office.

Payne, J.H.

1987 Windy City (154-16): A Paleoindian Lithic Workshop in Northern Maine. Unpublished Master's Thesis, University of Maine, Orono, Maine.

Penny, David W.

1985 The Late Archaic Period. In *Ancient Art of the American Woodland Indians*, edited by David S. Brose, James A. Brown, and David W. Penny, pp. 15–41. Harry N. Abrams, Inc, New York.

Perrin, W.H.

1881 *History of Stark County*. Baskin and Battey, Chicago, Illinois.

Pollack, David, and A. Gwynn Henderson

1983 Contact Period Developments in the Middle Ohio Valley. In . Pittsburgh, Pennsylvania.



Pratt, Michael G.

1981 The Western Basin Tradition: Changing Settlement-Subsistence Adaptation in the Western Lake Erie Basin Region. Unpublished PhD, Case Western Reserve University, Cleveland, Ohio.

Prufer, Olaf H.

1967 The Scioto Valley Archaeological Survey. In *Studies in Ohio Archaeology*, edited by Olaf H. Prufer and Douglas H. MacKenzie. Western Reserve University Press, Cleveland, Ohio.

Prufer, Olaf H., and Douglas H. McKenzie

1966 Peters Cave: Two Woodland Occupations in Ross County, Ohio. *Journal of Science* 66:233–253.

Sassaman, Kenneth E., Mark J. Brooks, Glen T. Hanson, and David T. Anderson

1990 *Native American Prehistory in the Middle Savannah River Valley: Synthesis of Archaeological Investigations on the Savannah River Site, Aiken and Barnwell Counties, South Carolina*. Savannah River Archaeological Research Papers 1. South Carolina Institute of Archaeology and Anthropology, Columbia, South Carolina.

Seeman, Mark F.

1992 The Bow and Arrow, the Intrusive Mound Complex, and Late Woodland Jack's Reef Horizon in the Mid-Ohio Valley. In *Cultural Variability in Context: Woodland Settlements of the Mid-Ohio Valley*, edited by Mark F. Seeman, pp. 41–51. Kent State University Press, Kent, Ohio.

Skinner, Shaune M., and David S. Brose

1985 *RP3 Study Unit, Late Prehistoric and Protohistoric Periods in Northeast Ohio, Study Unit F*. Ohio Historical Society, Columbus, Ohio.

Slucher, E.R., G.E. Swinford, G.E. Larson, and Others

2006 Bedrock geologic map of Ohio: Ohio Division of Geological Survey Map BG-1.

Stothers, David M., and Timothy J. Abel

1993 Archaeological Reflections of the Late Archaic and Early Woodland Time Periods in the Western Lake Erie Region. *Archaeology of Eastern North America* 21:25–109.

Stothers, David M., Timothy J. Abel, and Andrew M. Schneider

2001 Archaeological Perspectives in the Western Lake Erie Basin. In *Archaic Traditions in Ohio & Kentucky Prehistory*, edited by Olaf H. Prufer, Sarah E. Pedde, and Richard S. Meindl. Kent State University Press, Kent, Ohio.

Tankersley, Kenneth B.

1996 Ice Age Hunters and Gatherers. In *Kentucky Archaeology*, edited by R. Barry Lewis, pp. 39–78. The University Press of Kentucky, Lexington, Kentucky.

2008 Three Saylor's: An Appalachian Mountain Clovis Site in Southeastern Kentucky. *Current Research in the Pleistocene* 25:110–112.

Tankersley, Kenneth B., Michael R. Waters, and Thomas Weir Stafford

2009 Clovis and the American Mastodon at Big Bone Lick, Kentucky. *American Antiquity* 74:1–10.

Thomas, D.H.

1978 Arrowheads and Atlatl Darts: How the Stones Got the Shaft. *American Antiquity* 43:461–472.

USDA-NRCS

2024 Web Soil Survey - Web Application.

<https://websoilsurvey.sc.egov.usda.gov/App/HomePage.htm>.

Waters, Michael R., Thomas W. Jr. Stafford, Brian G. Redmond, and Kenneth B. Tankersley

2009 The Age of the Paleoindian Assemblage at Sheriden Cave, Ohio. *American Antiquity* 74:107–111.

Watts, W.A.

1979 Late Quaternary Vegetation of Central Appalachia and the New Jersey Coastal Plain.

*Ecological Monographs* 49:427–469.

1983 Vegetational History of the Eastern United States 25,000 to 10,000 years ago. In *Late Quaternary Environments of the United States Volume I: The Late Pleistocene.*, edited by Stephen C. Porter, pp. 294–310. University of Minnesota Press, Minneapolis, Minnesota.

Wilhelm, Hubert G.H.

1982 *The Origin and Distribution of Settlement Groups: Ohio: 1850*. Self-Published, Athens, Ohio.

Willey, Gordon R., and Phillip Phillips

1958 *Method and Theory in American Archaeology*. University of Chicago Press, Chicago, Illinois.

## Appendix A Background Figures



## Appendix B Photographs



***Photo 1: Overview of Survey Area Facing Southwest***



***Photo 2: Overview of Survey Area Facing Northeast***





***Photo 3: Facing Southeast Showing Bounding Ridge South of Apple Creek, Outside Survey Area***





***Photo 4: Facing North, Showing Edge of T(0) Terrace within Survey Area***





***Photo 5: Facing North, Showing Survey Area and Terrace Risers Across Apple Creek Floodplain***



***Photo 6: Artifacts Recovered from STP 8 and Surrounding Radials***





***Photo 7: Potential Cultural Feature Identified in STP 11***

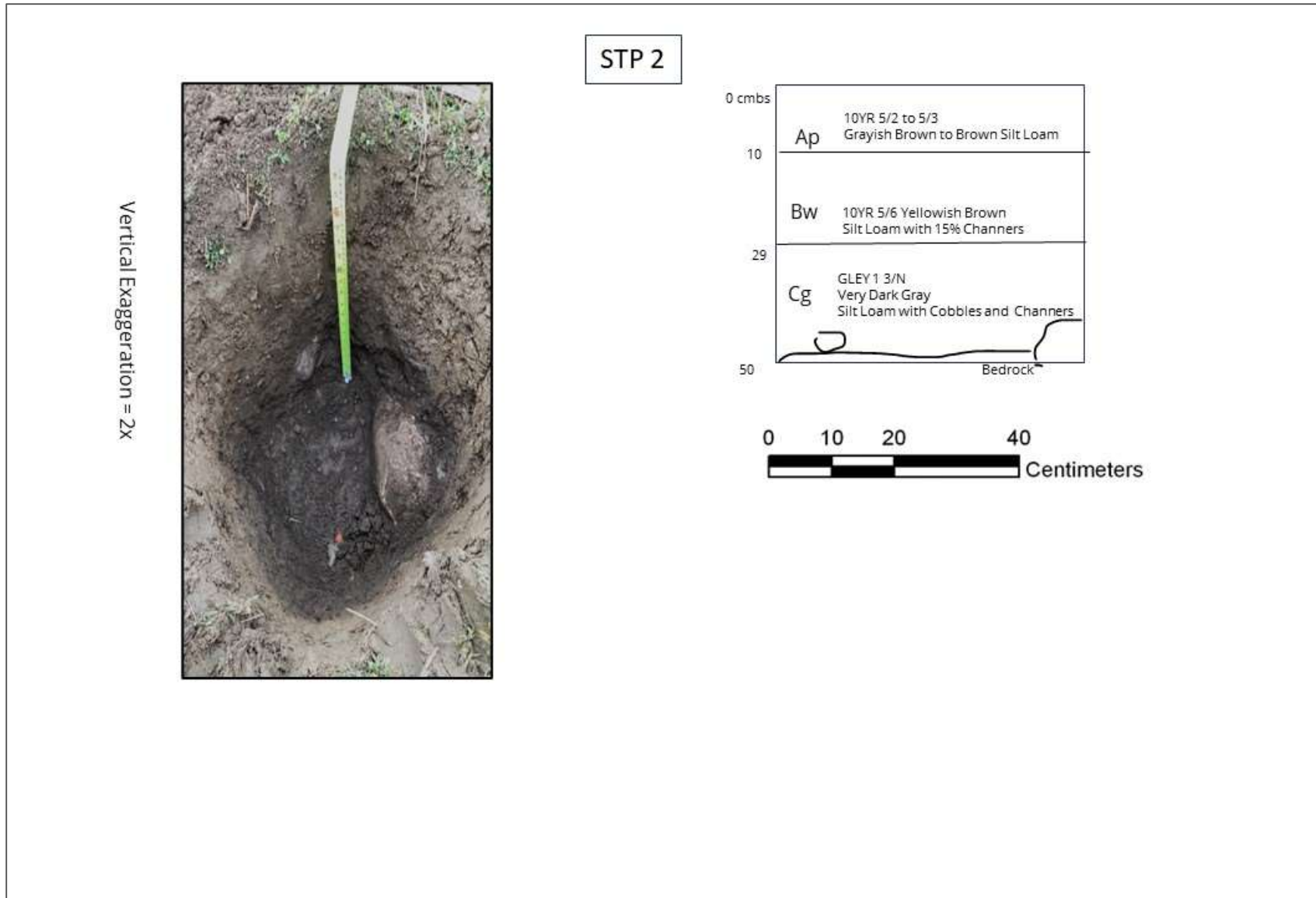




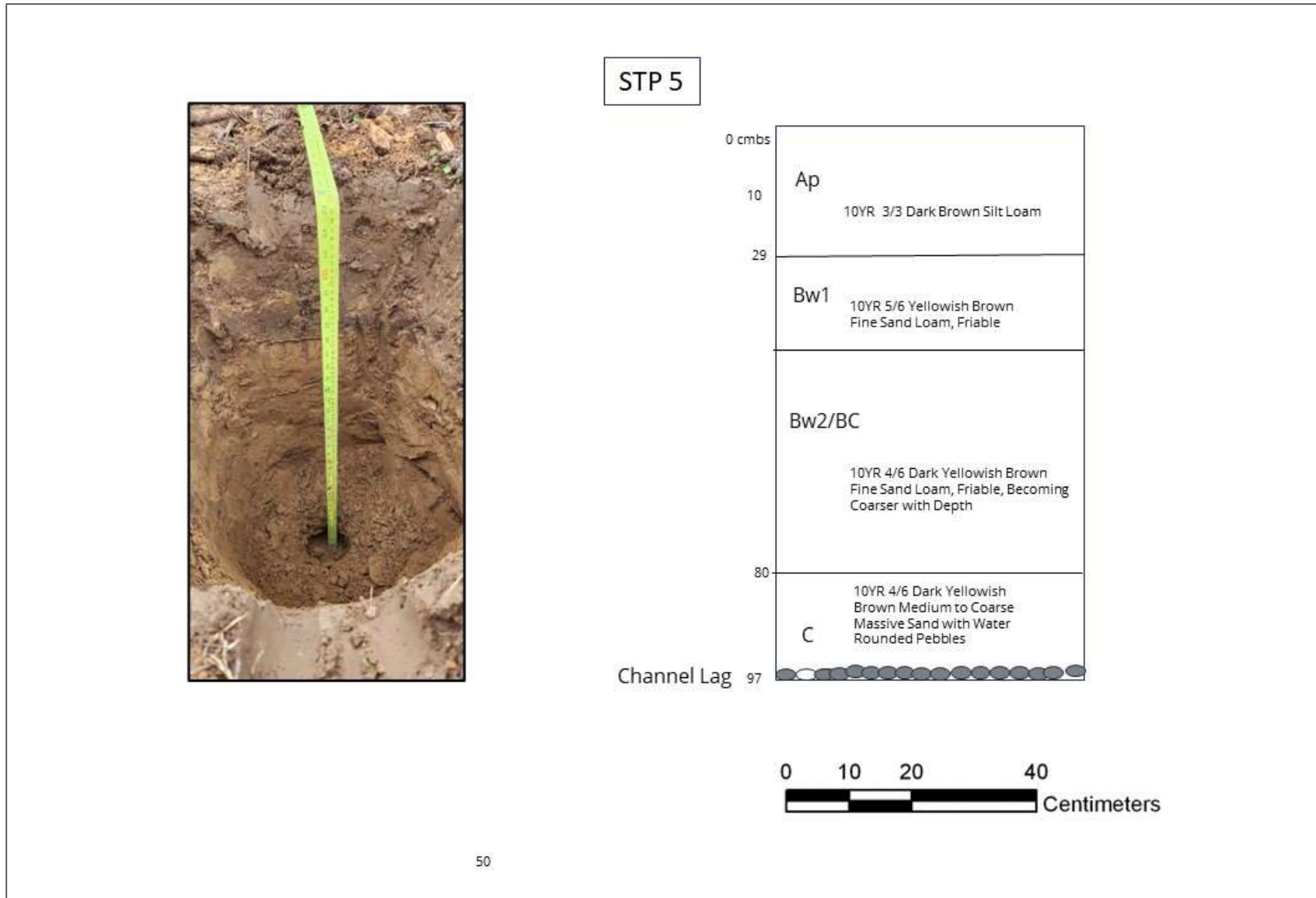
**Photo 8: Core Fragment/Possible Scraper Recovered from STP 11**

## Appendix C Representative Soil Profiles





**Figure 1: Representative Soil Profile from STP 2**



**Figure 2: Representative Soil Profile from STP 5**

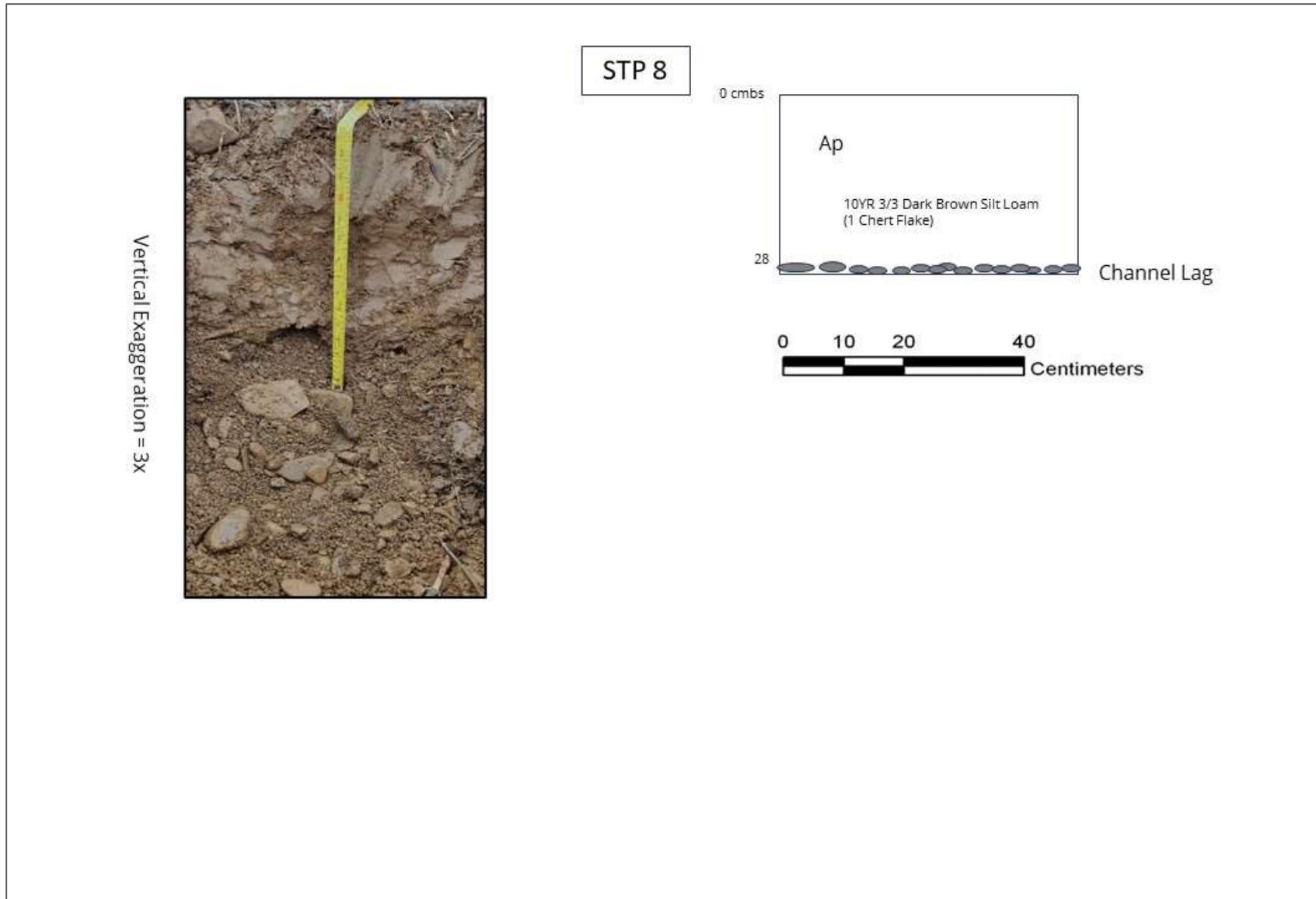
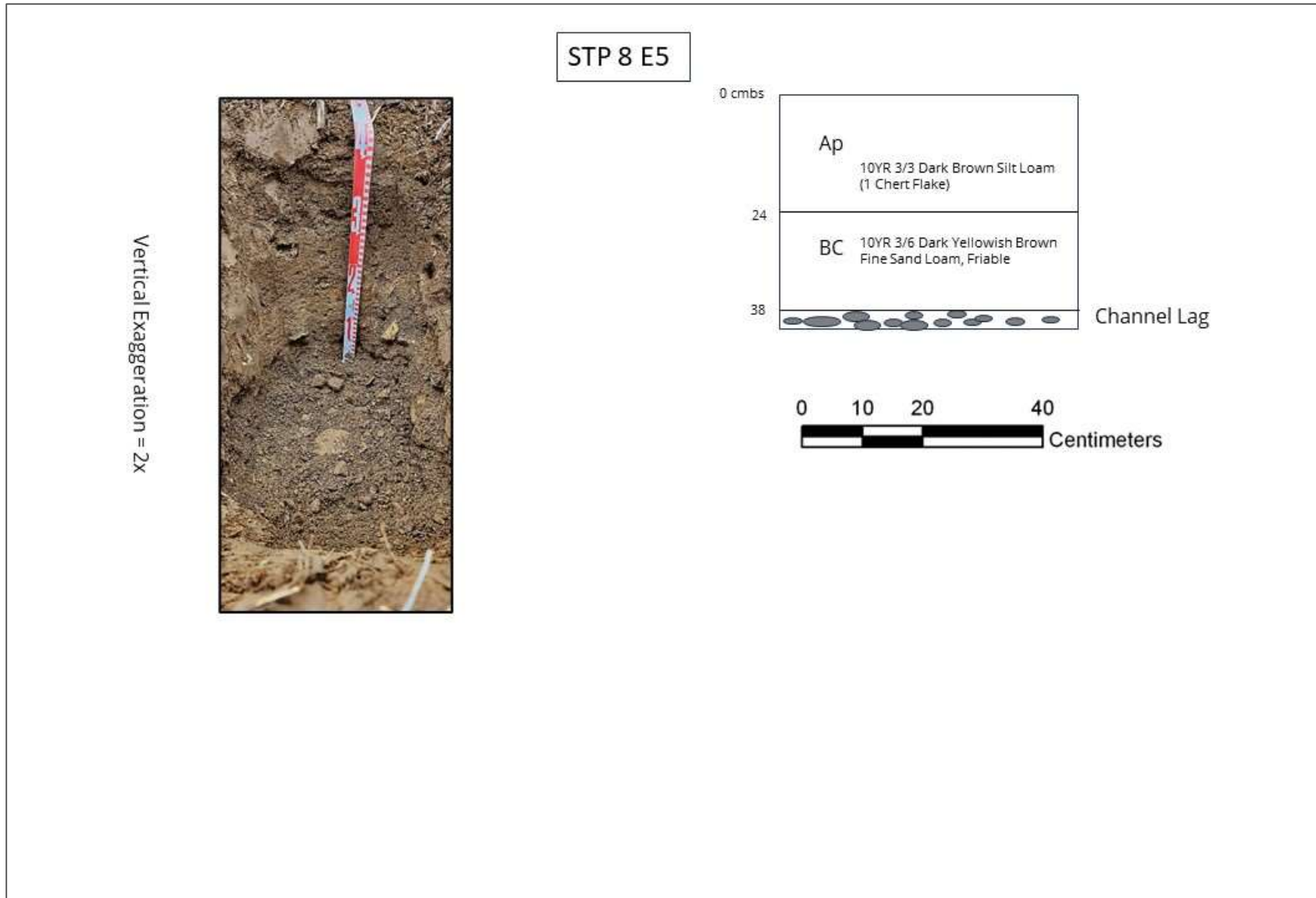


Figure 3: Representative Soil Profile from STP 8





**Figure 4: Representative Soil Profile from STP 8 E5**



Figure 5: Representative Soil Profile from STP 8 E5N5

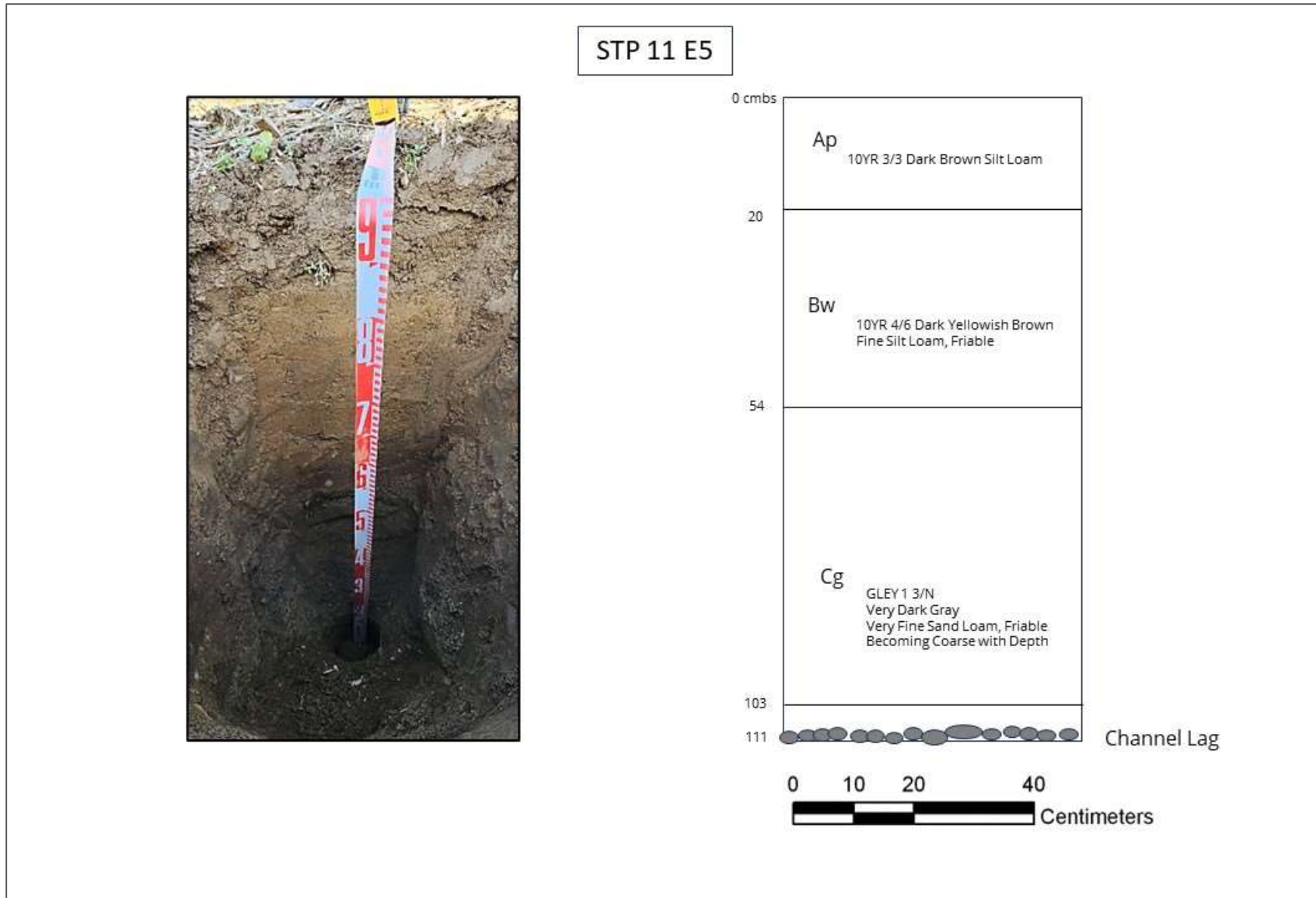


Figure 6: Representative Soil Profile from STP 11 E5



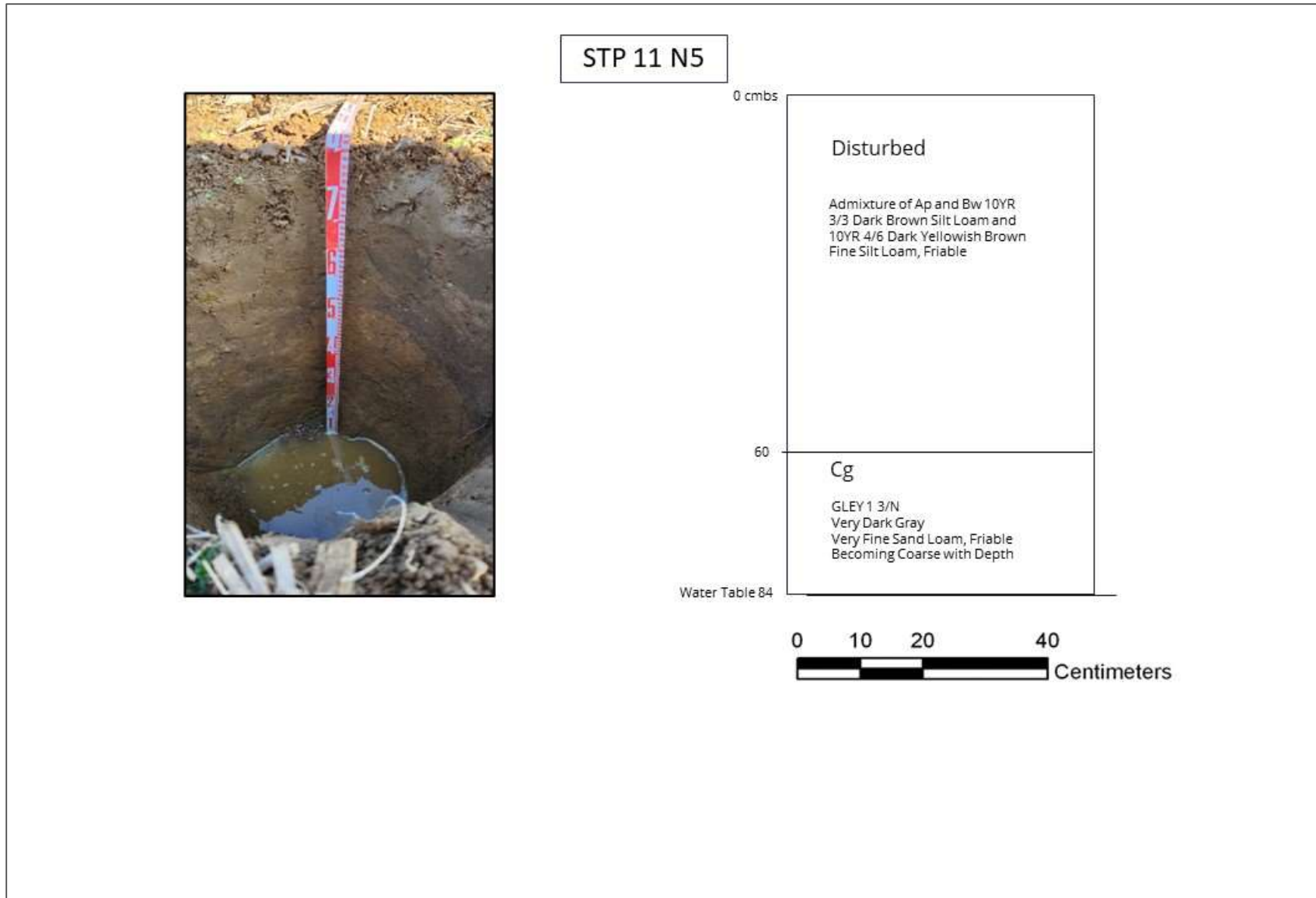


Figure 7: Representative Soil Profile from STP 11 N5

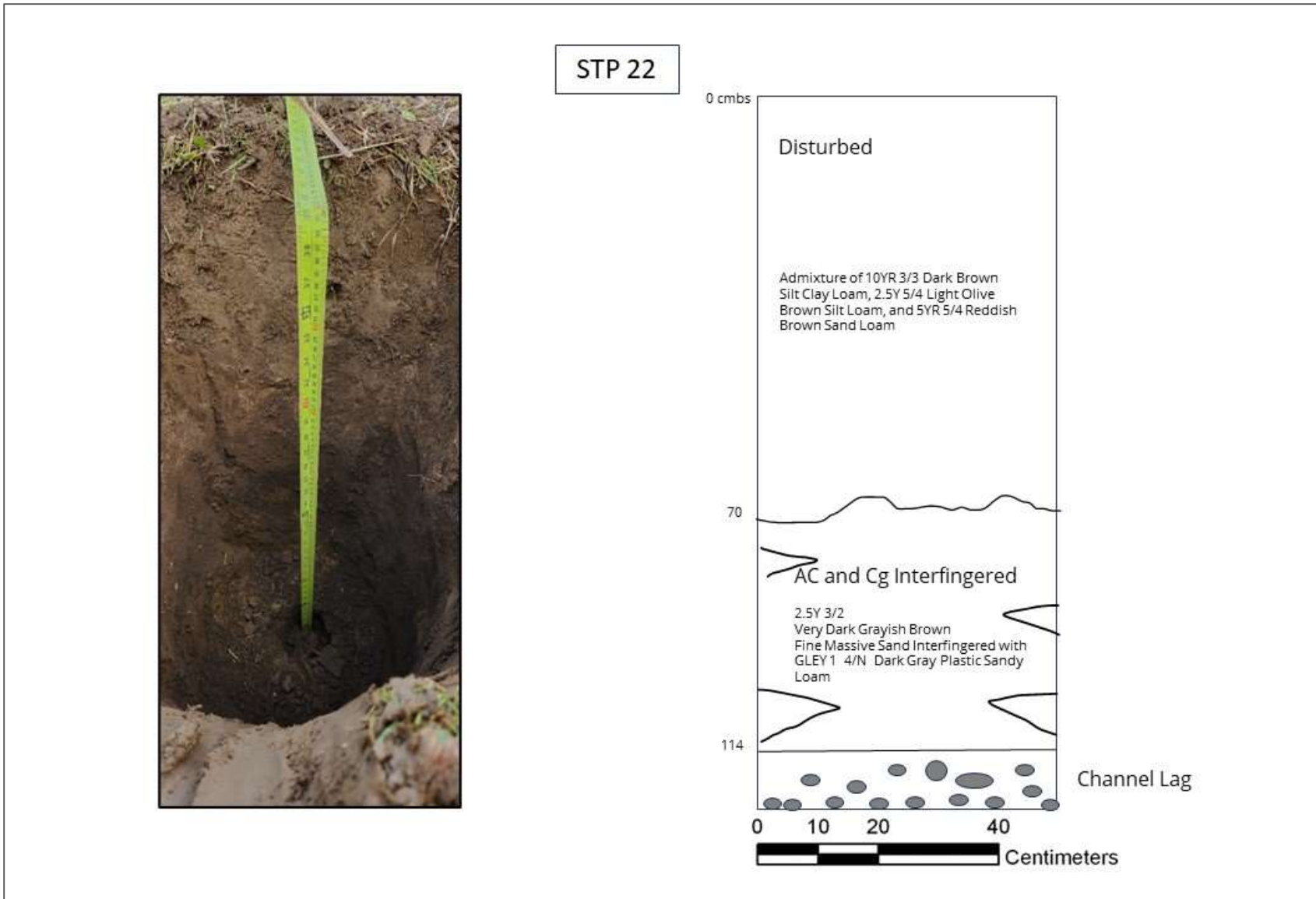
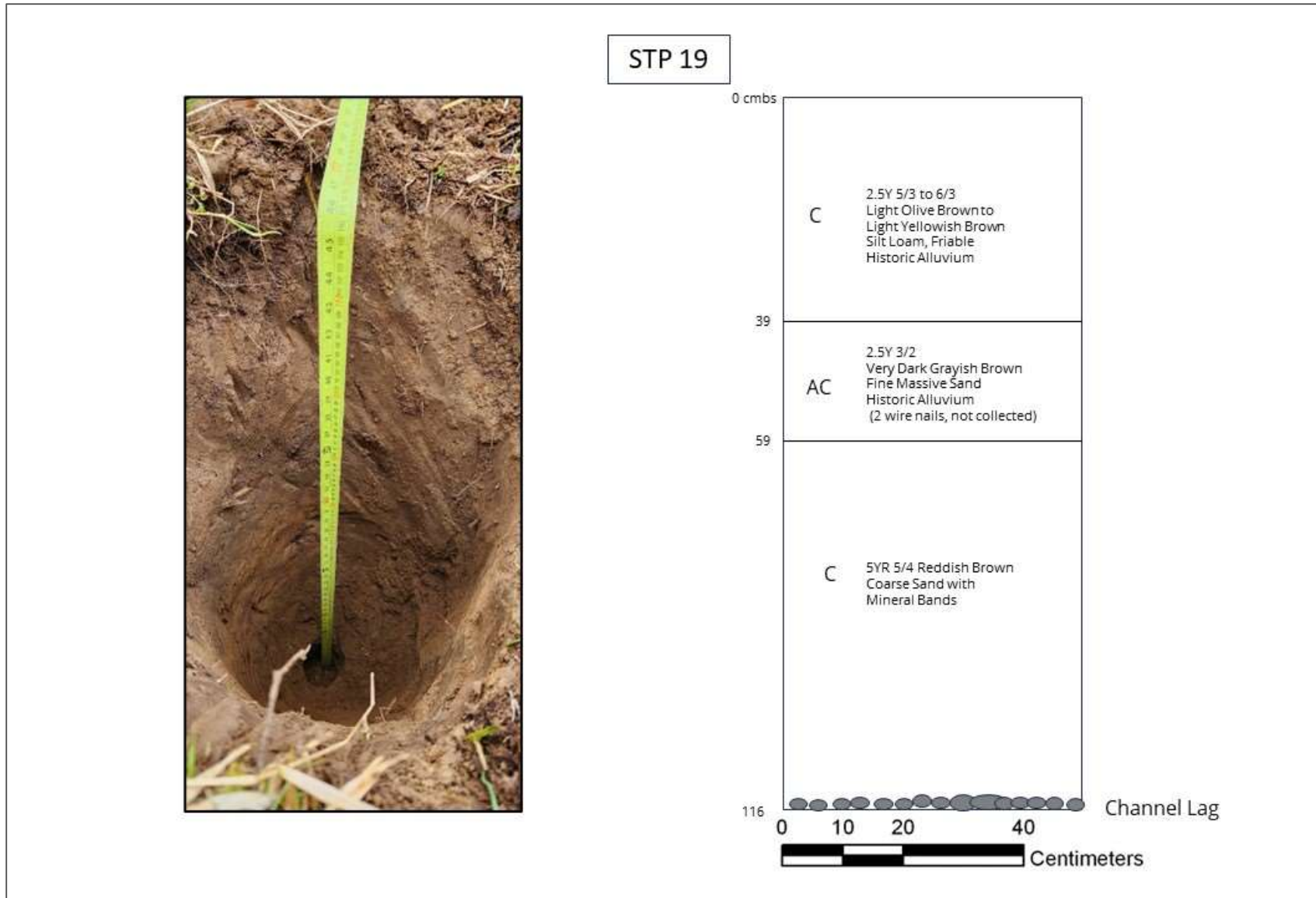


Figure 8: Representative Soil Profile from STP 22



**Figure 9: Representative Soil Profile from STP 19**



## Appendix D Artifact Inventory

Site	Field Specimen	Excavation Unit	UTM 17N (NAD 1983)		Stratum	Top Depth (cm)	Bottom Depth (cm)	Artifact Type	Material Type	Quantity
			Easting	Northing						
33WE0085	1	STP 8	424344	4517389	Ap	0	28	Flake Fragment	Black Chert	1
33WE0085	2	STP 8 E5	424349	4517389	Ap	0	38	Tertiary Flake	Light Gray Chert	1
33WE0085	3	STP 8E5N5	4243438	4517395	Ap	0	39	Flake Fragment	Gray Chert	1
33WE0085	4	STP 11	424320	4517362	Ap/Bw	0	27	Core Fragment/Scraper	Gray Chert	1



February 21, 2024

**BY EMAIL**

Diana Welling, Department Head  
Resource Protection and Review  
Ohio Historic Preservation Office  
800 East 17th Avenue  
Columbus, Ohio 43211-2474

**RE: The East Ohio Gas Company, Pipeline Infrastructure Replacement Program  
Cultural Resources Coordination  
PIR 2788 – Apple Creek, Wooster Township, Wayne County**

Dear Ms. Welling:

The East Ohio Gas Company, d/b/a Dominion Energy Ohio (DEO), requests review of the following information regarding the Pipeline Infrastructure Replacement (PIR) project, PIR 2788 – Apple Creek, located in Wooster Township, Wayne County.

DEO is proposing to replace approximately 3,900 feet of twelve (12)-inch natural gas steel pipeline with 3,900 feet of twenty (20)-inch steel pipeline under the PIR program. The purpose of the program is to replace existing pipe to ensure the safety and reliability of pipeline operations. The PIR 2788 project is located in Wooster Township, Wayne County road right-of-way (ROW) of N. Hillcrest Drive, an existing sixty (60)-ft wide utility easement which originates at N. Hillcrest Drive and extends northeast to S. Geyers Chapel Road, and a newly acquired sixty (60)-foot wide easement which originates as a private drive on the east side of N. Hillcrest Drive and extends east to Apple Creek.

One (1) copy of the following documentation is provided for review:

- Project Mapping (Attachment 1)
- Ohio Historic Inventory Forms (Attachment 2)
- Section 106 Project Summary Form (Attachment 3)
- Photograph log (Attachment 4)
- Phase I Archaeological Survey Report (Attachment 5)

DEO is requesting a review and seeking concurrence that this project will result in no adverse effects on cultural or historic resources. Please forward your response to the attention of:

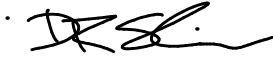
Greg Eastridge  
Environmental Specialist III  
320 Springside Drive, Suite 320  
Akron, Ohio 44333  
Gregory.K.Eastridge@dominionenergy.com



Cultural Resources Coordination  
PIR 2788 – Apple Creek  
Page 2 of 2

If you have any questions or need additional information, please contact Greg Eastridge at (330) 664-2576.

Sincerely,

A handwritten signature in black ink, appearing to read "DRS", with a horizontal line extending to the right.

Darrell R. Shier  
Authorized Representative  
Manager Environmental Services

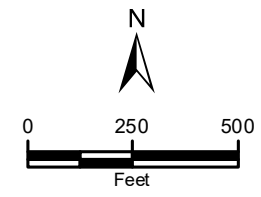
Attachments

cc: Gregory Eastridge

**Attachment 1**  
**Maps**



 Project Study Area




Base Layer: ESRI Street Map 2019

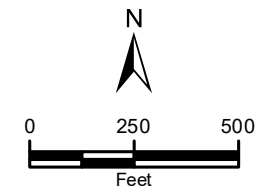
**Figure 1**  
**Site Location**  
PIR 2788 - Apple Creek  
Dominion Energy Ohio  
Wayne County, Ohio  
Date: 11/29/2023







 Project Study Area



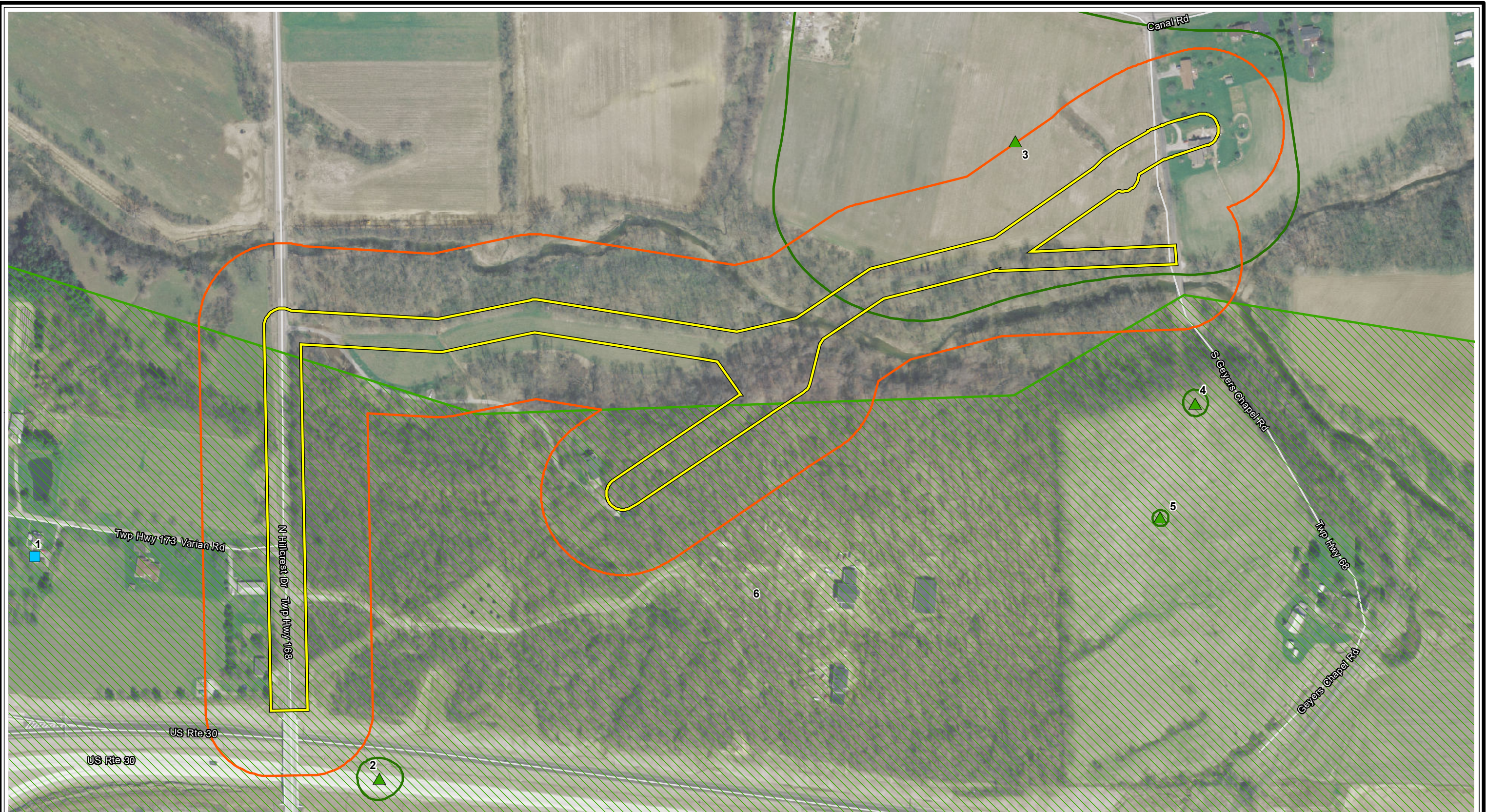
Base Layer: US TopoMaps, 1998

**Figure 2**  
**USGS Topographic - Wooster Quadrangle**

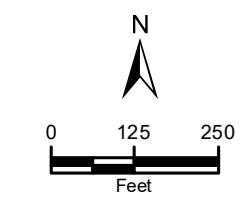
PIR 2788 - Apple Creek  
Dominion Energy Ohio  
Wayne County, Ohio  
Date: 11/29/2023







- Project Study Area/ APE
- 200-Foot Study Area Buffer
- Historic Structures
- ▲ Archaeological Sites
- OAI Site Boundaries
- Phase 1 Archaeological Survey



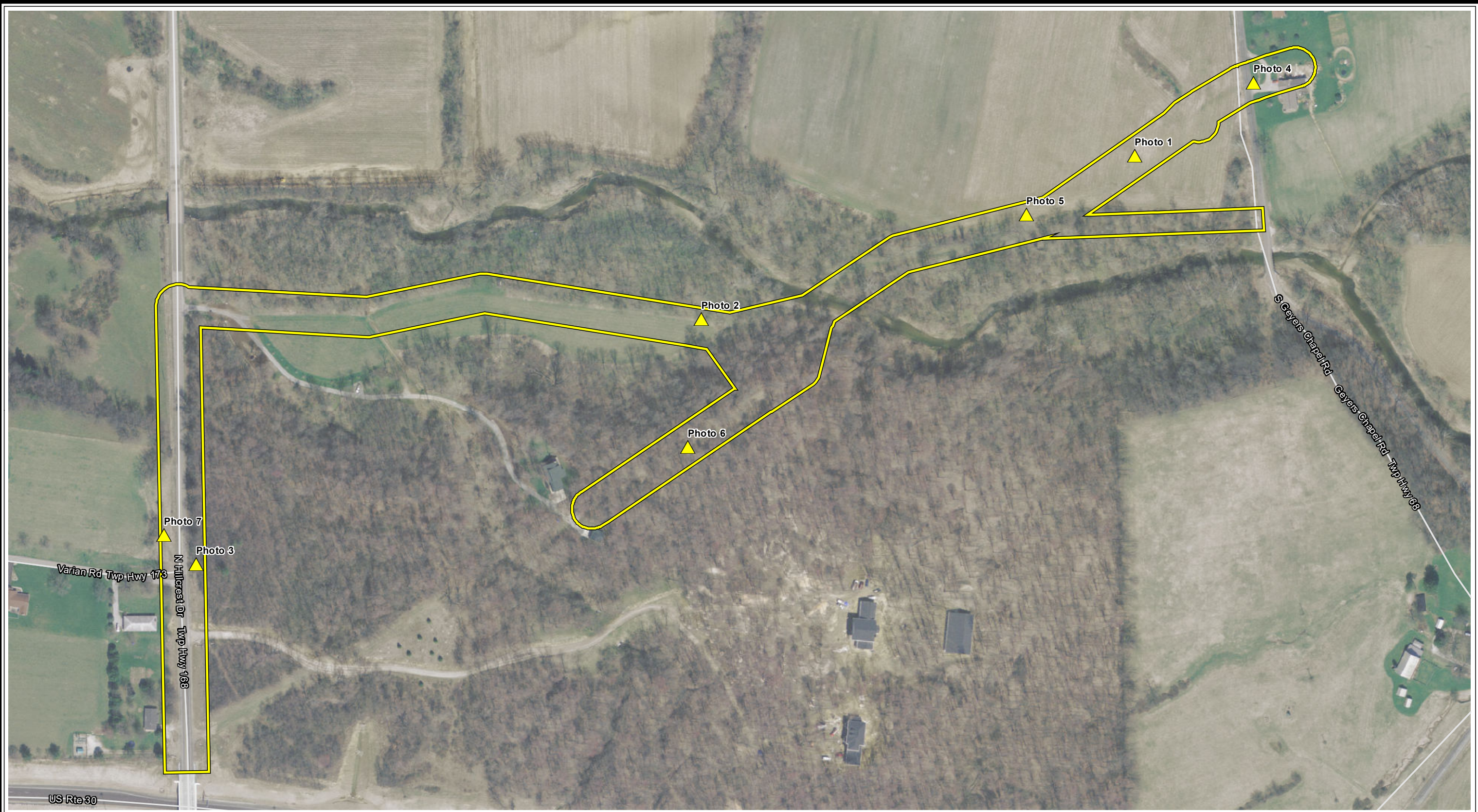
Base Layer: OSIP Aerial, 2016

**Figure 3**  
**Cultural Resources**

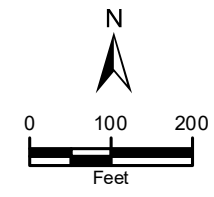
PIR 2788 - Apple Creek  
Dominion Energy Ohio  
Wayne County, Ohio  
Date: 12/12/2023







- Project Study Area
- ▲ Photo Location



Base Layer: OSIP Aerial, 2016

**Figure 4**  
**Photo Location Map**

PIR 2788 - Apple Creek  
Dominion Energy Ohio  
Wayne County, Ohio  
Date: 2/20/2024





**Attachment 2**  
**Ohio Historic Inventory Forms**



# OHIO ARCHAEOLOGICAL INVENTORY

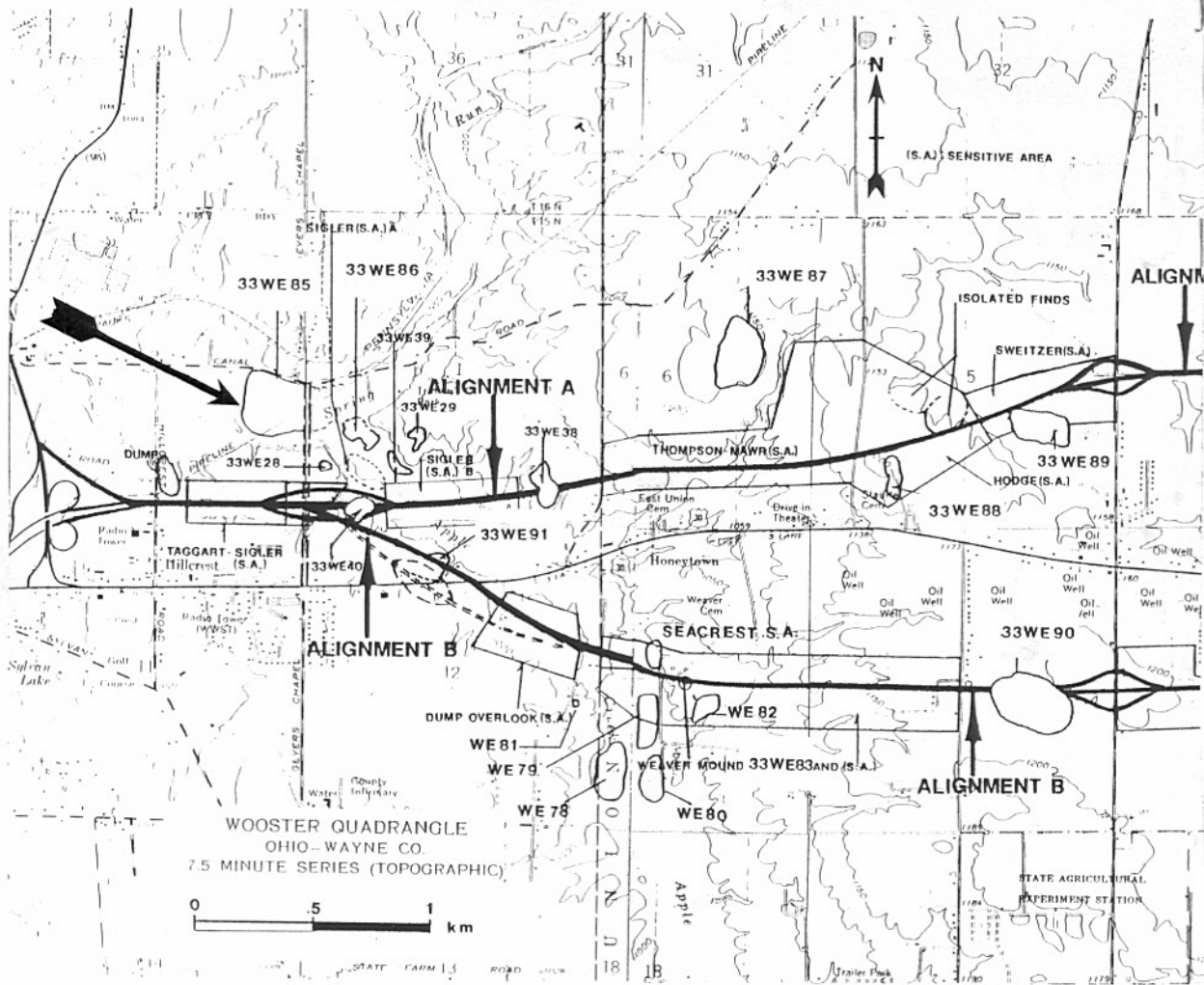
1. Site Number 33-WE-85		4. Site Name Taggart Farm Site		1. Site No. 33-WE-85																										
2. County Wayne		5. Other Names For Site L-1A			2. County Wayne																									
3. Township Wooster																														
6. City or Town Wooster		14. Land Form T-2, T-3		23. Ownership: Public <input type="checkbox"/> Private <input checked="" type="checkbox"/>																										
7. Map Reference U.S.G.S. 7.5 ' Series Wooster Quadrangle (1961)		15. Elevation 910-930			24. Form Prepared by  J. DeWert																									
8. Township & Range Number T15N R13W		16. Soil Type Lobdell - Fitchville - Chili		25. Organization OHS Archaeology																										
9. Section Number 2		17. Floral Cover unknown			26. Location of Negatives																									
10. Latitude " " "		18. Condition of Site Plow disturbed		27. Date of Survey 1/79																										
11. Longitude " " "		19. Present Use agricultural			28. Survey Conditions Poor																									
12. U.T.M. Reference		20. Type of Site unknown-village?		29. Cultural Classification or Time Period Unknown																										
<table border="1"> <tr> <td>1</td><td>7</td><td>4</td><td>2</td><td>4</td><td>2</td><td>4</td><td>0</td><td>4</td><td>5</td><td>1</td><td>6</td><td>2</td><td>7</td><td>0</td> </tr> <tr> <td colspan="4">Zone</td> <td colspan="4">Easting</td> <td colspan="4">Northing</td> </tr> </table>		1	7		4	2	4	2	4	0	4	5	1	6	2	7	0	Zone				Easting				Northing				21. Drainage System Apple Creek, Killbuck Wal- honding, Muskingum Ohio
1	7	4	2	4	2	4	0	4	5	1	6	2	7	0																
Zone				Easting				Northing																						
13. Verbal Site Location East on Route 30 from Wooster to Geyers Chapel Road. Left (North) on Geyers Chapel to Apple Creek Bridge. Site is located on north bank - floodplain west of Geyer Chapel, south of Canal Road and east of small intermittent.		22. Dimensions of Site unknown																												
30. Artifacts Collected None by this survey. D. W. Taggart collected charcoal, FCR, chert debitage and limited tools from testing he conducted in 1960.																														
31. References Roger Rowe of the Wayne County Historical Society has files on the Taggart excavations. DeWert, John; and Jeffrey Gardner 1982 Preliminary Archaeological Survey of the Proposed Route 30 East of Wooster in Wayne County, Ohio.																														
32. Remarks Site is not well defined to date. The survey crew <u>did not</u> field check the location.																														
33. Use opposite side to copy portion of topographic map with site located, attachment of contact print, sketch of site plan, or continuation of items 1-32.																														

1. Site No.  
33-WE-85

2. County  
Wayne

4. Site Name  
Taggart Farm Site

5. Other Names for Site  
L-1A



Continuation Sheet: Specify Section & Item (use additional Continuation Sheets if necessary)

- B1. change Easting to 424210  
Northing to 4517220 -
  
- D2. Unassigned Prehistoric
  
- E1. Open
  
- E2. Unknown
  
  
  
  
  
  
  
  
  
  
- E10. 279
- E11. Glaciated Plateau
- E12. Wisconsin Ground Moraine
- E13. Stream Valley
- E14. Unknown terrace
- E16. SW
- E17. Unrecorded
- E18. Major Drainage: Walkonding River  
Minor Drainage: Killbuck Creek
  
- E19. Ephemeral Stream
- E20. 162 NADB 15773

ANH  
6/26/02



**Attachment 3**  
**Section 106 Project Summary Form**



**OHIO HISTORIC PRESERVATION OFFICE:  
RESOURCE PROTECTION AND REVIEW**

**Section 106 Review - Project Summary Form**

**For projects requiring a license from the Federal Communications Commission, please use FCC Forms 620 or 621. DO NOT USE THIS FORM.**

**SECTION 1: GENERAL PROJECT INFORMATION**

All contact information provided must include the name, address and phone number of the person listed. Email addresses should also be included, if available. Please refer to the Instructions or contact an OHPO reviewer (mailto:Section106@ohiohistory.org) if you need help completing this Form. Unless otherwise requested, we will contact the person submitting this Form with questions or comments about this project.

Date: February 21, 2024

Name/Affiliation of person submitting form: Zachary Goodson, Dominion Energy Ohio

Mailing Address: 320 Springside Drive, Suite 320, OH 44333

Phone/Fax/Email: (330) 664-2576, Gregory.k.easteridge@dominionenergy.com  
(Contact Person: Greg Eastridge, on behalf of Zachary Goodson)

**A. Project Info:**

1. This Form provides information about:

New Project Submittal:

YES  NO

Additional information relating to previously submitted project:

YES  NO

OHPO/RPR Serial Number from previous submission:

N/A

2. Project Name (if applicable):

PIR 2788 – Apple Creek

3. Internal tracking or reference number used by Federal Agency, consultant, and/or applicant to identify this project (if applicable):

U.S. Army Corps of Engineers No. (LRH-2021-00340-WAL)

B. Project Address or vicinity:

40.802787°, -81.900774°

C. City/Township:

Wooster Township

D. County:

Wayne County

E. Federal Agency and Agency Contact. *If you do not know the federal agency involved in your project, please contact the party asking you to apply for Section 106 Review, not OHPO, for this information. HUD Entitlement Communities acting under delegated environmental review authority should list their own contact information.*

U.S. Army Corps of Engineers, Michelle Doolin,  
[michelle.m.doolin@usace.army.mil](mailto:michelle.m.doolin@usace.army.mil)

While this submittal is being made to satisfy the requirements for project review by the Ohio Power Siting Board, the U.S. Army Corps of Engineers is aware of this coordination request and has asked for a copy of the response.

F. Type of Federal Assistance. *List all known federal sources of federal funding, approvals, and permits to avoid repeated reviews.*

Nationwide Permit 12 – Oil or Natural Gas Pipeline Activities

G. State Agency and Contact Person (if applicable):

Public Utilities Commission of Ohio (PUCO)

H. Type of State Assistance:

Ohio Power Siting Board (OPSB)

I. Is this project being submitted at the direction of a state agency **solely** under Ohio Revised Code 149.53 or at the direction of a State Agency? *Answering yes to this question means that you are sure that no federal funding, permits or approvals will be used for any part of your project, and that you are seeking comments only under ORC 149.53.*

YES  NO

J. Public Involvement- Describe how the public has been/will be informed about this project and its potential to affect historic properties. Please summarize how they will have an opportunity to provide comments about any effects to historic properties. (This step is required for all projects under 36 CFR § 800.2):

This Project is being reviewed by the OPSB. As part of the OPSB permitting process, all application documents are public. A copy of the OPSB application will be posted. The application is also available to the public via Dominion



Energy Ohio's (DEO's) webpage. Anyone may submit questions or comments about the project to the PUCO.

- K. Please list other consulting parties that you have contacted/will contact about this project, such as Indian Tribes, Certified Local Governments, local officials, property owners, or preservation groups. (See 36 CFR § 800.2 for more information about involving other consulting parties). Please summarize how they will have an opportunity to provide comments:

N/A

## **SECTION 2: PROJECT DESCRIPTION AND AREA OF POTENTIAL EFFECTS (APE)**

Provide a description of your project, its site, and geographical information. You will also describe your project's Area of Potential Effects (APE). Please refer to the Instructions or contact an OHPO reviewer if you need help with developing the APE or completing this form.

*For challenging projects, provide as much information as possible in all sections, and then check the box in Section 5.A. to ask OHPO to offer preliminary comments or make recommendations about how to proceed with your project consultation. This is recommended if your project involves effects to significant historic properties or if there may be challenging procedural issues related to your project. Please note that providing information to complete all Sections will still be required and that asking OHPO for preliminary comments may tend to delay completion of the review process for some projects.*

- A. Does this project involve any Ground-Disturbing activity:  YES  NO  
(If **Yes**, you must complete all of Section 2.A. If **No**, proceed directly to Section 2. B.)

1. General description of width, length and depth of proposed ground disturbing activity:

Approximately 3,900 linear feet of natural gas pipeline will be installed to replace or relocate existing pipeline. The pipeline activities will occur within a ten (10)-foot construction corridor within the road right-of-way (ROW) along the western side of N. Hillcrest Drive as well as a sixty (60)-foot wide easement through a newly acquired utility easement running from a private drive along N. Hillcrest drive east to Apple Creek and the existing utility easement area running northeast of Apple Creek to South Geyers Chapel Road. To replace the pipeline, the existing steel pipeline will be removed or abandoned in place and a new pipe will be replaced in a three (3)-foot wide, five and a half (5.5)-foot deep trench. Additionally, a drip tank with 2-inch siphon riser and protective bollards, and permanent gravel access road will be installed within a section of the newly acquired easement off of N. Hillcrest Drive. Aside from the excavation of the trench, soils may be disturbed from ancillary construction activity within the full work area. Disturbance within the work area may total approximately 5.4 acres.

2. Narrative description of previous land use and past ground disturbances, if known:

The Project is located in an agricultural, rural residential setting. The Project area was previously cleared and disturbed for the installation of the current pipeline, residential buildings, and public and private roadways. Based on aerial imagery, the northeastern portion of the Project area has also been under active agricultural practices with very little change since at least 1994.

3. Narrative description of current land use and conditions:

The Project area is dominated by undeveloped, agricultural, and rural residential areas. The study area primarily has land cover of mature woods, active agricultural fields, fallow/old fields, maintained lawns, and emergent, scrub-shrub, and forested wetland areas. One (1) large wetland borders sections of Apple Creek which bisects the northeastern portion of the Project Area.

4. Does the landowner know of any archaeological resources found on the property?  
 YES  NO If yes, please describe:

One (1) Ohio Archaeological Inventory Site, the Taggart Farm Site (WE0085), overlaps the northeastern Project Area. The exact location of the site is unknown, and the site boundary as shown on the attached mapping is approximated by the Ohio Historic Preservation Office.

- B. Submit the exact project site location on a USGS 7.5-minute topographic quadrangle map for all projects. Map sections, photocopies of map sections, and online versions of USGS maps are acceptable as long as the location is clearly marked. Show the project's Area of Potential Effects (APE). It should be clearly distinguished from other features shown on the map:

1. USGS Quad Map Name:

Wooster Quadrangle

2. Township/City/Village Name:

Wooster Township

- C. Provide a street-level map indicating the location of the project site; road names must be identified and legible. Your map must show the exact location of the boundaries for the project site. Show the project's Area of Potential Effects (APE). It should be clearly distinguished from other features shown on the map:
- D. Provide a verbal description of the APE, including a discussion of how the APE will include areas with the potential for direct and indirect effects from the project. Explain the steps taken to identify the project's APE, and your justification for the specific boundaries chosen:

The APE includes a 3-meter (10-foot) wide corridor along North Hillcrest Drive and an 18.3-m (60-ft) wide limit of disturbance (LOD) in the utility easements with a combined area measuring approximately 4.26-acres. Two potential access roads, with a combined area of 0.98 acres, extending west from South Geyers Chapel Road to the pipeline replacement LOD are also being evaluated for potential use during installation of the new pipe. If incorporated into the Project design, ground disturbances derived from the proposed access road will be limited to surficial disturbances from the movement of vehicles and equipment and the installation, use, and removal of timber matting to cross any wetlands within the proposed access road corridors. As the pipeline and drip tank will be buried, visual impacts from the project on adjacent properties is limited to tree clearing necessary to maintain the existing easement, a 2 inch drip riser, and 4 bollards surrounding the drip syphon. Therefore, an APE for visual impacts is not included.

- E. Provide a detailed description of the project. This is a critical part of your submission. Your description should be prepared for a cold reader who may not be an expert in this type of project. The information provided must help support your analysis of effects to historic

properties, not other types of project impacts. Do not simply include copies of environmental documents or other types of specialized project reports. If there are multiple project alternatives, you should include information about all alternatives that are still under active consideration:

DEO is proposing to install approximately 3,900 feet of replacement or relocated natural gas pipeline. This work is being conducted under DEO's Pipeline Infrastructure Replacement (PIR) program. The purpose of this program is to replace existing pipe to ensure the safety and reliability of pipeline operations.

The pipeline activities will occur within a ten (10)-foot construction corridor within the road right-of-way (ROW) along N. Hillcrest Drive as well as a sixty (60)-foot wide easement through the newly acquired utility easement, and existing utility easement area northeast of Apple Creek. A trench will be excavated to remove the old pipeline or to install the new pipeline parallel to the existing line, which will be abandoned, and to relocate a section of pipeline. The trench will be excavated to allow sufficient cover over the new pipeline after installation and backfilling. The construction activities will require soil disturbance within road ROW and the easement to accommodate areas for trench excavation, side-cast spoil storage, and temporary storage of the new and removed pipe. All work shall be performed within authorized limits of disturbance. The existing pipeline within the existing easement southwest of Apple Creek will be abandoned and minor excavation is expected to perform abandonment work. The replacement pipeline will be installed in a portion of the existing easement, in the newly acquired easement, and along road ROW. Additionally, a drip tank, consisting of a section of large diameter pipeline which has been capped and sealed, will be buried next to the newly installed pipeline. A 2-inch siphon riser will be above ground to evacuate liquids from the "tank". The riser will be protected by 4 bollards. A permanent, ground-level, gravel, access road/drive will be installed. The drip tank and access drive will be within a section of the newly acquired easement off of N. Hillcrest Drive.

### **SECTION 3: IDENTIFICATION OF HISTORIC PROPERTIES**

Describe whether there are historic properties located within your project APE. To make that determination, use information generated from your own Background Research and Field Survey. Then choose one of the following options to report your findings. Please refer to the Instructions and/or contact an OHPO reviewer if you are unsure about how to identify historic properties for your project.

*If you read the Instructions and you're still confused as to which reporting option best fits your project, or you are not sure if your project needs a survey, you may choose to skip this section, but provide as much supporting documentation as possible in all other Sections, then check the box in Section 5.A. to request preliminary comments from OHPO. After reviewing the information provided, OHPO will then offer comments as to which reporting option is best suited to document historic properties for your project. Please note that providing information to complete this Section will still be required and that asking OHPO for preliminary comments may tend to delay completion of the review process for some projects.*

#### **Recording the Results of Background Research and Field Survey:**

- A. **Summary of discussions and/or consultation with OHPO** about this project that demonstrates how the Agency Official and OHPO have agreed that no Field Survey was necessary for this project (typically due to extreme ground disturbance or other special circumstances). Please **attach copies** of emails/correspondence that document this agreement. You must explain how the project's potential to affect both archaeological and historic resources were considered.



- B. **A table that includes the minimum information** listed in the OHPO Section 106 Documentation Table (which is generally equivalent to the information found on an inventory form). This information must be printed and mailed with the Project Summary Form. To provide sufficient information to complete this Section, you must also include summary observations from your field survey, background research and eligibility determinations for each property that was evaluated in the project APE.
- C. **OHI (Ohio Historic Inventory) or OAI (Ohio Archaeological Inventory) forms-** New or updated inventory forms may be prepared using the OHI pdf form with data population capabilities, the Internet IForm, or typed on archival quality inventory forms. To provide sufficient information to complete this Section, you must include summary observations from your field survey and background research. You must also include eligibility determinations for each property that was evaluated in the project APE
- D. **A historic or archaeological survey report** prepared by a qualified consultant that meets professional standards. The survey report should meet the Secretary of the Interior's Standards and Guidelines for Identification and OHPO Archaeological Guidelines. You may also include new inventory forms with your survey, or update previous inventory forms. To complete this section, your survey report must include summary observations from your field survey, background research and eligibility determinations for each property that was evaluated within the APE.

Phase I Archaeological Report submitted concurrently with Section 106 Project Review Form.

- E. **Project Findings.** Based on the conclusions you reached in completing Section 3, please choose one finding for your project. There are (mark one):

Historic Properties Present in the APE:

No Historic Properties Present in the APE:

**See Attached Avoidance Plan in Phase I Archaeological Report (Figure8)**

**SECTION 4: SUPPORTING DOCUMENTATION**

This information must be provided for all projects.

- A. Photographs must be keyed to a street-level map, and should be included as attachments to this application. Please label all forms, tables and CDs with the date of your submission and project name, as identified in Section 1. You must present enough documentation to clearly show existing conditions at your project site and convey details about the buildings, structures or sites that are described in your submission. Faxed or photocopied photographs are not acceptable. See Instructions for more info about photo submissions or 36 CFR § 800.11 for federal documentation standards.
  - 1. Provide photos of the entire project site and take photos to/from historic properties from/towards your project site to support your determination of effect in Section 5.
  - 2. Provide current photos of all buildings/structures/sites described.
- B. Project plan, specifications, site drawings and any other media presentation that conveys detailed information about your project and its potential to affect historic properties.
- C. Copies or summaries of any comments provided by consulting parties or the public.

**SECTION 5: DETERMINATION OF EFFECT**

A. **Request Preliminary Comments.** For challenging projects, provide as much information as possible in previous sections and ask OHPO to offer preliminary comments or make recommendations about how to proceed with your project consultation. This is recommended if your project involves effects to significant historic properties, if the public has concerns about your project's potential to affect historic properties, or if there may be challenging procedural issues related to your project. Please be aware that providing information in all Sections will still be required and that asking OHPO for preliminary comments may tend to delay completion of the review process for some projects.

1. We request preliminary comments from OHPO about this project:

YES  NO

2. Please specify as clearly as possible the particular issues that you would like OHPO to examine for your project (for example- help with developing an APE, addressing the concerns of consulting parties, survey methodology, etc.):

DEO requests concurrence that the project will have no affects on historic properties.

B. **Determination of Effect.** If you believe that you have gathered enough information to conclude the Section 106 process, you may be ready to make a determination of effect and ask OHPO for concurrence, while considering public comments. Please select and mark one of the following determinations, then explain the basis for your decision on an attached sheet of paper:

**No historic properties will be affected** based on 36 CFR § 800.4(d) (1).

Please explain how you made this determination:

The site boundary as depicted in the Ohio Archaeological Inventory (OAI) records is approximated and extends across nearly 32 acres of residential and agricultural lands, of which, approximately 2.27 acres intersect the disturbance limits of the project area. A Phase I archaeological survey of the approximately 2.27 acres of site 33WE0085 that intersect the Project area (Survey Area) was conducted in late January and Early February 2024. The purpose of the survey was to relocate any portions of site 33WE0085 that may remain intact within the Survey Area and to make recommendations as to the need for further work or avoidance of the site.

A total of 45 STPs were excavated within the Survey Area. Shovel testing recovered four prehistoric artifacts and identified one potential cultural feature within the Survey Area in an area bisected by the existing pipeline. Due to disturbances from the existing pipeline, the limited archaeological context inherent in the channel lag deposits underlying the Study Area resulting from the lateral migration of Apple Creek, the low density of artifacts, and the extent of negative shovel testing, the only portion of site 33WE0085 within the Survey Area that retains the potential to contain significant information is the potential feature.

DEO has elected to avoid impacts to the potential feature to the extent practicable. No excavation will occur within 10 meters (32.8 feet) to the east and west of STP 11 and the identified site. However, timber matting may be placed on the soil surface to allow for equipment access to the site. As the

feature is placed as the base of the plow zone and timber matting will adequately distribute the weight of machinery over the site, impacts to the underlying site is anticipated to be minimal. Temporary construction fencing will be installed around STP 11 in areas that are not timber matted. Given the limited amount of testing conducted within the mapped 32-acres boundary of site 33WE0085, the site cannot presently be evaluated for listing in the NRHP. However, with the avoidance plan implemented, the portions of site 33WE0085 remaining within the Project area do not contribute to the site's potential eligibility for listing in the NRHP.

**No Adverse Effect** [36 CFR § 800.5(b)] on historic properties. This finding cannot be used if there are no historic properties present in your project APE. Please explain why the Criteria of Adverse Effect, [36 CFR Part 800.5(a) (1)], were found not to be applicable for your project:

**Adverse Effect** [36 CFR § 800.5(d) (2)] on historic properties. Please explain why the criteria of adverse effect, [36 CFR Part 800.5(a) (1)], were found to be applicable to your project. You may also include an explanation of how these adverse effects might be avoided, reduced or mitigated:


*Please print and mail completed form and supporting documentation to:*

*State Historic Preservation Office  
Resource Protection and Review Department  
800 E. 17<sup>th</sup> Avenue  
Columbus, OH 43211-2474*



**Attachment 4**  
**Photographs**


## > Photographic Log


<b>Photo # 1</b>	
Date: 05/13/2020	
Feature: Land Cover- Agricultural Areas	
Description: The northern portion of the Project area crosses active agricultural fields.	

<b>Photo # 2</b>	
Date: 04/30/2021	
Feature: Land Cover - Fallow Field/Lawn	
Description: The southwestern Project area crosses a newly fallow field/maintained lawn along the edge of a forested wetland (Wetland A).	




## > Photographic Log


<b>Photo # 3</b>	
Date: 11/18/2020	
Feature: Land Cover – Road right-of-way	
Description: The western portion of the Project area runs along the road right-of-way of N. Hillcrest Drive.	

<b>Photo # 4</b>	
Date: 05/13/2020	
Feature: Land Cover - Residential Area	
Description: The northern extent of the Project area abuts a residential property along Geyers Chapel Road.	




## > Photographic Log

<b>Photo # 5</b>	
Date: 05/13/2020	
Feature: Archaeological Site	
Description: One previously identified archaeological site, the Taggart Farm Site, overlaps the northeastern boundary of the Project area. This area is currently under active row crop.	

<b>Photo # 6</b>	
Date: 05/13/2020	
Feature: Phase I Survey Area	
Description: A previous Phase II Archaeological Survey overlaps southern portions of the Project area. This area is mainly comprised of forested areas with a maintained open pipeline easement, fallow field, and road right-of way.	



## > Photographic Log

<b>Photo #</b>	<b>7</b>
Date: 11/18/2020	
Feature: Phase I Study Area	
Description: A previous Phase II Archaeological study was conducted within southern portions of the Project area. Most of the area is now maintained lawn, pipeline easement, and road right-of-way.	
	

**Attachment 5**  
**Phase 1 Archaeological Survey Report**



> **Phase I Archaeological Survey**  
**PIR 2788 – Apple Creek**  
**Wooster Township, Wayne County, Ohio**

February 2024  
ECT No. 200336-0002

The East Ohio Gas Company, d/b/a Dominion Energy Ohio  
320 Springside Drive, Suite 320  
Akron, Ohio 44333



161 East Aurora Road  
Northfield, OH 44067  
[www.ectinc.com](http://www.ectinc.com)

## Document Review

The dual signatory process is an integral part of Environmental Consulting & Technology, Inc.'s (ECT's) Document Review Policy. All ECT documents undergo technical/peer review prior to dispatching these documents to any outside entity.

This document has been authored and reviewed by the following employees:

\_\_\_\_\_  
Matthew Lockett  
Author

\_\_\_\_\_  
*Matthew M. Lockett*  
Signature

\_\_\_\_\_  
February 13, 2024  
Date

\_\_\_\_\_  
James Marine  
Peer Review

\_\_\_\_\_  
*James J Marine*  
Signature

\_\_\_\_\_  
February 13, 2024  
Date

# Phase I Archaeological Survey PIR 2788 – Apple Creek Wooster Township, Wayne County, Ohio

**Prepared For:**

The East Ohio Gas Company, d/b/a Dominion Energy Ohio  
320 Springside Drive, Suite 320  
Akron, Ohio 44333

**Lead Agency:**

United States Army Corps of Engineers  
Huntington Regulatory District  
502 Eighth Street  
Huntington, WV 25701

**Prepared By:**

Environmental Consulting & Technology, Inc  
161 East Aurora Road  
Northfield, OH 44067

**Authors:**

Matthew M. Lockett  
James T. Marine

James T. Marine MS/RPA  
Principal Investigator / Geomorphologist

FEBRUARY 2024



## Executive Summary

The East Ohio Gas Company, d/b/a Dominion Energy Ohio (DEO) is proposing to replace approximately 1,188.7 meters (m) (3,900 feet [ft]) of twelve (12)-inch natural gas steel pipeline under DEO's Pipeline Infrastructure Replacement (PIR) program. The purpose of the program is to replace existing pipe to ensure the safety and reliability of pipeline operations. The PIR 2788 – Apple Creek project (Project) is located in Wooster Township, Wayne County. The Project is being permitted under United States Army Corps of Engineers (USACE) Nationwide Permit 12 and is subject to review by the Ohio Power Siting Board.

Initial background research for the Project identified one (1) previously recorded archaeological site within the limits of disturbance (LOD) between Apple Creek and South Geyers Chapel Road. Site 33WE0085, the Taggart Farm Site, is a prehistoric site of unknown function that has not been evaluated for listing in the National Register of Historic Places (NRHP). Site records indicate the site was initially identified by the landowner in the 1960s but was not recorded until 1979. The site was recorded based on information provided by the landowner but was never field checked. The site boundary as depicted in the site records is approximated and extends across nearly 32 acres of residential and agricultural lands, of which approximately 2.27 acres intersect the Project.

As the exact location and extent of site 33WE0085 is not presently known, DEO requested Environmental Consulting & Technology, Inc (ECT) conduct a Phase I archaeological survey of the approximately 2.27 acres of site 33WE0085 that intersect the Project (Survey Area). The purpose of the survey is to relocate any portions of site 33WE0085 that may remain intact within the Survey Area and to make recommendations as to the need for further work or avoidance of the site.

The Phase I archaeological survey was conducted in January and February 2024. A total of 45 STPs were excavated within the Survey Area. Shovel testing recovered four (4) prehistoric artifacts and identified one (1) potential cultural feature within the Survey Area in an area bisected by the existing pipeline. Given the nebulous nature of the original site boundary, it is not clear if the artifacts recovered represent the original location of site 33WE0085 or if the occupation identified during this investigation is one (1) of many possible site locations situated within the approximately 32-acre area mapped as site 33WE0085.

Due to disturbances from the existing pipeline, the limited archaeological context inherent in the channel lag deposits underlying the Study Area resulting from the lateral migration of Apple Creek, the low density of artifacts, and the extent of negative shovel testing, it is ECT's conclusion that the only portion of site 33WE0085 within the Survey Area that retains the potential to contain significant information is the potential feature identified in STP 11. Therefore, ECT recommends the feature be avoided. If the potential feature cannot be avoided, ECT recommends the anomaly be revisited and fully exposed and excavated to determine if the charcoal concentration is cultural in origin and to collect any additional data (e.g., datable organic material or floral and faunal remains).

DEO has elected to avoid impacts to the potential feature. Temporary construction fencing will be installed around STP 11. The avoidance buffer will extend 10 m (32.8 ft) to the east and west of STP 11 between the existing pipeline trench and the southern boundary of the LOD. No excavation will occur within this avoidance buffer. However, DEO may place timber matting on the ground surface to allow for equipment to traverse the LOD. As the potential feature was identified at the base of the plowzone, approximately 27 centimeters (10.6 inches) below surface, the timber matting will adequately distribute the weight of machinery over the site and avoid impacts to the potential feature. Given the limited amount of testing conducted within the mapped 32-acres boundary of site 33WE0085, the site cannot presently be evaluated for listing in the NRHP. However, with the avoidance plan implemented, ECT recommends the portions of site 33WE0085 remaining within the Project LOD do not contribute to the site's potential eligibility for listing in the NRHP.

## Table of Contents

<b>Executive Summary .....</b>	<b>i</b>
<b>1.0 Introduction .....</b>	<b>1</b>
<b>2.0 Environmental Setting .....</b>	<b>3</b>
2.1 Physiography and Geology .....	3
2.2 Soils.....	3
2.3 Pleistocene and Holocene Paleoenvironment.....	3
<b>3.0 Cultural Context .....</b>	<b>6</b>
3.1 Prehistoric Context.....	6
3.1.1 Paleoindian Period (11,500 to 10,000 years BP) .....	6
3.1.2 Early Archaic Period (10,000 to 8,000 years BP) .....	8
3.1.3 Middle Archaic Period (8,000 to 5,500 years BP) .....	10
3.1.4 Late Archaic Period (3,500 to 1,000 years BP).....	10
3.1.5 Transitional Period (3,000 to 2,000 years BP) .....	11
3.1.6 Early Woodland Period (2,600 to 2,100 years BP) .....	12
3.1.7 Middle Woodland Period (2,100 to 1,500 years BP) .....	12
3.1.8 Late Woodland Period (1,500 to 800 years BP).....	13
3.1.9 Late Prehistoric Period (800 to 350 years BP).....	14
3.2 Historic Context.....	15
3.2.1 Frontier (ca. 1775–1795) .....	15
3.2.2 Settlement (1796–1819) .....	15
3.2.3 Immigration .....	16
3.2.4 The Industrial Period (ca. 1850–1930).....	17
3.2.5 Mid-Twentieth Century (1930–1960).....	18
3.2.6 Late-Twentieth and Early-Twenty-First Centuries (1960-present day) .....	19
<b>4.0 Methodology .....</b>	<b>20</b>
4.1 Background Research Methods.....	20
4.2 Field Methods .....	20
4.3 Artifact Analysis and Curation.....	21
<b>5.0 Results.....</b>	<b>22</b>
5.1 Results of Background Research .....	22
5.2 Results of Fieldwork .....	25



**6.0 Summary and Recommendations..... 30**  
**7.0 References Cited ..... 32**

**Appendices**

- Appendix A Background Figures
- Appendix B Photographs
- Appendix B Representative Soil Profiles
- Appendix D Artifact Inventory

**List of Tables**

Table 1: Previously Completed Cultural Resources Surveys within DSA .....22  
Table 2: Previously Recorded Archaeological Sites within the DSA.....23  
Table 3: Previously Recorded Above Ground Resources in the DSA.....24

## List of Acronyms and Abbreviations

BP	years before present
c.	circa
cm	centimeter
DEO	East Ohio Gas Company, d/b/a Dominion Energy Ohio
DSA	Desktop Survey Area
ECT	Environmental & Consulting Technology, Inc.
ft	foot
in	inch
km	kilometer
LOD	Limits of Disturbance
m	meter
mi	mile
NRCS	Natural Resources Conservation Service
NRHP	National Register of Historic Places
OAI	Ohio Archaeological Inventory
OHPO	Ohio Historic Preservation Office
PIR	Pipeline Infrastructure Replacement
Project	PIR 2788 – Apple Creek
STP	Shovel Test Pit
Survey Area	Approximately 2.27 acres of Project intersecting site 33WE0085
USACE	United States Army Corps of Engineers
USDA	United States Department of Agriculture
USGS	United States Geological Survey

## 1.0 Introduction

The East Ohio Gas Company, d/b/a Dominion Energy Ohio (DEO) is proposing to replace approximately 1,188.7 meters (m) (3,900 feet [ft]) of twelve (12)-inch natural gas steel pipeline under DEO's Pipeline Infrastructure Replacement (PIR) program. The purpose of the program is to replace existing pipe to ensure the safety and reliability of pipeline operations. The PIR 2788 – Apple Creek project (Project) is located in Wooster Township, Wayne County (*USGS Topographic Map, Appendix A, Figure 1*). The Project requires a United States Army Corps of Engineers (USACE) Nationwide Permit 12 for Oil or Natural Gas Pipeline Activities and is subject to review by the Ohio Power Siting Board.

DEO proposes to install the pipeline within the road-right-of way of North Hillcrest Drive, a newly acquired utility easement on private property, and the existing utility easement between a section of Apple Creek and South Geyers Chapel Road (*Project Location Map, Appendix A, Figure 2*). To replace the pipeline, the existing steel pipeline will be removed or abandoned in place and a new pipe will be replaced within a 0.91-m (3-ft) wide, 1.8-m (5.5-ft) deep trench. Construction activities will be limited to a 3-m (10-ft) wide corridor along North Hillcrest Drive and an 18.3-m (60-ft) wide limit of disturbance (LOD) in the utility easements with a combined area measuring approximately 4.26-acres. Two (2) potential access roads, with a combined area of 0.98 acres, extending west from South Geyers Chapel Road to the pipeline replacement LOD are also being evaluated for potential use during installation of the new pipe. If incorporated into the Project design, ground disturbances derived from the proposed access road will be limited to surficial disturbances from the movement of vehicles and equipment and the installation, use, and removal of timber matting to cross any wetlands within the proposed access road corridors.

Initial background research for the Project identified one (1) previously recorded archaeological site within the LOD between Apple Creek and South Geyers Chapel Road. Site 33WE0085, the Taggart Farm Site, is a prehistoric site of unknown function that has not been evaluated for listing in the National Register of Historic Places (NRHP). Site records indicate the site was initially identified by the landowner in the 1960s but was not recorded until 1979. The site was recorded based on information provided by the landowner but was never field checked. The site boundary as depicted in the Ohio Archaeological Inventory (OAI) records is approximated and extends across nearly 32 acres of

residential and agricultural lands, of which, approximately 2.27 acres intersect the LOD (*Survey Area Map, Appendix A, Figure 3*).

General Condition 20(c) of Nationwide Permit 12 requires the applicant to submit a pre-construction notice to the district engineer should the permitted activity have the potential to cause effects to resources listed in, determined eligible, or potentially eligible for listing in the NRHP. Since the exact location and extent of site 33WE0085 is not presently known, DEO requested Environmental Consulting & Technology, Inc (ECT) conduct a Phase I archaeological survey of the approximately 2.27 acres of site 33WE0085 that intersect the Project's LOD (Survey Area). The purpose of the survey is to relocate any portions of site 33WE0085 that may remain intact within the Survey Area and to make recommendations as to the need for further work or avoidance of the site.

The Phase I archaeological survey was conducted in January and February 2024. A total of 45 shovel test pits (STPs) were excavated within the Survey Area. Shovel testing recovered four (4) prehistoric artifacts and identified one (1) potential cultural feature within the Survey Area in an area bisected by the existing pipeline.

The Phase I archaeological survey was conducted according to the Ohio Historic Preservation Office's (OHPO's) *Archaeological Guidelines* (OHPO 2022) by personnel that meet or exceed the Secretary of the Interior's Professional Qualification Standards (36 CFR Part 61) for conducting archaeological research. Mr. James T. Marine, MS/RPA served as the Principal Investigator and geomorphologist for the Project. The fieldwork was conducted by Mr. Troy Linebaugh, MA and Mr. Ryan Oergel, MA.



## 2.0 Environmental Setting

### 2.1 Physiography and Geology

The Survey Area is located in the Glaciated Allegheny Plateaus section of the Appalachian Plateau physiographic region. More specifically the Survey Area is situated within the Killbuck-Glaciated Pittsburgh Plateaus subsection of the Glaciated Allegheny Plateaus section. This subsection is characterized by ridges and flat uplands covered in a thin mantle of Wisconsin-age glacial drift. The uplands are typically dissected by steep valleys that vary from narrow, rock lined valley walls to broad, drift filled valleys (Brockman 1998).

The Survey Area is underlain by the Logan and Cuyahoga Formations of Mississippian Period. This formation is composed of interbedded shale with minor components of siltstone and major components of sandstone (Slucher et al. 2006).

### 2.2 Soils

A review of the United States Department of Agriculture-Natural Resources Conservation Service (USDA-NRCS) web soil survey identified three (3) soil types within the Survey Area (USDA-NRCS 2024). The Survey Area is predominantly underlain by Tioga silt loam, occasionally flooded (Tg), with smaller areas mapped across Bogart Loam, 2 to 6 percent slopes (Btb) and Lobdell silt loam, occasionally flooded (Le) (*NRCS Mapped Soils in Survey Area, Appendix A, Figure 4*). Tioga and Lobdell series soils are both composed of deep, moderately well drained to well drained alluvium. Tioga series soils exhibit a typical pedogenic sequence of Ap/Bw1/Bw2/C while Lobdell series soils typically exhibit a sequence of A/Bw/BC/Cg1/Cg2 (USDA-NRCS 2024). Bogart series soils are deep, moderately well drained soils formed in stratified glacial outwash deposits, outwash plains, and remnant beach ridges and exhibit a typical pedogenic sequence of Ap1/Ap2/Bt1/Bt2/Bt3/BC/C (USDA-NRCS 2024).

### 2.3 Pleistocene and Holocene Paleoenvironment

The Pleistocene Epoch witnessed a series of cold periods and associated "ice ages," the most recent of which terminated approximately 14,000 to 12,000 years before present (BP). One of the most dramatic effects of these "ice ages" was the lowering of ocean levels worldwide as rainwater was frozen and trapped in glaciers and continental ice sheets. Milliman and Emery (1968) argued on the basis of 80 radiocarbon samples taken along the Atlantic continental shelf that sea levels 30,000 to

35,000 years BP were close to those at present. Sea levels dropped subsequently as much as 130 meters during the final glaciation circa (c.) 16,000 years BP. Along the Atlantic coast, ocean beaches lay at the edge of the modern continental shelf, perhaps 100 kilometers (km) (62.1 miles [mi]) east of the current New Jersey coastline. Belknap and Kraft (1977) questioned the maximum depth of sea level drop but agreed with the overall temporal trends.

In the glaciated portions of Ohio, the ebb and flow of glacial advancement and retreat are noted by series or morainal features interspersed with interglacial lakes. At the end of the Pleistocene, c. 12,000 to 10,000 years BP, the Great Lakes began to form from glacial meltwater, and the regional network of drainages began to establish. At this time, the region was covered with conifer forests dominated by spruce, fir, tamarack, cedar, hemlock, and larch (Hansen 1995). As the climate began to warm at the end of the Pleistocene, the coniferous forests in Ohio were quickly displaced by deciduous forests, typically dominated by species of oak, similar to that of today's forests (Hansen 1995).

Evidence suggests that faunal resources were diverse during the early Holocene, including both those adapted to boreal and deciduous forests (Delcourt and Delcourt 1986; Eisenberg 1978). Guilday et al. (1977) note that the distribution of fauna depended on biotic gradients related to variations in topographic and edaphic conditions. Eisenberg (1978) cites evidence of mammoth and white-tailed deer co-occurring in the Northeast. The temperate forest faunal remains and pollen dating to c. 11,300 years BP at Meadowcroft may have been the localized result of favorable temperature and moisture regimes within the Cross Creek drainage (Adovasio et al. 1985).

There is evidence to suggest that the period between 9,000 and 5,500 years BP was characterized by a climate warmer and drier than present. Evidence for this Hypsithermal Period is strong in the Midwest where pollen data show an advance of the prairie eastward into Illinois, reaching its maximum extent at about 7,000 years BP (Bartlein et al. 1984; King 1980). In the eastern United States, evidence for a warmer, drier period at this time includes a peak in grasses at Bear Meadows in Centre County, Pennsylvania (Kovar 1965), and xeric vegetation on the Cumberland Plateau in Tennessee (Delcourt 1979). Davis et al. (1980) point to an increase in the altitudinal range of hemlock and white pine as evidence of a warmer, drier period between 9,000 and 5,000 years BP in New England. Watts (1979), in his examination of pollen diagrams in the Middle Atlantic region, supports the hypothesis of a warmer, drier climate between 8,500 and 5,500 years BP.

Effects of the warmer, drier climate included a decrease in the number of low-order streams, lower water volume in streams generally, a decrease in biomass on ridges, and a lowering of the water table (Graetzer 1986; Watts 1983). Evidence provided by correlations of pollen core data with pollen from surface samples from known vegetation types suggests that the overall composition of the vegetation did not change radically (Bradstreet and Davis 1975). However, changes in hydrology and decreases in productivity would likely have had some effect on the distribution of prehistoric populations. Specifically, upland areas would have become relatively less attractive, whereas major riverine areas such as floodplains and terraces would have been relatively more attractive.

By 5,000 years BP, a relatively stable primary forest was established in the region leading to today's classification of the Project area as part of the Southern Great Lakes lowland forests ecoregion within the greater temperate broadleaf and mixed forest ecoregion (Noss 2023). This region is characterized by a dominance of deciduous forests and contains a relatively low level of species diversification. While little forest remains in the region due to extensive agricultural use, historically the region's forests contained up to 80 percent sugar maple and beech with stands of oak and hickory in drier areas of the region (Noss 2023). Extensive historic draining of wetlands and clearing of forest land in the Project area has significantly altered the natural landscape in the past 200 years.

## **3.0 Cultural Context**

### **3.1 Prehistoric Context**

#### **3.1.1 Paleoindian Period (11,500 to 10,000 years BP)**

The Paleoindian period is the earliest documented occupation in the Ohio region and the Eastern U.S. This period is defined by distinctive cultural adaptations focused on the environmental milieu that characterized the late Pleistocene and early Holocene climatic periods. The key artifact type that identifies this period is the fluted projectile point, usually manufactured from a high quality crypto-crystalline lithic material, e.g., jasper, chert, or chalcedony. Although the Paleoindian stage is of short duration, three (3) distinct Paleoindian sub-phases or periods have been proposed by Gardner for this period in the Middle Atlantic region, based on excavations at the Thunderbird site complex in the Shenandoah Valley of Virginia (Gardner 1974), a periodization that is relevant to the Ohio region as well. Gardner's three-part subdivision of the Paleoindian stage was, in part, based on stratigraphic excavations at the Thunderbird site (Gardner 1974) though it had precedent in earlier work conducted in Nova Scotia. Gardner noted that MacDonald had subdivided the Paleoindian stage into three (3) separate phases based on his work with the Debert site materials in Nova Scotia (Gardner 1974; MacDonald 1968). MacDonald's Early Phase included only the Clovis points in his sequence. The second phase was defined by Folsom points and their cognate variants, while the Dalton-Hardaway sub-phase is the final chronological period of the Paleoindian stage, characterized by the minimally fluted Dalton and Hardaway projectile points. Many other tool categories are associated with these projectile points that usually cannot be taken by themselves as diagnostic Paleoindian indicators. It is notable that Tankersley (1996; see also Jefferies 2008) has also outlined a three sub-period sequence for the Lower Ohio River Valley, one that follows Gardner's chronological subdivisions of the Paleoindian stage and the sub-phases that he identified within it (Jefferies 2008:69–87; Tankersley 1996).

An analysis of fluted point distributions in Ohio suggests that Paleoindian site locations frequently are found in major stream valleys and at stream confluences close to quality flint resources. In Virginia, Gardner's (1974) quarry base camp model is applicable to a variety of geographic settings that includes Ohio, a model that Goodyear (1979) adopted for the Carolina region. As an example of this model, it is common that many diagnostic Paleoindian points have been recovered far removed from



the original lithic source from which they were made. One (1) of the lamellar blades associated with the Clovis occupation at Big Bone Lick in northern Kentucky was, as noted by Tankersley et al. (2009), struck from a core of Fort Payne chert, a source that is nearly 420 km (261 mi) distant from the site where it was recovered. Recovery of this lithic material far from its source reflects the high mobility of Early Paleoindian hunting groups. In addition, many points recovered distant from the quarry source exhibit curation or re-sharpening to preserve its useful life rather than selecting local lithic sources. Paleoindian sites are rarely documented in regions such as swampy lowlands or rugged highlands (Payne 1987) though the location of some upland Clovis point finds suggests that some use was made of these environmental settings. In particular, the Three Saylor's site in Harlan County, Kentucky contained a moderate-sized Clovis component situated on a terrace along a small tributary of the Kentucky River (Tankersley 2008). Based on the sourcing of lithic material recovered at Paleoindian sites in northern Ohio, Stothers et al. (2001) hypothesize that two (2) parallel waves of immigration into northern Ohio from southern and central Ohio occurred during the Paleoindian and Early Archaic periods.

Paleoindian groups relied on late Pleistocene faunal and floral resources for subsistence. In terms of faunal remains, there are several sites that have good associations of extinct faunal specimens and Clovis tools in direct association in the region. This sample would include the well-known Big Bone Lick site in Boone County, Kentucky, where late Pleistocene fauna, including numerous mastodon remains, have been recovered since the beginning of the nineteenth century. Tankersley et al. (2009) reported on the association and dating of stratigraphic contexts at the site that contain Clovis points along with mastodon and other extinct mammalian species that were present during the late Pleistocene era. Although there is no direct evidence that the faunal remains reflect game that was actually procured through hunting, the stratigraphic contexts of the site clearly illustrate the association of Clovis with mastodon remains. Excavations at Sheridan Cave site in northwest Ohio revealed an association between a single Clovis point and extinct mammalian species. Radiocarbon dating of one (1) of two (2) bone points recovered from the same stratigraphic context as the Clovis point fragment produced a date of 10,915 years BP. Calibrated, this date falls between 12,925 and 13,000 BP (Waters et al. 2009:109), a date that is well within the range for Clovis and the Early Paleoindian sub-phase or period. It is likely that such patterns of faunal exploitation continued into the later phases of the Paleoindian stage, though sites with good contexts are rare to non-existent in the area.

### **3.1.2 Early Archaic Period (10,000 to 8,000 years BP)**

The Early Archaic period was a technological and adaptive continuum from the Paleoindian period. It also marked the advent of a different “stage” of cultural development following the chronological scheme discussed above (Griffin 1967; Willey and Phillips 1958). Across the Eastern United States, projectile point assemblages exhibited a distinctive innovation in lithic technology not found in the earlier Paleoindian periods, the notching of projectile points, a trait that Gardner (1974) argued reflected the spear-thrower used with lances bearing points fixed on detachable shafts mounted on longer shafts or lances. Gardner argued that this may have been linked to the adoption of a throwing technique as opposed to a thrusting technique in hunting behavior, a change that may reflect an adaptation to the procurement of more solitary game species that were present in the changing environmental conditions that began towards the close of the Paleoindian period and accelerated during the onset of the Holocene climatic era and the Early Archaic period. A continuing climatic change post-dating the glacial recession led to the gradual reduction of the mixed open grassland biome and spruce forest characteristic of the Late Pleistocene. This change was coupled with the spread of a mixed deciduous forest biome (Carbone 1974) and in places, particularly in the Southeastern U.S., a more open grassland or savanna type environment.

Development of the deciduous forest probably led to the greater dispersal of game species that were hunted during the Early Archaic period. Following Gardner’s suggestion and based on their extensive work at the Haw River sites in North Carolina, Claggett and Cable (1982) argued that changes in biface technology from the earlier Paleoindian period reflected adaptations to a range of new environments that were the consequence of post-glacial warming trends (Sassaman et al. 1990:9). Such changes are readily seen in the Early Archaic assemblages found in Ohio.

Key projectile points that mark the onset of the Early Archaic period include the classic corner-notched Palmer and Kirk points and their cognate forms (Chapman 1985; Coe 1964; Gardner 1974). In his classic, well-known volume on the Carolina Piedmont, Coe suggested that the corner-notched Palmer point developed from the late Paleoindian Hardaway side-notched types (Coe 1964). Palmer points frequently exhibit basal grinding, a trait found on many Paleoindian specimens. This may represent a carry-over in preparation techniques of the haft prior to mounting the point in a shaft along with other aspects of Early Archaic lithic technology. As noted below, basal grinding was a variable trait and not

necessarily a good chronological indicator (Kimball 1996). Many specimens from West Virginia exhibit heavily ground basal elements, likely tied to techniques of lashing a finished point to a haft.

At the outset of the Early Archaic period, lithic technology saw the continued emphasis on the selection of high quality lithic raw materials employed during the Paleoindian period, especially during the Palmer sub-phase. Such a strong emphasis on the selection and use of cryptocrystalline lithic material for projectile point manufacture could suggest that a continuation of the quarry-base camp settlement model defined by Gardner (1974) and discussed further by Goodyear (1979) was still in use. Such a model may have been tied to mobility patterns related to the procurement of more solitary game species as well. A greater range of lithic raw materials appears to have been employed in the later Kirk phases and certainly by the onset of the Middle Archaic period.

Early Archaic settlement was likely timed to the distribution of faunal and floral resources that were being procured, and thus was distributed across a wider range of environmental zones than had been exploited previously when climatic conditions were different. For instance, to the south in eastern Tennessee, the Early Archaic sites along the Little Tennessee River are diverse in terms of resources exploited and include manos and metates for processing plant subsistence items. Such sites are called by Chapman (1985) “residential base camps” and are thought to mark larger social groups than those represented by small lithic scatters found in upland settings. The greater distribution of Early Archaic sites compared to the known extent and number of Paleoindian sites may reflect an adaptive pattern tied to dispersed or solitary roaming game species that were adapted to the gradually spreading deciduous forest. The greater number of Early Archaic sites is also testament to an increase in population over the Paleoindian period, if overall site density is used as a gross measure of population density.

In many sites, the Early Archaic components found in the larger river drainages, such as those identified by Prufer (1967) in the Scioto River Valley, were obscured by the intensive re-occupation of later Archaic and intense Woodland villages. Single-component residential base camps that yield better-defined Early Archaic diagnostic material have been located along the channels of smaller tributaries that were not used as frequently by later more sedentary Woodland components. The sites located along such smaller drainages have been interpreted as seasonal inland encampments (Pratt 1981). Evidence suggests that seasonal semi-sedentism began to develop around 9,000 BP; the

subsistence and settlement systems were characterized by scheduled exploitation of seasonally available resources and by a high degree of residential mobility within well-defined resource catchment areas (Muller 1986).

### **3.1.3 Middle Archaic Period (8,000 to 5,500 years BP)**

Characteristics that differentiate the Middle from the Early Archaic Period include a tool kit with groundstone grooved axes, bannerstones, bell-shaped pestles, and pendants; a decline in unifacially worked tools; and a shift in subsistence strategy to a heavier reliance on shellfish collecting along major drainages (Griffin 1967; Mayer-Oakes 1955). Numerous sites with Middle Archaic components also were identified during Prufer's (1967) survey of the Scioto and Hocking River valleys. Middle Archaic sites seem to be concentrated along the smaller tributaries.

The three (3) general types of Middle Archaic sites suggested by DeRegnaucourt (1983) are small camps, large camps, and base camps. "Small camps" usually are less than 0.5 hectare (1.24 acres) in area, probably were occupied from one (1) to a few days, and usually occur in upland areas away from streams on elevated ridges near springs. The category of "large camps" incorporates hunting camps, hunting, and butchering camps, and chert quarrying and processing sites. These sites are consistent with encampments of one (1) day to perhaps a week or slightly more; they typically occupy an area of between 0.5 and 2 hectares (1.24 to 4.94 acres). Base camps may be considered to represent the foci of a centrally based transhumance system and probably were occupied seasonally. Base camps range from 0.5 to 8 hectares (1.24 to 19.8 acres) in size and are located on prominent terraces, bluffs, or other elevations near the confluence of two (2) small streams or a small stream and a larger river. The basic projectile point types for the Middle Archaic are the Lecroy Bifurcate (7,500 years BP), the Eva basal notched (7,200 to 6,000 years BP), and the Morrow Mountain (6,700 to 6,400 years BP).

### **3.1.4 Late Archaic Period (3,500 to 1,000 years BP)**

The Late Archaic saw the advent of modern mixed deciduous forest communities throughout the northeastern United States. A hunting, fishing, and gathering economy developed around a seasonal schedule of resource procurement focused on white-tailed deer, nuts, waterfowl, fish, and mussels. Other economic functions and patterns also coincided with the scheduling of resources; bands or



tribes settled either in seasonal base camps or in one (1) semi-sedentary settlement with several satellite procurement stations distributed radially around them (DeRegnaucourt 1986).

In Ohio, six (6) site types occur: villages, camp sites, lithic scatters, find spots, rockshelters, and mortuary sites. The preference for habitation in all categories was for upland localities, particularly at the confluences of drainages, regardless of type of landform. The primary Late Archaic artifact types are the stemmed and notched projectile point forms such as Lamoka, Dustin, Brewerton side-notched, Brewerton corner-notched, Newton Falls side-notched, Susquehanna/Ashtabula, and Narrow stemmed types. Less frequently found are hafted scrapers, knives, drills and perforators, ground stone axes, celts, grooved hammerstones, adzes, and pestles. An extensive bone and antler industry is evidenced by such forms as bone fishhooks, bone awls, bone bodkins, hairpins, atlatl handles, antler points, and flakes, although it is probable that similar industries existed earlier (DeRegnaucourt 1986). Other characteristics of the Late Archaic included the first appearance of ceremonial paraphernalia, and the first real signs of collective cemeteries located away from settlement areas also were established (Penny 1985).

### **3.1.5 Transitional Period (3,000 to 2,000 years BP)**

The Transitional Period can be viewed as a stage during which numerous small societies shared a fundamental cultural package and interacted with mutually influential, more complex neighboring societies (Mason 1981). By 2,600 years BP, however, Early Woodland ceramic technology was firmly established throughout the region, ending the Transitional phase. Transitional sites that include habitation centers and ceremonial mounds are located in a wider variety of ecological settings, including upland terraces along smaller tributary streams (Abrams 1992). This pattern of site distribution seems to reflect a growing Adena influence that was grafted onto an Archaic-style framework of site location preferences. As mound-building became more prevalent, the variation in the ecological settings of sites narrowed, with nearly all sites located on the broad floodplains of major rivers (Abrams 1992).

Several types of projectile points are associated with the Transitional Period. Meadowood points, thin, triangular, well-made bifaces with small side notches, generally are crafted from Onondaga chert. Leimbach stemmed points are ovate based, tapered and straight stemmed bifaces. The other two (2) types are the large Feeheley bifaces, and the various small, micro-regional projectile point types of

which the Crawford Knoll type is the most common in northern Ohio. Cresap points are larger, stemmed bifaces that are believed to be a possible antecedent to later stemmed Adena projectile points (Shane 1967). Other artifacts that are diagnostic of the Transitional Period are stone bowls, birdstones, and smoking pipes (Mason 1981; Stothers and Abel 1993).

### **3.1.6 Early Woodland Period (2,600 to 2,100 years BP)**

Early Woodland in Ohio is defined primarily with reference to the Adena Culture of central and southern Ohio, which in turn is divided into the Early Adena (3,000 to 2,500 years BP), Late Adena (2,500 to 2,100 years BP), and Transitional Adena-Hopewell (2,100 to 1,900 years BP) sub-periods (Greber 1983). Specific Adena traits include: conical mounds located within earthen enclosures or constructed over burned dwellings; sacred circles with interior ditches; log tombs; circular houses with paired posts; and artifacts such as stemmed projectile points (especially the Robbins type), Adena Plain ceramics, expanded center gorgets, tubular tobacco pipes, hematite cones, galena artifacts, mica artifacts, use of ornamental copper, jaw spatulas, scapula awls, tablets with stylistic engravings, and sculpture in the round (Kime 1986).

Early Woodland social organization adopted a hierarchical system that drew together groups on at least three (3) social levels: regional bands, local bands, and band segments. Several types of Early Woodland sites are common throughout the region. Village sites accommodated large groups of more than five (5) households as year-round primary domiciles; they frequently were occupied for more than one (1) year, and they provide evidence of permanent structures. Camps were short-term seasonal occupation sites with structural remains or were used for other special purpose activities. Mortuary sites contain one (1) or more burials in non-mound contexts, as at the Caldwell's Little Bluff Site (Lovejoy 1967). Mounds are earth and stone deposits placed over one (1) or more burials. Earthworks consist of earthen walls arranged in geometric patterns.

### **3.1.7 Middle Woodland Period (2,100 to 1,500 years BP)**

The Middle Woodland has been defined primarily with reference to the Hopewell culture. Ohio Hopewell culture was based primarily in the Ohio and Scioto river valleys and does not appear to extend in northern Ohio (Bush 1978). The Hopewell cultural phenomenon is defined by the exchange of rare ritual items rather than by local phases. Sizable populations were present, but truly large-scale agriculture was not practiced. Hopewell sites elaborated on Early Woodland models; their larger

earthworks and richer burials suggest intensified ceremonialism and greater social inequality. Specific Hopewell traits include enclosure, burial, and effigy mounds and earthworks; distinctive dentate-stamped and rocker-stamped ceramic vessels; platform pipes; cut animal jaws and teeth; pan pipes; extensive villages located near water sources; and widespread long-distance exchange networks (Fitting 1978).

Maslowski and Seeman (1992) identified five (5) ecological zones for Hopewell habitation, including stream channel, flood zone, Wisconsin terraces, Illinoian terraces, and uplands. The primary Hopewell settlement pattern consisted of small farmsteads scattered around ceremonial centers (Fitting 1978), although the exact relationship between these two (2) types of sites is still debated (Dancey and Pacheco 1997). Mound sites have been interpreted as communal hubs of trade, redistribution, and shared ceremonial events (Dancey and Pacheco 1997).

### **3.1.8 Late Woodland Period (1,500 to 800 years BP)**

The Late Woodland Period was marked by the gradual disappearance of Hopewell influences and by a gradual contraction of the inter-regional exchange of raw materials and finished artifacts (Griffin 1943). In terms of settlement patterning, Dancey (1992), in his comparison of Middle and Late Woodland settlement patterns, noted that the size of Late Woodland habitation sites was 2 to 4 hectares (4.94 to 9.88 acres), a marked increase from the previous average size of 0.6 to 2 hectares (1.48 to 4.94 acres) during the Middle Woodland. The Late Woodland populations inhabited rock shelters in the Allegheny Plateau, floodplains along the Ohio River, and the flat open terrain associated with the glaciated areas of northern Ohio (Prufer and McKenzie 1966).

Projectile point styles from the Late Woodland period in Ohio most often associated with bow and arrow technology are the Jack's Reef Corner Notched, Raccoon Notched, Hamilton, and Levanna types. Thomas (1978) has put forth a quantitative analysis of the relative size of dart and arrow points, and according to his data only Madison triangular points (1,100 to 500 years BP) qualify as true arrow points. Dates associated with Madison points may demonstrate a widespread acceptance of bow and arrow technology, with a "trial use" period from 1,400 to 1,200 BP, marked by some of the most pronounced changes in projectile point morphology in the Woodland period (Seeman 1992).

### **3.1.9 Late Prehistoric Period (800 to 350 years BP)**

The Late Prehistoric period within the Muskingum drainage is represented by the Philo phase. The groups associated with the Philo phase shared traits with the Monongahela culture of eastern Ohio and Pennsylvania, and with Fort Ancient groups to the south (Carskadden and Morton 1977). To the west along the Scioto River were Fort Ancient groups. Both the Fort Ancient and Philo groups exhibit patterns of procurement and settlement patterns different from those of their Late Woodland predecessors. The Fort Ancient subsistence economy was centered around maize agriculture, with some growing of beans and squash. Both hunting and gathering supplemented the economy (Essenpreis 1978). Settlements were occupied year-round and were concentrated along the major rivers. They were typically large, stable villages, often organized around a central plaza. Houses were round, oval, or rectangular (Essenpreis 1978). In some cases, a circular palisade was associated with the village.

The Great Lakes area shows a decreased influence of Fort Ancient or Philo phase characteristics. Settlement patterns tended to be small, dispersed populations that practiced a mixed agricultural and hunter-gatherer economy. Large villages were located on promontories along the main rivers 2.4 km to 32 km (1.5 mi to 20 mi) from Lake Erie and appear to represent summer and early fall occupation. Agriculture was limited to the floodplains and adjacent terraces. During the late fall and winter, these villages were supported by family hunting camps or adjacent promontories with elk and bear hunting and nut collection as the major activities. In the early spring, these villages split into small multi-family groups that occupied camps along the bluffs and beaches at the mouths of rivers or on the shores of Lake Erie, exploiting fish and waterfowl as the major food source (Jackson and Harris 1992). Faunal assemblages from excavated Monongahela and Philo sites indicate extensive exploitation of deer as well as elk and turtle (Brown 1981; Carskadden and Morton 1977). While corn has been found at sites from both cultural groups, it occurs in a lower frequency when compared to Fort Ancient sites.

Around 450 BP, Late Prehistoric groups in western Pennsylvania procured materials which indicate an indirect contact with European settlers (Herbstritt 1983). These materials include wire-wound faceted beads, copper tinklers, and native-manufactured artifacts such as triangular glass and metal pendants made from imported European goods. In contrast to later sites, there is no change in intra-site patterning of subsistence procurement strategy. Recognition of protohistoric sites is based solely on



the occasional occurrence of European trade items (Skinner and Brose 1985). This influx of trade items is documented in the Middle Ohio Valley ca. 350 to 250 BP at two (2) contact period sites in Greenup County, Kentucky (Pollack and Henderson 1983). The difficulty in recognizing these sites, given the limited change in the material culture, undoubtedly has resulted in the lack of proper protohistoric designations. Throughout this period, northeast Ohio was only sparsely populated by transient aboriginal populations, often geographically and culturally displaced from other areas (Jackson and Harris 1992).

## **3.2 Historic Context**

### **3.2.1 Frontier (ca. 1775–1795)**

Until the late eighteenth century, few Euro-Americans had settled in Ohio. Those who were in Ohio either lived in or near Native American villages or were hunter-farmers. During the Revolutionary War, squatters from western Pennsylvania and Virginia began occupying land in what would become eastern Ohio. By 1779, there were clearances along the Ohio River as far south as the Muskingum River. In 1785, there were approximately 300 families at the falls of the Hocking River, 300 along the Muskingum River, and 1,500 along the Miami and the Scioto rivers (Jones 1983). These small settlements would have been rather perilous because they were not welcomed by the Native Americans, nor were these settlements sanctioned by the United States government. The descendants of these first migrants to Ohio probably formed the core of native-born Ohioans in northeast Ohio.

### **3.2.2 Settlement (1796–1819)**

The Treaty of Greenville, signed August 3, 1795, was the impetus for rapid settlement of Ohio. Previously, Ohio pioneers, like pioneers of New England, had settled in defensible nucleated groups with in-lots and out-lots for mutual protection. Following the conflicts with Native Americans during 1794 and the establishment of the Greenville Treaty line in 1795, much of modern day Ohio was subsumed into the newly formed United States became safer for isolated farms in these regions (Bond 1941).

Migrants to Ohio at first gravitated toward the Virginia Military District, the Symmes Purchase, and the Ohio Company Purchase. These areas were held privately and were already open for settlement. The

Survey of the Seven Ranges (1785–1786) and the Connecticut Western Reserve greatly increased the available land (Bond 1941). Settlement of Northeast Ohio was essentially the result of migration from Mid-Atlantic states, especially Pennsylvania and Maryland. Settlers from this area moved westward, crossing the Ohio River, and following its tributaries, or early traces, inland.

Most migrants were farmers seeking fertile farmland in the new frontier. Their livelihood depended on livestock raising and grain production, particularly wheat (Wilhelm 1982). Although new settlers, out of necessity, were self-sufficient, they still had to trade for basic supplies such as coffee, tea, salt, sugar, hardware, farm implements, and cloth. The average settler cleared only 2.47 acres of land per year. Generally, the early farmer only put a small portion of land (about 9.88 acres) for crops under the plow and reserved plenty for pasture for animals and forest for firewood and livestock, usually pigs. However, to produce much more than his family needed would have been pointless as roads were not adequate to get their goods to market. Any surplus produce was used to trade for supplies or was distilled (Heald 1949; Noble and Wilhelm 1995).

The land comprising northeast Ohio was not ceded to the United States until the early nineteenth century through a succession of land treaties. The former Native American trails through the region aided in establishing frontier settlements (Blue 1928). The region's counties, known for their rich, agricultural lands, became great wheat producers and, by 1815, were the center of an exclusively sheep-raising, agricultural region (Howe 1902). Coal-mining activity in the region has a history extending back to 1806. Ten (10) years later, coal was the chief source of fuel in these counties (Perrin 1881).

### **3.2.3 Immigration**

Little immigration occurred in the first decade-and-a-half of the nineteenth century, due to the disturbance of shipping caused by the Napoleonic Wars and the War of 1812. After peace was achieved by 1815, transatlantic shipping resumed. With a change in European land policies of the nineteenth century, emigration was also encouraged or viewed as the only viable option by European peasants (Wilhelm 1982).

Immigrants from Ireland, Scotland, and Germany left their homelands due in part to changing land policies. When the potato crops failed, most notably in Scotland in 1846 and in Ireland ca. 1830 to

1845, there was a massive wave of emigration from those countries. Many Germans left their homeland after the failed Revolution of 1848. These nineteenth-century German immigrants often joined and reinforced the cultural ways of the westward-moving Pennsylvania Dutch, descendants of eighteenth-century German immigrants (Wilhelm 1982).

Diverse social, economic, political, and material traits became established in northeast Ohio because of the varying cultural backgrounds of the migrants. Since the major migrant groups became geographically distinct during settlement and did not overlap greatly, their respective cultural influences remained relatively unchanged and persistent, providing the basis of the region's cultural differentiation of today (Wilhelm 1982).

The 1850 census of Ohio is a good indicator of the ethnic and regional composition of the state in the middle of the nineteenth century, after the initial settlement and predominantly western European immigration, and before the largely eastern European immigration in the late nineteenth and early twentieth centuries (Wilhelm 1982). All of these groups probably shared a similar cultural background, that of Germanic/Pennsylvania Dutch. Judging by the sheer number of Pennsylvanian migrants, the Marylanders were probably from parts of Maryland strongly influenced and dominated by Pennsylvania culture. Likewise, the number of German immigrants indicates that the French were probably from parts of France strongly influenced and dominated by Germanic culture. Thus, a Germanic influence would be expected to dominate much of northeast Ohio due to the sheer numbers of the migrants from the Pennsylvania sphere, combined with the immigrants from the German sphere.

### **3.2.4 The Industrial Period (ca. 1850–1930)**

An investment in infrastructure complemented Ohio's central location and put it at the heart of the nation's transportation system traveling north, south, east, and west, and also gave northeast Ohio a head start during the national industrialization process which occurred during this period. By the late 1810s, the National Road crossed the Appalachian Mountains, connecting the region with the east coast. The Ohio River aided the agricultural economy by allowing farmers to move their goods by water to the southern states and the port of New Orleans. The construction of the Erie Canal in the 1820s allowed businesses to ship their goods through Lake Erie and to the east coast, which was followed by the completion of the Ohio and Erie Canal and the connection of Lake Erie with the Ohio

River. This gave the region complete water access to the world within the borders of the United States. The Ohio Loan Law of 1837 allowed the state to loan one-third of construction costs to businesses, passed initially to aid the construction of canals, but instead used heavily for the construction of railroads. The Baltimore and Ohio Railroad crossed the Appalachians in the mid-1850s and connected the state with the east coast (Heald 1949).

Wooster, in Wayne County, was one (1) such city which benefited from its proximity to transportation resources, first from the construction of the Ohio and Erie Canal in 1827, followed by the development of the Ohio & Pennsylvania Railroad in the 1850s, and eventually the construction of the Lincoln highway through Wooster in the early twentieth century. The varied transportation routes developed through this period allowed the export of regionally produced goods and materials but also attracted the development of supporting commerce and industry into the region. With the emergence of a successful and growing industrial base in the region, the need for workers was high and the increase in population created a need for more housing (Heald 1949).

### **3.2.5 Mid-Twentieth Century (1930–1960)**

From the time Ohio attained statehood in 1803, the state's ready access to raw materials and navigable waterways at its northern and southern boundaries offered industrious entrepreneurs the opportunity for profit. With an abundance of coal and iron ore, industrialists throughout the state erected iron works for the production of pig iron. The Mahoning Valley, in northeast Ohio, developed into a significant iron smelting area. The iron industry in turn facilitated development of a large steel industry, with Youngstown in the Mahoning Valley arising as one of the most prominent steel towns in the country (Hunker 1958).

During World War II, the region experienced significant industrial development and population growth. The state's diversified industrial base and geographical proximity to transportation routes and other population centers made it well suited for wartime production needs. The industrial development and consequential economic prosperity generated during World War II shaped the region's economic, cultural, and social history for decades thereafter.

As the development of paved roads and automobiles accompanied this industrial development, demographic trends shifted from population increases in the cities at the expense of the countryside,



to the opposite trend. The population of both the county and cities continued to grow, but the population living in the cities dropped to 59 percent, meaning the non-city population grew more quickly than the city population by that time. The suburban areas by 1958 had more residents than any single city in the region. Early suburban development in the post-World War I period had focused on subdivisions for the wealthy. In the post-World War II period, suburban living for city workers became the rule rather than the exception (Heald 1958).

The agricultural sector of the region's economy also benefitted from wartime expansion and demand. Northeast Ohio farmers worked within a constantly changing dynamic that involved weather, market forces, and technological developments. A farmer's success often depended on his or her acumen at correctly assessing both current events and future trends. At the onset of World War II, the region's farmers faced numerous difficult challenges, many of which had been brewing for more than two (2) decades. Small and family farms met additional obstacles as most federal government programs were tailored toward consolidating farms and meeting the needs of large farmers. The resultant industrialization of agriculture that began during this period continued through the remainder of the twentieth century (Hunker 1958).

### **3.2.6 Late-Twentieth and Early-Twenty-First Centuries (1960-present day)**

Wayne County has maintained its rural character into the twentieth century. The county serves as the leading dairy producing county in Ohio and is home to the Ohio Agricultural Research and Development Center, the country's largest ag-biosciences research facility. The primary employers within the county are involved in manufacturing with major companies such as the Wooster Brush Company, ArtiFlex, Schaeffler Group USA Inc. and The J.M. Smucker Company. Wayne County is also home to Wooster College, the University of Akron-Wayne Campus, and the Ohio State University College of Food Sciences which support numerous jobs in education and health services.

## 4.0 Methodology

### 4.1 Background Research Methods

Preliminary research was initiated by reviewing the archaeological and historical architecture files and relevant cultural resource management reports using cultural resources data provided by the OHPO. Previously recorded cultural resources within 1.6 km (1 mile) (Desktop Study Area [DSA]) of the Project were identified and mapped. A list of the sources consulted includes the following:

- OHPO Online Mapping website;
- NRHP files;
- Ohio Historic Inventory files;
- Ohio Historic Bridge Inventory files;
- Ohio Genealogical Society Cemetery files;
- Ohio Archaeological Inventory (OAI) files;
- *Mills' Archaeological Atlas of Ohio* (1914);
- Cultural Resource Management reports;
- County atlases and plat maps;
- United States Geological Survey (USGS) 15' and 7.5' quadrangle maps; and
- Recent and historical aerial photographs.

Additional research was undertaken to develop prehistoric, historic, and environmental contexts. The cultural contexts included an assessment of the prehistory and history of the area and formed the foundation required for the interpretation and evaluation of archaeological sites identified during field investigations. Environmental research focused on aspects of local geology, soils, hydrology, geomorphology, vegetation, and recent natural and/or cultural disturbances to the Survey Area. Existing data and preliminary background research gathered during earlier studies were incorporated and utilized as appropriate to develop a predictive model that would guide fieldwork.

### 4.2 Field Methods

Surface visibility within the Survey Area did not meet the minimum threshold to conduct pedestrian survey. Subsurface investigations were completed through the excavation of shovel test pits (STPs). STPs were placed in a linear transect in 15-m (49.2-ft) intervals. As the transect followed an existing pipeline, STPs were offset as needed based on location of the previous disturbance. When historic alluvium lacking archaeological context was encountered near Apple Creek, testing intervals were extended to 30-m (98.4-ft). Each STP measured 50 x 50 centimeters (cm) (20 x 20 inches [in]) and was excavated to 80 cm (31.5 in) below surface or 10 cm (3.9 in) into sterile subsoil. The use of auger tests

(AT) was implemented judgmentally at the discretion of the Principal Investigator/Geomorphologist in the portions of the Survey Area mapped within alluvial soils. To determine the vertical extent of alluvial deposition within the Survey Area, a 10.2 cm (4-in) bucket auger was placed in the base of select STPs and excavated until reaching channel lag.

Excavated soils were sifted through ¼-inch hardware cloth. Where feasible, STPs were excavated by stratigraphic level and a description of each STP was recorded in the field on standardized forms. The description included the location of the STP within the sampling grid, and information pertaining to the local terrain, color, texture, composition, and thickness of soil strata as well as the presence or absence of cultural materials. After excavation and recordation STPs were backfilled. When artifacts were recovered, radial STPs were placed in cardinal directions at 5-m (16.4-ft) intervals surrounding the positive STP. Excavation of radial STPs continued until identifying two (2) consecutive negative STPs, disturbance, or the boundary of the Survey Area. The location of each STP and supporting field documentation was collected utilizing a handheld tablet running ESRI Field Maps software attached to a global navigation satellite system receiver antenna providing submeter accuracy.

### **4.3 Artifact Analysis and Curation**

Artifacts recovered during the investigation were temporarily stored in 3-milimeter polyethylene bags and tagged with corresponding provenience information. The artifacts were then transported to ECT's Northfield, Ohio laboratory to be cleaned and analyzed. Prehistoric lithics were classified according to type and material. Debitage was identified by raw material and tabulated according to basic debitage type. Following completion of the Project, artifacts will be returned to the landowner.

## 5.0 Results

### 5.1 Results of Background Research

At the time of the investigation, the OHPO Online Mapping System, the digital repository of cultural resources data maintained by the OHPO, was not available for public use. Spatial data for previously recorded cultural resources within the DSA of the Project was provided to ECT by the OHPO in February 2024.

ECT’s review of data provided by the OHPO identified four (4) previously completed Phase I archaeological surveys and one (1) Phase II archaeological site evaluation have been conducted within the DSA (*Previously Recorded Cultural Resources*, **Appendix A, Figure 5; Table 1**). No surveys were identified within the Survey Area though one (1) past survey, OHPO Log 969239, was completed south of Apple Creek, and intersects the Project where it parallels North Hillcrest Drive.

**Table 1. Previously Completed Cultural Resources Surveys within DSA**

OHPO LOG No.	Survey Phase	Year	Author(s)	Report Title
N/A	I	1981	Immel, Elsie A. and Julie Kime	Preliminary Survey of the Proposed Apple Creek Flood Control Project Near Wooster in Wayne County, Ohio
969239	I	1995	Bush, David R. et al.	Phase II Cultural Resource Investigation of the Proposed WAY-30-11.86 Project, Wayne County, Ohio.
969239	II	1997	Kollecker, Mark A., et al.	A Phase I and Phase II Cultural Resource Investigation of the Proposed WAY-30-11.86 Project, Wayne County, Ohio
982151	I	2000	Keener, Craig S.	Phase I Cultural Resource Management Survey of the Proposed 30.3 ha (75 a.) Development in Wooster Township, Wayne County, Ohio
1032144	I	2010	Zink, Justin	Phase I Archaeological Survey for the WAY-County Garage Project (PID 83203) in Wayne Township, Wayne County, Ohio

A total of 46 previously recorded archaeological sites were identified in the DSA (*Previously Recorded Cultural Resources*, **Appendix A, Figure 5; Table 2**). Limited information regarding these sites is included in the spatial data acquired from the OHPO. All of the sites contained a prehistoric component while one (1) site, 33WE0370, contained both a prehistoric and historic component. Fourteen (14) of the sites are recorded as isolated finds, one (1) site, 33WE0029, is recorded as a woodland period mound grouping while the remaining 31 sites are of an unknown type. No NRHP determinations were included in the OHPO spatial data. As a result, the NRHP status for all 46 sites is presently unknown though the isolated finds are assumed to be not eligible for listing in the NRHP. A



review of Mills' *Archaeological Atlas of Ohio* (1914) did not identify any archaeological sites or trails within the DSA.

**Table 2. Previously Recorded Archaeological Sites within the DSA.**

OAI Number	Site Name	Temporal Affiliation	Time Period	Site Type
WE0022	Sylvan Site	Prehistoric	Unassigned Prehistoric	Unknown
WE0028	Sigler Site	Prehistoric	Unassigned Prehistoric	Unknown
WE0029	Sigler Mound Group	Prehistoric	Unassigned Woodland	Mound Group
WE0038	Sigler-Morrison	Prehistoric	Late Archaic, Early Woodland	Unknown
WE0039	Sigler Site II	Prehistoric	Unassigned Prehistoric	Unknown
WE0040	Sigler Site III	Prehistoric	Unassigned Archaic	Unknown
WE0085	Taggart Farm Site	Prehistoric	Unassigned Prehistoric	Unknown
WE0086	N/A	Prehistoric	Unassigned Prehistoric	Unknown
WE0091	N/A	Prehistoric	Unassigned Prehistoric	Unknown
WE0271	N/A	Prehistoric	Unassigned Prehistoric	Isolated Find
WE0272	N/A	Prehistoric	Unassigned Prehistoric	Unknown
WE0273	N/A	Prehistoric	Unassigned Prehistoric	Unknown
WE0274	N/A	Prehistoric	Unassigned Woodland	Isolated Find
WE0275	N/A	Prehistoric	Unassigned Prehistoric	Unknown
WE0276	N/A	Prehistoric	Unassigned Prehistoric	Isolated Find
WE0277	N/A	Prehistoric	Unassigned Prehistoric	Unknown
WE0278	N/A	Prehistoric	Unassigned Prehistoric	Unknown
WE0279	N/A	Prehistoric	Unassigned Prehistoric	Isolated Find
WE0280	N/A	Prehistoric	Unassigned Prehistoric	Isolated Find
WE0281	N/A	Prehistoric	Unassigned Prehistoric	Unknown
WE0282	N/A	Prehistoric	Unassigned Prehistoric	Unknown
WE0287	N/A	Prehistoric	Unassigned Woodland	Unknown
WE0370	N/A	Prehistoric and Historic	Unassigned Prehistoric and Unassigned Historic	Unknown
WE0371	N/A	Prehistoric	Unassigned Prehistoric	Isolated Find
WE0372	N/A	Prehistoric	Unassigned Prehistoric	Isolated Find
WE0373	N/A	Prehistoric	Unassigned Prehistoric	Unknown
WE0374	N/A	Prehistoric	Unassigned Prehistoric	Unknown
WE0375	N/A	Prehistoric	Unassigned Prehistoric	Unknown
WE0376	N/A	Prehistoric	Unassigned Prehistoric	Unknown
WE0377	N/A	Prehistoric	Unassigned Prehistoric	Isolated Find
WE0378	N/A	Prehistoric	Unassigned Prehistoric	Unknown
WE0379	N/A	Prehistoric	Unassigned Prehistoric	Unknown
WE0448	N/A	Prehistoric	Unassigned Prehistoric	Unknown

OAI Number	Site Name	Temporal Affiliation	Time Period	Site Type
WE0449	N/A	Prehistoric	Unassigned Prehistoric	Isolated Find
WE0450	N/A	Prehistoric	Unassigned Prehistoric	Isolated Find
WE0451	N/A	Prehistoric	Unassigned Prehistoric	Unknown
WE0452	N/A	Prehistoric	Unassigned Archaic	Unknown
WE0468	N/A	Prehistoric	Unassigned Prehistoric	Unknown
WE0472	N/A	Prehistoric	Unassigned Prehistoric	Isolated Find
WE0473	N/A	Prehistoric	Unassigned Prehistoric	Isolated Find
WE0474	N/A	Prehistoric	Unassigned Prehistoric	Isolated Find
WE0475	N/A	Prehistoric	Unassigned Prehistoric	Unknown
WE0476	N/A	Prehistoric	Unassigned Prehistoric	Unknown
WE0477	N/A	Prehistoric	Unassigned Prehistoric	Unknown
WE0546	N/A	Prehistoric	Unassigned Prehistoric	Unknown
WE0547	N/A	Prehistoric	Unassigned Prehistoric	Isolated Find

As noted in the introduction to this report, site 33WE0085, the Taggart Farm site, intersects the Project on the north side of Apple Creek. The original site form indicates site 33WE0085 was originally identified through excavations by the landowner, D.W. Taggart, in 1960 though was not recorded with the OHPO until 1979. The form reports that Taggart uncovered charcoal, fire-cracked rock (FCR), chert debitage, and tools from the T2 and T3 terrace north of Apple Creek but the location of the site was not field checked. The site boundary as depicted in the site form encompasses an approximately 32-acre area north of Apple Creek on both sides of South Geyer Chapel Road (*Previously Recorded Cultural Resources, Appendix A, Figure 5*). The boundary is described in the OHPO data as highly problematic, and the extent of the site is approximate and unknown.

ECT identified 13 previously recorded above ground resources in the DSA (*Previously Recorded Cultural Resources, Appendix A, Figure 5, Table 3*). These resources consist of mostly single dwellings constructed between 1820 and 1960 but also include commercial and agricultural properties. No NRHP determinations were included in the spatial data provided by the OHPO for any of the above ground historic resources.

**Table 3. Previously Recorded Above Ground Resources in the DSA.**

OHPO No.	Name	Address	Date of Construction	Historic Use
WAY0006913	Jacob Kramer House	SW of US 30 & Honeytown Rd intersection	1840	Single Dwelling

OHPO No.	Name	Address	Date of Construction	Historic Use
WAY0025213	Lincoln Way East	3242 US 30	1920	Hotel/Inn/Motel/ Apartment House
WAY0029213	Weimer House	4752 US 30	1920	Single Dwelling
WAY0029313	N/A	4727 US 30	1890	Single Dwelling
WAY0029413	Abie Sigler	434 N Honeytown Rd	1960	Single Dwelling
WAY0029513	S Baker Farmstead	512 N Honeytown Rd	1830	Single Dwelling
WAY0029613	N/A	184 Geyer's Chapel Rd	1920	Single Dwelling
WAY0029713	Warren Sigler House/Samuel Rult Farmstead	314 N Geyer's Chapel Rd	1870	Single Dwelling/Agricultural
WAY0029913	N/A	147 Hillcrest Rd	1910	Single Dwelling
WAY0030013	William Pearce House/Riffel Dairy Farm	2795 Varian Rd	1840	Single Dwelling
WAY0030113	Wayne Holmes Heating & Refriger/Wertz/ Varian Orchard	2626 Varian Rd	1920	Food Storage/Commercial
WAY0030213	Gerald Eyster House	1853 Sylvan Rd	1870	Single Dwelling
WAY0030313	N/A	1571 Sylvan Rd	1900	Single Dwelling

## 5.2 Results of Fieldwork

Fieldwork was completed in late January and early February 2024 under seasonal conditions. The Survey Area extended across approximately 2.27 acres consisting of open agricultural field and forested wetlands along the north bank of Apple Creek (**Appendix B, Photos 1 and 2**). A total of 45 STPs, inclusive of 28 primary STPs and 17 radials STPs (*Results of Phase I Archaeological Survey, Appendix A, Figure 6*), were excavated during the investigation resulting in the recovery of four (4) artifacts and one (1) possible cultural feature.

The center of the proposed LOD is disturbed from the installation of the existing pipeline. Soil profiles encountered in STPs excavated during the investigation displayed variable rates of disturbance and a high degree of irregularity across the Survey Area based on the proximity to Apple Creek. The Apple Creek stream valley near the Survey Area is bounded to the south by a resistant ridge that rises approximately 9-m (29.5-ft) above Apple Creek (**Appendix B, Photo 3**) while the northern edge of the stream valley roughly follows the 920-ft contour line on the USGS topographic map (*USGS Topographic*

*Map, Appendix A, Figure 1*). This northern boundary is visible in aerial imagery as a faint scar across the open field and was noted in the field by the presence of a seep emerging from the bedding plane of shallowly buried sedimentary rock just north of the Survey Area (*Alluvial Terraces on 1960 Aerial Photograph, Appendix A, Figure 7*). From the active channel north towards the seep that marks the boundary between alluvial soils and the residual soils of the upland, a series of terraces becoming higher and older with distance from the active channel are visible as slight topographic rises. The T(0) terrace (active floodway) lies approximate 1.8 m (6 ft) above the pool level of the stream (**Appendix B, Photo 4**). Two (2) higher older terraces designated T(1) and T(2) are depicted in **Appendix A, Figure 7** and can be seen in **Appendix B, Photo 5**.

The alluvial deposits documented in the shovel tests indicate the stream channel has migrated laterally in a meandering fashion from the bedrock seep to its present position entrenched against the resistant ridge to the south. The lateral migration of the stream left behind a sheet of channel deposits that were too heavy to be moved in the stream's suspended load. These deposits referred to as channel lag consist of a sheet of water rounded gravel punctuated by gravel bars of varied heights and configurations. These lateral deposits were later covered with finer overbank flood deposits of sands and silt that emanated from the stream in its current position thus forming the current terraced topography.

STPs 1 through 4, between South Geyers Chapel Road and the edge of the Apple Creek floodplain, contained residual soils consistent with those mapped as Bogart Loam. Soil profiles in these STPs typically consisted of a grayish brown to brown (10YR 5/2 to 10YR 5/3) silt loam plowzone (Ap-horizon) underlain by a yellowish brown (10YR 5/6) to brownish yellow (10YR 6/6) Bt-horizon which in turn was underlain by a silt loam Cg horizon (Gley 1 3/N). STP 2 is representative (**Appendix C, Figure 1**).

STPs 5 through 17 were centrally located within the Survey Area across the T(1) and T(2) terraces north of Apple Creek and exhibited soils profiles exhibiting characteristics consistent with both the Lobdell and Tioga series soils mapped for the area. However, significant variability in the depth and continuity of the soils across the landform indicates the alluvial deposits underlying the T(1) and T(2) terraces are the product of the lateral migration of Apple Creek across the valley bottom, and that intact archaeological contexts are only found as discontinuous pockets. STPs 5 and 6 to the northeast and 10, 12, and 14 to the southwest exhibited a sequence of Ap/Bw1/Bw2-BC/C to depths extending up to



137 cm (38.2 and 53.9 in) below surface (**Appendix C, Figure 2**). Shallow gravel bars were identified on the north side of the existing pipeline in STP 8, its corresponding radials, and in STPs 15, 16, and 17 (**Appendix C, Figures 3, 4, and 5**). These STPs exhibited a soil profile consisting of a brown (10YR 3/3) silt loam Ap-horizon at depths between 20 and 40 cm (7.9 and in) below surface directly over channel lag or were underlain by a thin, dark yellowish brown (10YR 3/6) sandy loam BC horizon before reaching channel lag.

Soils identified on the T(1) terrace are best exhibited in STP 11 E5 where a dark brown (10YR 3/3) silt loam plowzone was identified above a dark yellowish brown (10YR 4/6) fine silt loam Bw-horizon. The Bw-horizon was underlain by a very dark gray (Gley 1 3/N) very fine sandy loam before reaching channel lag approximately 103 cm (40.5 in) below surface (**Appendix C, Figure 6**). The existing pipeline trench was identified in STP 11 N5 (**Appendix C, Figure 7**)

STP 22 marks the break between the T(1) terrace and the T(0) terrace. The profile in this STP exhibited an overburden composed of an admixture of dark brown (10YR 3/3) silt clay loam, a pale brown (10YR 5/4) silt loam, and a reddish brown (5YR 5/4) sandy loam overlying interfingering AC and Cg horizons. The AC-horizon consisted of a very dark grayish brown (2.5Y 3/2) massive sand while the Cg-horizon consisted of a dark gray (Gley 1 4/1) plastic sandy loam overlying channel lag at 114 cm (44.9 in) below surface (**Appendix C, Figure 8**)

STPs 18 through 21 and 24 through 28 were excavated in the forested areas along the T(0) and T(1) terraces north of Apple Creek and exhibited a layer of historical alluvium over channel lag. The historic alluvium was characterized as series of stacked C/AC horizons between the surface and the underlying channel lag (**Appendix C, Figure 9**). Occasional modern materials such as wire nails and beer bottles were noted in the historic alluvium but were discarded in the field.

#### **Site WE0085**

Two (2) primary STPs, 8 and 11, were positive for prehistoric cultural material within the Survey Area at site 33WE0085 (*Results of Phase I Archaeological Survey, Appendix A, Figure 6*). A single chert flake fragment was recovered from the plowzone of STP 8 on the north side of the existing pipeline. Radial excavations around STP 8 recovered one (1) tertiary chert flake and one (1) additional chert flake fragment from the plowzone of STPs 8 E5 and 8 E5N5 (**Appendix B, Photo 6**). The positive STPs were

bounded by double negative radials to the north and west and by the disturbance from the existing pipeline to the south and east (*Results of Phase I Archaeological Survey*, **Appendix A, Figure 6**).

STP 11 was excavated on the south side of the existing pipeline approximately 35 m (114.8 ft) southwest of STP 8 (*Results of Phase I Archaeological Survey*, **Appendix A, Figure 6**). A concentration of charcoal surrounded by darkened soil and fragments of FCR was uncovered at the interface of the plowzone and the underlying Bw-horizon at 27 cm (10.6 in) below surface (**Appendix B, Photo 7**). A chert core fragment/possible scraper was also recovered at the interface (**Appendix B, Photo 8**). The soil anomaly was not excavated and was reburied so as not to disturb a potential cultural feature. At this time, it is not presently clear if the anomaly is cultural in origin, but its presence is consistent with the site documentation indicating charcoal, FCR, and chert debitage were originally recovered at the site. Radial STPs excavated at 5 and 10 m (16.4 and 32.8 ft) intervals in cardinal directions around STP 11 did not recover additional cultural material or evidence of other potential cultural features (**Appendix A, Figure 6**). The existing pipeline trench was located in radial STP 11 N5, 5 m (16.4 ft) north of the potential feature.

The results of the investigation indicate the floodplain north of Apple Creek exhibited a high degree of variability within the soil profiles suggesting the lateral migration of Apple Creek across the valley floor, which combined with the disturbance from the existing pipeline, limits the potential for intact archaeological deposits to remain within the Survey Area. Despite this limited potential, one (1) possible cultural feature was identified in STP 11. Given the low density of artifacts and extent of negative shovel testing, the only portion of site 33WE0085 within the Survey Area that retains the potential to contain significant information is the possible feature identified in STP 11. ECT recommends the feature be avoided. If the potential feature cannot be avoided, ECT recommends the anomaly be revisited and be fully exposed and excavated to determine if the charcoal concentration is cultural in origin and to collect additional data (e.g., datable organic material or floral and faunal remains).

DEO has elected to avoid impacts to the potential feature. Temporary construction fencing will be installed and centered on STP 11. The avoidance buffer will extend 10 m (32.8 ft) to the east and west of STP 11 between the existing pipeline trench and the southern boundary of the LOD. No excavation will occur within this avoidance buffer. However, DEO may place timber matting on the ground surface

to allow for equipment to traverse the LOD (*Avoidance Plan, Appendix A, Figure 8*). As the potential feature was identified at the base of the plowzone, approximately 27 cm (10.6 in) below surface, the timber matting will adequately distribute the weight of machinery over the site and avoid impacts to the potential feature.

Given the limited amount of testing conducted within the mapped 32-acre boundary of site 33WE0085, the site cannot presently be evaluated for listing in the NRHP. However, with the avoidance plan implemented, ECT recommends the portions of site 33WE0085 remaining within the Project LOD do not contribute to the site's potential eligibility for listing in the NRHP.

## 6.0 Summary and Recommendations

DEO is proposing to replace a portion of the approximately 1,188.7 m (3,900 ft) of twelve (12)-inch natural gas steel pipeline under DEO's PIR program. The purpose of the program is to replace existing pipe to ensure the safety and reliability of pipeline operations. The PIR 2788 – Apple Creek project (Project) is located in Wooster Township, Wayne County. The Project is being permitted under USACE Nationwide Permit 12 and is subject to review by the Ohio Power Siting Board.

Initial background research for the Project identified one (1) previously recorded archaeological site within the LOD between Apple Creek and South Geyers Chapel Road. Site 33WE0085, the Taggart Farm Site, is a prehistoric site of unknown function that has not been evaluated for listing in the NRHP. Site records indicate the site was initially identified by the landowner in the 1960s but was not recorded until 1979. The site was recorded based on information provided by the landowner but was never field checked. The site boundary as depicted in the site records is approximated and extends across nearly 32 acres of residential and agricultural lands, of which approximately 2.27 acres intersect the LOD.

As the exact location and extent of site 33WE0085 is not presently known, DEO requested ECT conduct a Phase I archaeological survey of the approximately 2.27 acres of site 33WE0085 that intersect the Project (Survey Area). The purpose of the survey is to relocate any portions of site 33WE0085 that may remain intact within the Survey Area and to make recommendations as to the need for further work or avoidance of the site.

The Phase I archaeological survey was conducted in January and February 2024. A total of 45 STPs were excavated within the Survey Area. Shovel testing recovered four (4) prehistoric artifacts and one (1) potential cultural feature within the Survey Area in an area bisected by the existing pipeline. Given the nebulous nature of the original site boundary, it is not clear if the artifacts recovered represent the original location of site 33WE0085 or if the occupation identified during this investigation is one of many possible site locations situated within the approximately 32-acre area mapped as site 33WE0085.



Due to disturbances from the existing pipeline, the limited archaeological context inherent in the channel lag deposits underlying the Study Area resulting from the lateral migration of Apple Creek, the low density of artifacts, and the extent of negative shovel testing, it is ECT's conclusion that the only portion of site 33WE0085 within the Survey Area that retains the potential to contain significant information is the potential feature identified in STP 11. ECT recommends the feature be avoided. If the potential feature cannot be avoided, ECT recommends the potential feature be revisited, fully exposed, and excavated to determine if the charcoal concentration is cultural in origin and to collect any additional data (e.g., artifacts, datable organic material, or floral and faunal remains).

DEO has elected to avoid the potential feature. Temporary construction fencing will be installed encircling STP 11. The avoidance buffer will extend 10 m (32.8 ft) to the east and west of STP 11 between the existing pipeline trench and the southern boundary of the LOD. No excavation will occur within this avoidance buffer. However, DEO may place timber matting on the ground surface to allow for equipment to traverse the LOD (*Avoidance Plan, Appendix A, Figure 8*). As the potential feature was identified at the base of the plowzone, approximately 27 cm (10.6 in) below surface, the timber matting will adequately distribute the weight of machinery over the site and avoid impacts to the potential feature.

Given the limited amount of testing conducted within the mapped 32-acre boundary of site 33WE0085, the site cannot presently be evaluated for listing in the NRHP. However, with the avoidance plan implemented, ECT recommends the portions of site 33WE0085 remaining within the Project LOD do not contribute to the site's potential eligibility for listing in the NRHP.

## 7.0 References Cited

Abrams, Elliot M.

1992 Woodland Settlement Patterns in the Southern Hocking River Valley, Southeastern Ohio. In *Culture Variability in Context: Woodland Settlements of the Mid-Ohio Valley*, edited by Mark F. Seeman, pp. 19–23. Kent State University Press, Kent, Ohio.

Adovasio, J.M., R.C. Carlisle, K.A. Cushman, J. Donahue, J.E. Guilday, W.C. Johnson, K. Lord, P.W. Parmalee, R. Stuckenwrath, and P.W. Wirgman

1985 Paleoenvironmental Reconstruction at Meadowcroft Rockshelter, Washington County Pennsylvania. In *Environmental Extinction: Man in Late Glacial North America*, edited by Jim I. Mead and David J. Meltzer, pp. 73–110. Center for the Study of Early Man, University of Maine, Orono, Maine.

Bartlein, P.J., T. Webb III, and E. Fleri

1984 Holocene Climatic Change in the Northern Midwest: Pollen-Derived Estimates. *Quaternary Research* 22:361–374.

Belknap, Daniel, and John Kraft

1977 Holocene Relative Sea-Level Changes and Coastal Stratigraphic Units on the Northwest Flank of the Baltimore Canyon Trough Geosyncline. *Journal of Sedimentary Petrology* 47:610–629.

Blue, H.F.O.

1928 *History of Stark County, Ohio*. Vol. 1. S.J. Clarke, Chicago, Illinois.

Bond, Beverly W., Jr.

1941 The Foundations of Ohio. In *The History of the State of Ohio*, edited by C. Wittke, 1:pp. 1–507. Ohio State Archaeological and Historical Society, Columbus, Ohio.

Bradstreet, T.E., and R.B. Davis

1975 Mid-Postglacial Environments with Emphasis on Maine. *Arctic Anthropology* 12(2):7–22.

Brockman, S

1998 *Physiographic Regions of Ohio*. ODNR - Division of Geological Survey.

Brown, Jeffery D.

1981 *The Tower Site and Ohio Monongahela*. Research Papers in Archaeology No. 3. Kent State University, Kent, Ohio.

Bush, David R.

1978 *An Assessment of the Cultural Resources for the Proposed Easterly Separated Sewer Area Project, Cuyahoga and Lake Counties, Ohio*. Cleveland Museum of Natural History, Cleveland, Ohio.

Carbone, Victor A.

1974 Environment and Prehistory in the Shenandoah Valley. Unpublished PhD, Catholic University of America, Washington D.C.

Carskadden, Jeff, and Jim Morton

1977 *The Richards Site and the Philo Phase of the Fort Ancient Tradition. Occasional Papers in Muskingum Valley Archaeology 1-9.* Muskingum Valley Archaeological Survey, Zanesville, Ohio.

Chapman, Jefferson

1985 Archaeology and the Archaic Period in the Southern Ridge and Valley Province. In *Structure and Process in Southeastern Archaeology*, edited by Roy S. Dickens and H. Trawick Ward. Alabama.

Clagget, Stephen R., and John S. Cable

1982 *The Haw River Sites: Archaeological Investigations at Two Stratified Sites in the North Carolina Piedmont.* Commonwealth Associates, Inc, Wilmington, North Carolina.

Coe, Joffre

1964 The Formative Cultures of the Carolina Piedmont. In , 54(5):

Dancey, William S.

1992 A Community Model of Ohio Hopewell Settlement. In *Cultural Variability in Context: Woodland Settlements of the Mid-Ohio Valley*, edited by Mark F. Seeman. Kent State University Press, Kent, Ohio.

Dancey, William S., and Paul J. Pacheco

1997 A Community Model of Ohio Hopewell Settlement. In *Ohio Hopewell Community Organization*, edited by William S. Dancey and Paul J. Pacheco. Kent State University Press, Kent, Ohio.

Davis, M.B, R.W. Spear, and L.C.K. Shane

1980 Holocene Climate of New England. *Quaternary Research* 14:240–250.

Delcourt, Hazel R.

1979 Late Quaternary Vegetation History of the Eastern Highland Rim and Adjacent Cumberland Plateau of Tennessee. *Ecological Monographs*:255–280.

Delcourt, Paul A., and Hazel R. Delcourt

1986 Late Quaternary Vegetational Change in the Central Atlantic States. In *The Quaternary of Virginia - A Symposium Volume*, edited by J.N. McDonald and S.O. Bird, pp. 23–35. Commonwealth of Virginia, Charlottesville, Virginia.

DeRegnaucourt, R.

1983 *Middle Archaic (Data Free Zone) Study Unit for All of Ohio. Report to the Ohio Historic Preservation Office, Columbus.*

1986 *Preservation Plan for Late Archaic Study Unit in Northwestern Ohio.* Ohio Historic Preservation Office, Columbus, Ohio.

Eisenberg, Leonard

1978 *Paleo-Indian Settlement Pattern in the Hudson and Delaware River Drainages.* Occasional publications in northeastern anthropology 4. Department of Anthropology, Franklin Pierce College, Rindge, New Hampshire.

Essenpreis, Patricia S.

1978 Fort Ancient Settlement: Differential Response at a Mississippian - Late Woodland Interface. In *Mississippian Settlement Patterns*, edited by B.D. Smith, pp. 143–167. Academic Press, New York.

Fitting, James E.

1978 Regional Cultural Development, 300 B.C. to A.D. 1000. In *Handbook of North American Indians: Northeast, Volume 15*, edited by Bruce Trigger. Smithsonian Institution Press, Washington D.C.

Gardner, William M.

1974 *The Flint Run Paleo Indian Complex: Report on the 1971-1973 Seasons*. 1974 The Flint Run Paleo Indian Complex: Report on the 1971-1973 Seasons. Occasional Publication 1, Department of Anthropology. Catholic University of America, Washington D.C.

Goodyear, A. C.

1979 Hypothesis for the Use of Cryptocrystalline Raw Materials Among Paleo-Indian Groups of North America. *Institute of Archaeology and Anthropology, Columbia* 156. Research Monograph Series.

Graetzer, M.A.

1986 Settlement Patterns and Paleoclimatic Modeling: A Preliminary Study of Data from the Bald Eagle Watershed of Central Pennsylvania. Unpublished Master's Thesis, Pennsylvania State University, University Park.

Greber, N.

1983 *Early-Middle Woodland Study Unit Archeological Resource Plan, Northeast Ohio*. Ohio Historic Preservation Office, Columbus, Ohio.

Griffin, James B.

1943 *The Fort Ancient Aspects: Its Cultural and Chronological Position in Mississippi Valley Archaeology*. University of Michigan Press, Ann Arbor, Michigan.

1967 Eastern North American Archaeology: A Summary. *Science* 156(3772):175–191.

Guilday, J.E., P.W. Parmalee, and H.W. Hamilton

1977 The Clark's Cave Bone Deposit and the Late Pleistocene of the Central Appalachian Mountains of Virginia. *Bulletin of Carnegie Museum of Natural History* No. 2:1–87.

Hansen, Michael C.

1995 The Ice Age in Ohio. Modified from Education Leaflet No. 7 Revised Edition. Ohio Division of Natural Resources.

Heald, Edward Thorton

1949 The Stark County Story as Broadcast over WHBC-FM. Stark County Historical Society.

1958 *The Suburban Era 1917-1958 Volume IV Part 2; Being Scripts 302-370 as broadcast over WHBC-WHBC-FM. Rearranged and edited as a County History with Bibliography and index*. Stark County Historical Society, Canton, Ohio.

Herbstritt, J.T.



1983 *Excavation of Two Monongahela Sites: Late Woodland Gensler (36GR63) and Historic Throckmorton (36GR160)*. NPW Consultants, Inc, Pittsburgh, Pennsylvania.

Howe, H.

1902 *Historical Collections of Ohio, 2 vols.* H. Howe, Cincinnati, Ohio.

Hunker, H.L.

1958 *Industrial Evolution of Columbus, Ohio. Bureau of Business Research Monograph Number 93.* Ohio State University, Columbus, Ohio.

Jackson, Kenneth E., and E. Jean Harris

1992 *Phase I and II Cultural Resources Investigations of Columbia Gas Transmission Corporation's 1.1-Mile Line L Pipeline Replacement Project in Medina County, Ohio.* Gray & Pape, Inc., Cincinnati, Ohio.

Jefferies, Richard W.

2008 *Holocene Hunter-Gatherers of the Lower Ohio River Valley.* University of Alabama Press, Tuscaloosa, Alabama.

Jones, R.L.

1983 *History of Agriculture in Ohio to 1880.* Kent State University Press, Kent, Ohio.

Kimball, Larry R.

1996 Early Archaic Settlement and Technology: Lessons from Tellico. In *The Paleoindian and Early Archaic Southeast*, edited by David G. Anderson and Sassaman, Kenneth E. University of Alabama Press, Tuscaloosa, Alabama.

Kime, J.

1986 *Preservation Plan for Early Woodland Study Unit Drainage A, Western Lake Erie Spatial Unit. Report to the Ohio Historic Preservation Office, Columbus.*

King, J.E.

1980 Post-Pleistocene Vegetational Changes in the Midwestern United States. In *Archaic Prehistory of the Prairie-Plains Border*, edited by A.E. Johnson, pp. 3–11. University of Kansas Publications in Anthropology No. 12, Lawrence, Kansas.

Kovar, A.J.

1965 Pollen Analysis of the Bear Meadows Bog of Central Pennsylvania. *Pennsylvania Academy of Science* 38:16–24.

Lovejoy, Claude O.

1967 Caldwell's Little Bluff: An Unusual Adena Burial Site. In *Studies in Ohio Archeology*, edited by Olaf H. Prufer. Press of Western Reserve University, Cleveland, Ohio.

MacDonald, George F.

1968 *Debert: A Paleo-Indian Site in Central Nova Scotia.* Anthropology Papers. National Museum of Canada, Ottawa.

Maslowski, Robert F., and Mark F. Seeman

1992 Woodland Archeology in the Mid-Ohio Valley: Setting Parameters for Ohio Main Stem/ Tributary Comparisons. In *Cultural Variability in Context: Woodland Settlements of the Mid-Ohio Valley*, edited by Mark F. Seeman. Kent State University Press, Kent, Ohio.

Mason, R. J.

1981 *Great Lakes Archaeology*. Academic Press, New York, New York.

Mayer-Oakes, William J.

1955 *Prehistory of the Upper Ohio Valley: An Introductory Archeological Study*. Annals of the Carnegie Museum, Volume 34, Pittsburgh, Pennsylvania.

Milliman, J., and K. Emery

1968 Sea Levels during the Past 35,000 Years. *Science* 162:1121–1123.

Mills, William C.

1914 *Archeological Atlas of Ohio : showing the distribution of the various classes of prehistoric remains in the state, with a map of the principal Indian trails and towns*. Ohio State Archaeological and Historical Society, Columbus, Ohio.

Muller, Jon

1986 *Archaeology of the Lower Ohio River Valley*. Academic Press, New York.

Noble, Allen G., and Hubert G.H. Wilhelm

1995 *Barns of the Midwest*. Ohio University Press, Athens, Ohio.

Noss, Reed

2023 Southern Great Lakes Forests. One Earth.

OHPO

2022 Archaeology Guidelines. Ohio Historic Preservation Office.

Payne, J.H.

1987 Windy City (154-16): A Paleoindian Lithic Workshop in Northern Maine. Unpublished Master's Thesis, University of Maine, Orono, Maine.

Penny, David W.

1985 The Late Archaic Period. In *Ancient Art of the American Woodland Indians*, edited by David S. Brose, James A. Brown, and David W. Penny, pp. 15–41. Harry N. Abrams, Inc, New York.

Perrin, W.H.

1881 *History of Stark County*. Baskin and Battey, Chicago, Illinois.

Pollack, David, and A. Gwynn Henderson

1983 Contact Period Developments in the Middle Ohio Valley. In . Pittsburgh, Pennsylvania.

Pratt, Michael G.

1981 The Western Basin Tradition: Changing Settlement-Subsistence Adaptation in the Western Lake Erie Basin Region. Unpublished PhD, Case Western Reserve University, Cleveland, Ohio.

Prufer, Olaf H.

1967 The Scioto Valley Archaeological Survey. In *Studies in Ohio Archaeology*, edited by Olaf H. Prufer and Douglas H. MacKenzie. Western Reserve University Press, Cleveland, Ohio.

Prufer, Olaf H., and Douglas H. McKenzie

1966 Peters Cave: Two Woodland Occupations in Ross County, Ohio. *Journal of Science* 66:233–253.

Sassaman, Kenneth E., Mark J. Brooks, Glen T. Hanson, and David T. Anderson

1990 *Native American Prehistory in the Middle Savannah River Valley: Synthesis of Archaeological Investigations on the Savannah River Site, Aiken and Barnwell Counties, South Carolina*. Savannah River Archaeological Research Papers 1. South Carolina Institute of Archaeology and Anthropology, Columbia, South Carolina.

Seeman, Mark F.

1992 The Bow and Arrow, the Intrusive Mound Complex, and Late Woodland Jack's Reef Horizon in the Mid-Ohio Valley. In *Cultural Variability in Context: Woodland Settlements of the Mid-Ohio Valley*, edited by Mark F. Seeman, pp. 41–51. Kent State University Press, Kent, Ohio.

Skinner, Shaune M., and David S. Brose

1985 *RP3 Study Unit, Late Prehistoric and Protohistoric Periods in Northeast Ohio, Study Unit F*. Ohio Historical Society, Columbus, Ohio.

Slucher, E.R., G.E. Swinford, G.E. Larson, and Others

2006 Bedrock geologic map of Ohio: Ohio Division of Geological Survey Map BG-1.

Stothers, David M., and Timothy J. Abel

1993 Archaeological Reflections of the Late Archaic and Early Woodland Time Periods in the Western Lake Erie Region. *Archaeology of Eastern North America* 21:25–109.

Stothers, David M., Timothy J. Abel, and Andrew M. Schneider

2001 Archaeological Perspectives in the Western Lake Erie Basin. In *Archaic Traditions in Ohio & Kentucky Prehistory*, edited by Olaf H. Prufer, Sarah E. Pedde, and Richard S. Meindl. Kent State University Press, Kent, Ohio.

Tankersley, Kenneth B.

1996 Ice Age Hunters and Gatherers. In *Kentucky Archaeology*, edited by R. Barry Lewis, pp. 39–78. The University Press of Kentucky, Lexington, Kentucky.

2008 Three Saylor's: An Appalachian Mountain Clovis Site in Southeastern Kentucky. *Current Research in the Pleistocene* 25:110–112.

Tankersley, Kenneth B., Michael R. Waters, and Thomas Weir Stafford

2009 Clovis and the American Mastodon at Big Bone Lick, Kentucky. *American Antiquity* 74:1–10.

Thomas, D.H.

1978 Arrowheads and Atlatl Darts: How the Stones Got the Shaft. *American Antiquity* 43:461–472.

USDA-NRCS

2024 Web Soil Survey - Web Application.

<https://websoilsurvey.sc.egov.usda.gov/App/HomePage.htm>.

Waters, Michael R., Thomas W. Jr. Stafford, Brian G. Redmond, and Kenneth B. Tankersley

2009 The Age of the Paleoindian Assemblage at Sheriden Cave, Ohio. *American Antiquity* 74:107–111.

Watts, W.A.

1979 Late Quaternary Vegetation of Central Appalachia and the New Jersey Coastal Plain.

*Ecological Monographs* 49:427–469.

1983 Vegetational History of the Eastern United States 25,000 to 10,000 years ago. In *Late Quaternary Environments of the United States Volume I: The Late Pleistocene.*, edited by Stephen C. Porter, pp. 294–310. University of Minnesota Press, Minneapolis, Minnesota.

Wilhelm, Hubert G.H.

1982 *The Origin and Distribution of Settlement Groups: Ohio: 1850*. Self-Published, Athens, Ohio.

Willey, Gordon R., and Phillip Phillips



1958 *Method and Theory in American Archaeology*. University of Chicago Press, Chicago, Illinois.

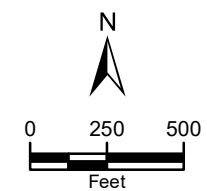


## Appendix A Background Figures





-  Limit of Disturbance
-  Potential Access Road



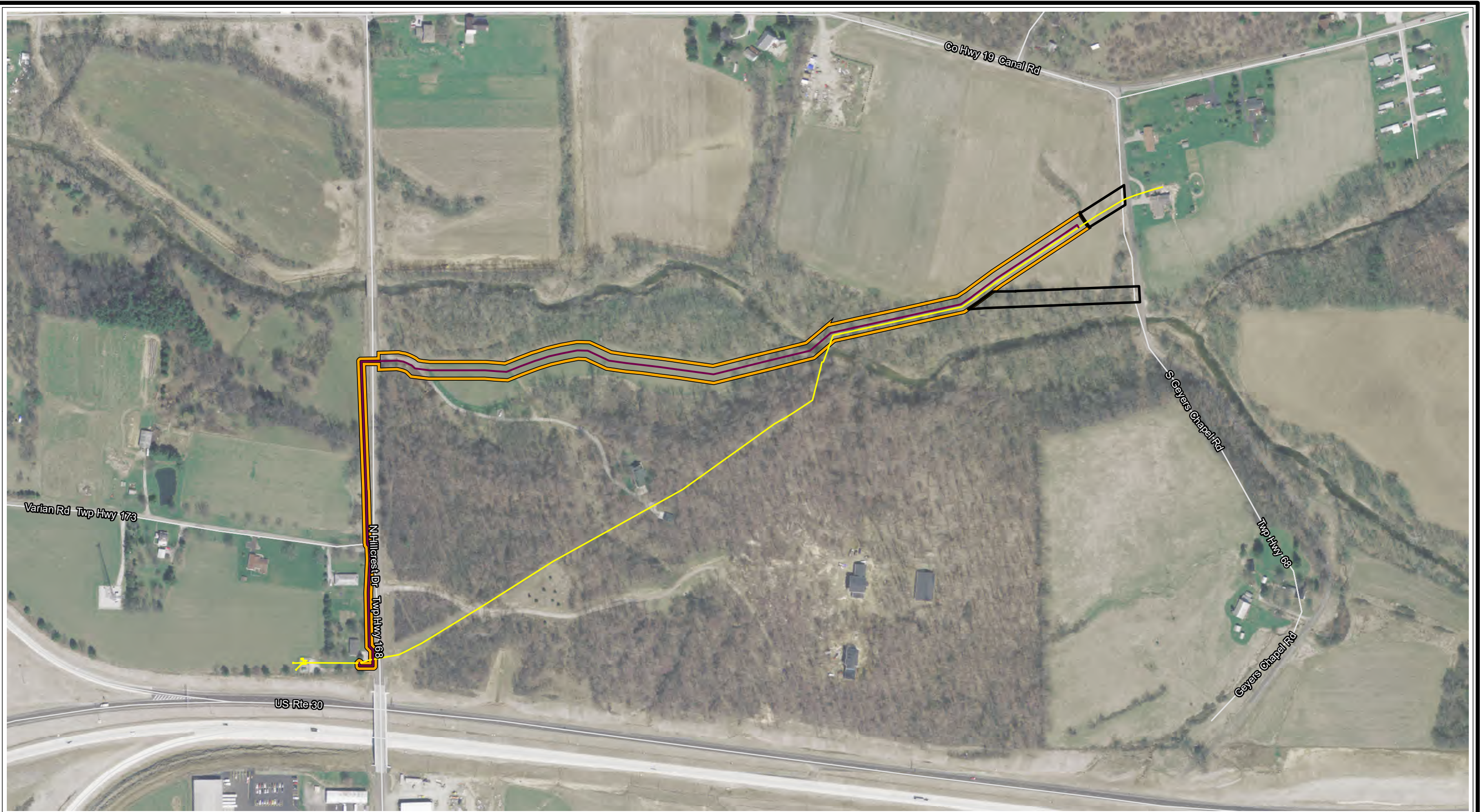
Base Layer: USGS 7 minute Quadrangel Wooster, OH 1998

**Figure 1**  
**USGS Topographic Map**

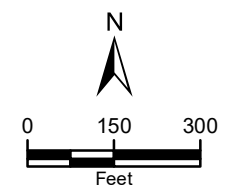
PIR 2788 - Apple Creek  
Dominion Energy Ohio  
Wayne County, Ohio  
Date: 2/14/2024







- Limit of Disturbance
- Potential Access Road
- Proposed Pipeline
- Existing Pipeline



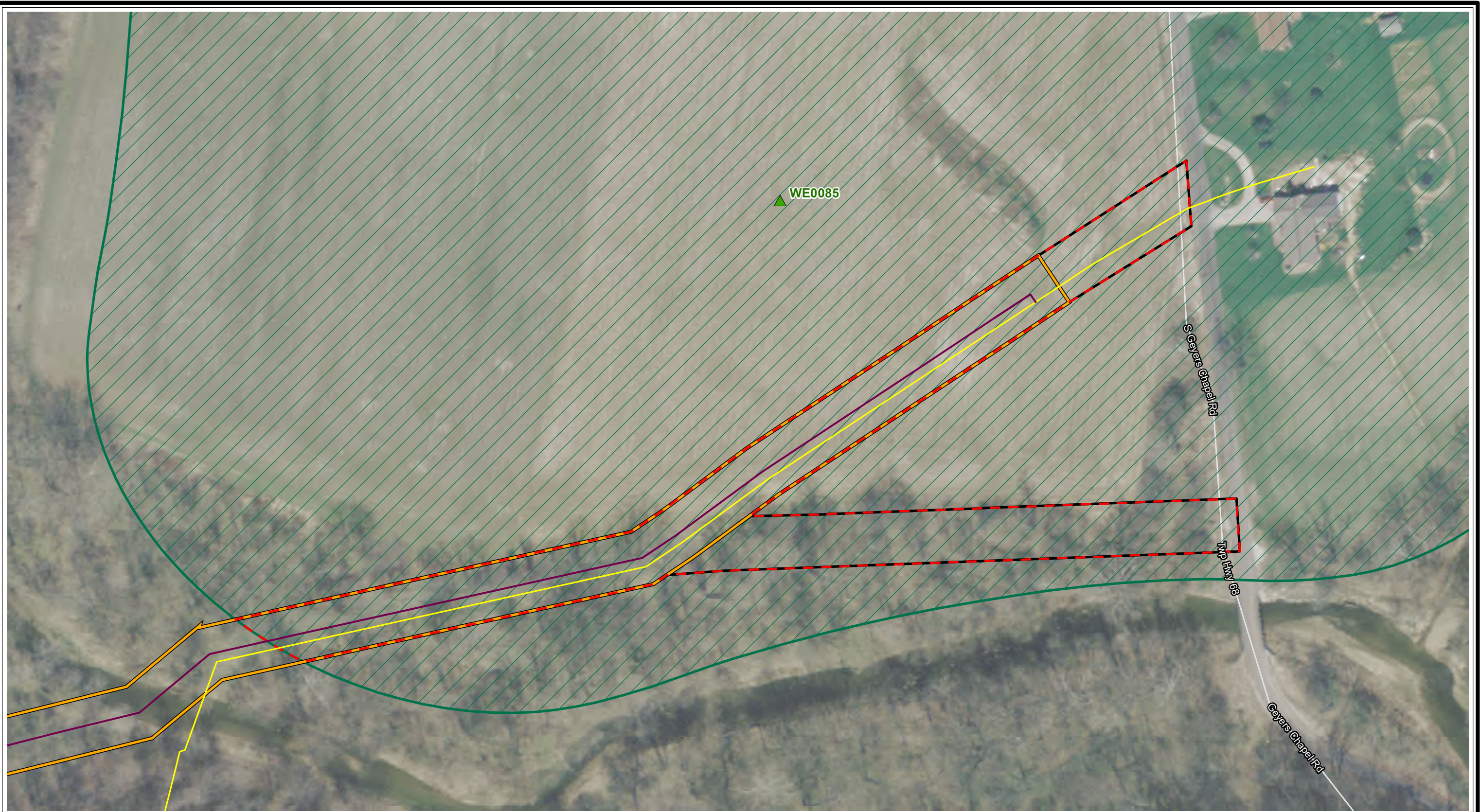
Base Layer: OSIP Aerial, 2016

**Figure 2**  
**Project Location Map**

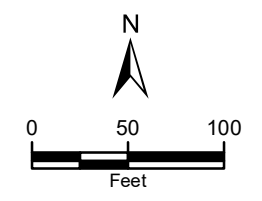
PIR 2788 - Apple Creek  
Dominion Energy Ohio  
Wayne County, Ohio  
Date: 2/14/2024







- Survey Area ( $\pm$  2.27 ac.)
- OAI Boundary
- Limit of Disturbance
- ▲ OAI Site
- Potential Access Road
- Proposed Pipeline
- Existing Pipeline



Base Layer: OSIP Aerial, 2016

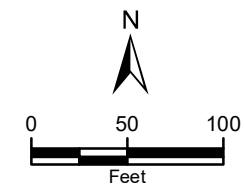
**Figure 3**  
**Survey Area Map**  
 PIR 2788 - Apple Creek  
 Dominion Energy Ohio  
 Wayne County, Ohio  
 Date: 2/14/2024







- Survey Area ( $\pm$  2.27 ac.)
- Limit of Disturbance
- Potential Access Road
- NRCS Soils
- NRCS Soils - Drainage Class
- Well drained
- Moderately well drained



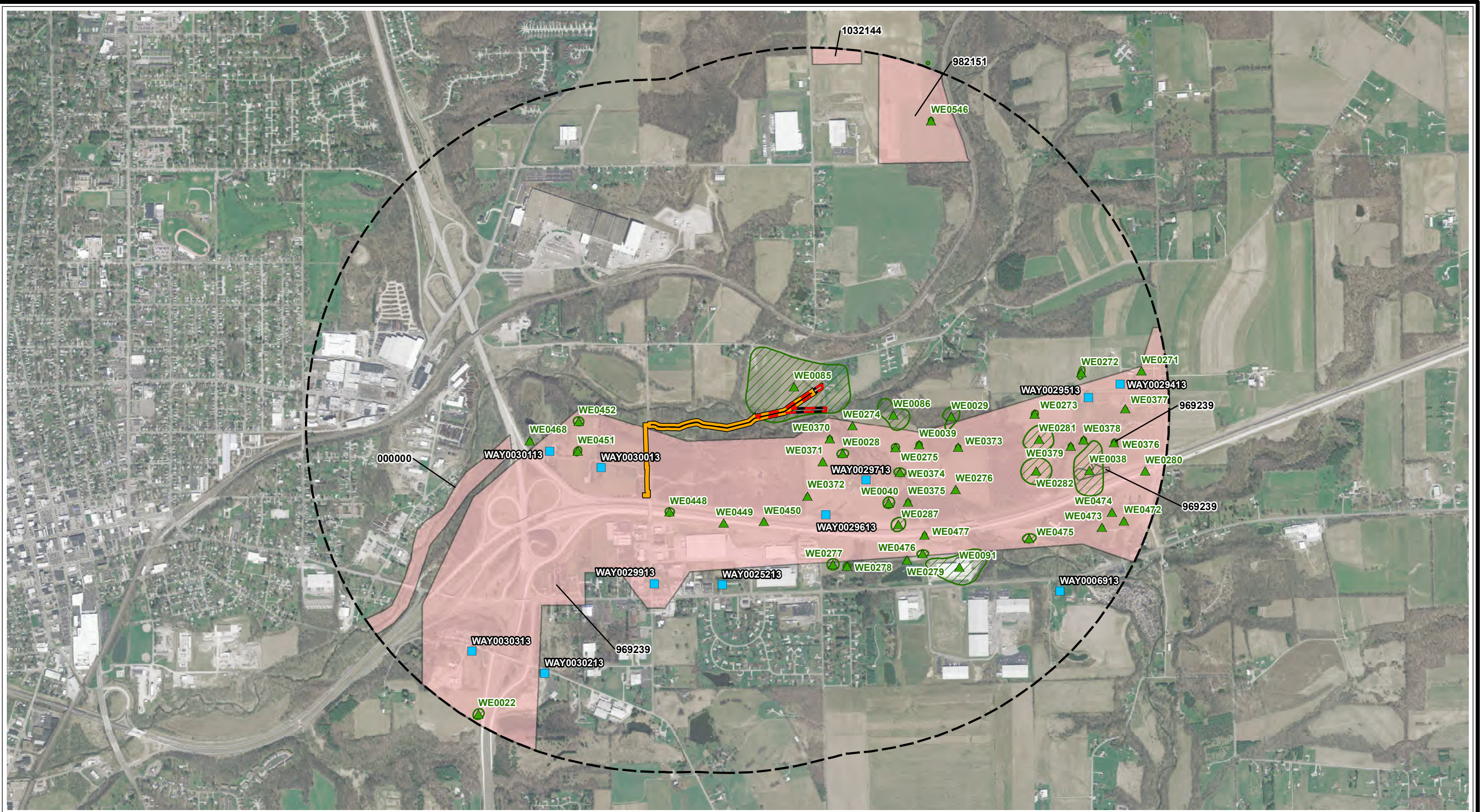
Base Layer: OSIP Aerial, 2016

**Figure 4**  
**NRCS Soils Mapped in Survey Area**

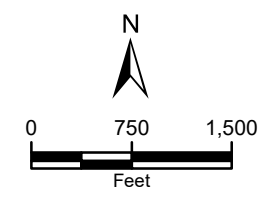
PIR 2788 - Apple Creek  
 Dominion Energy Ohio  
 Wayne County, Ohio  
 Date: 2/14/2024







- Survey Area (± 2.27 ac.)
- Limit of Disturbance
- Potential Access Road
- 1-Mile Buffer
- Archaeological Survey Area
- OAI Boundary
- ▲ OAI Site
- Historic Structure



Base Layer: OSIP Aerial, 2016

**Figure 5**  
**Previously Recorded Cultural Resources**

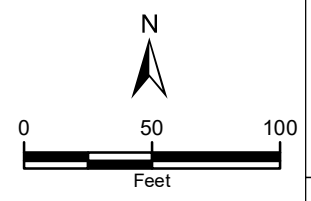
PIR 2788 - Apple Creek  
 Dominion Energy Ohio  
 Wayne County, Ohio  
 Date: 2/14/2024







- Survey Area ( $\pm$  2.27 ac.)
- Limit of Disturbance
- Potential Access Road
- Existing Pipeline
- Proposed Pipeline
- OAI Boundary
- ▲ OAI Site
- ◇ Shovel Test Pits
- ◇ Negative
- ◇ Precontact



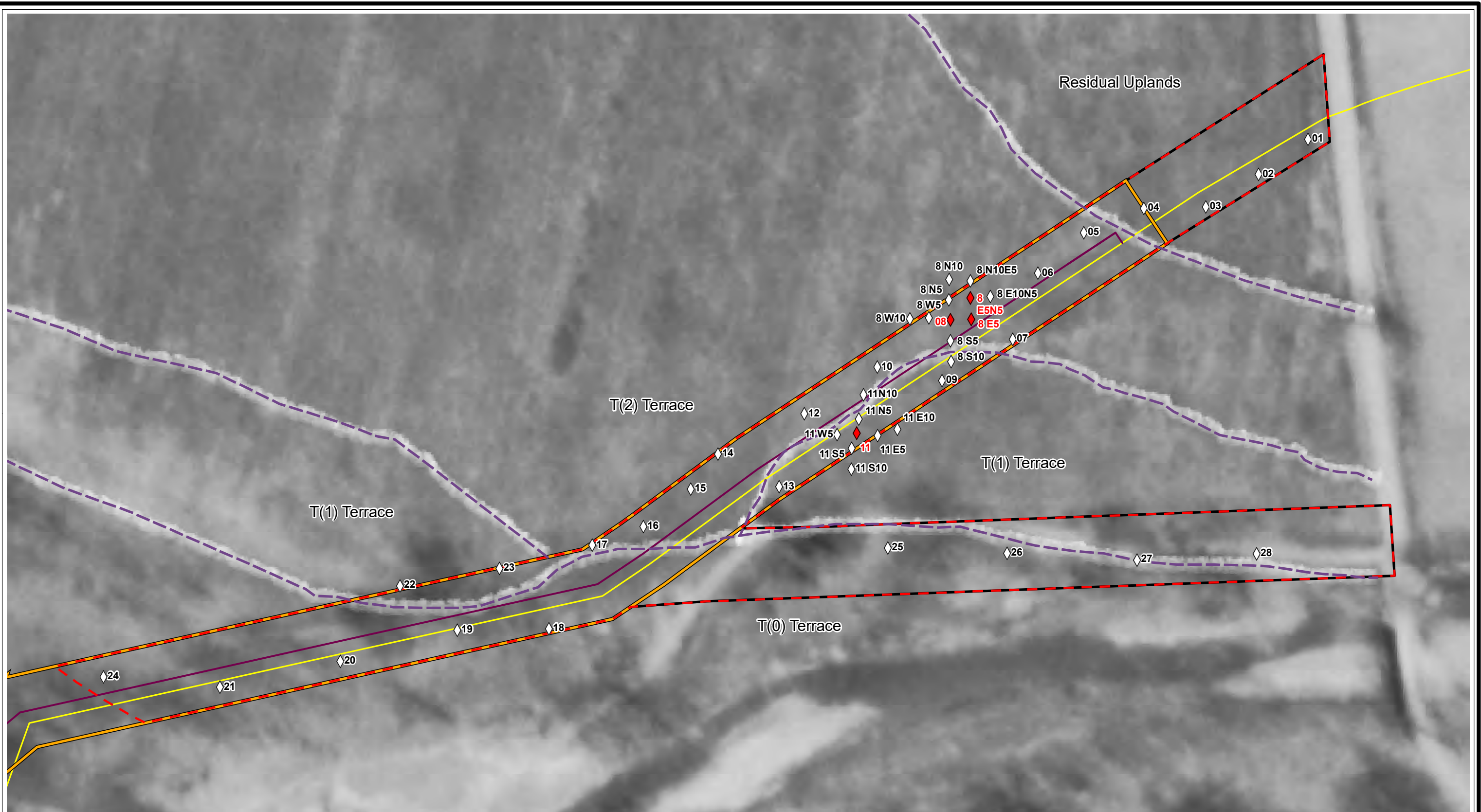
Base Layer: OSIP Aerial, 2016

**Figure 6**  
**Results of Phase I Archaeological Survey**

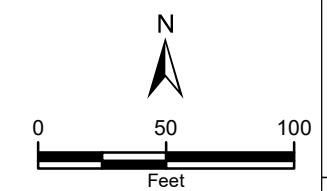
PIR 2788 - Apple Creek  
 Dominion Energy Ohio  
 Wayne County, Ohio  
 Date: 2/14/2024







- Survey Area ( $\pm$  2.27 ac.)
  - Limit of Disturbance
  - Potential Access Road
  - Existing Pipeline
  - Proposed Pipeline
  - Terrace Break Line
- Shovel Test Pits
- Negative
  - Precontact

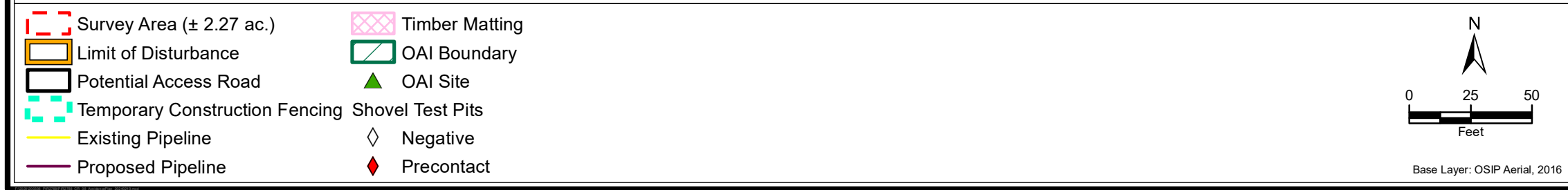
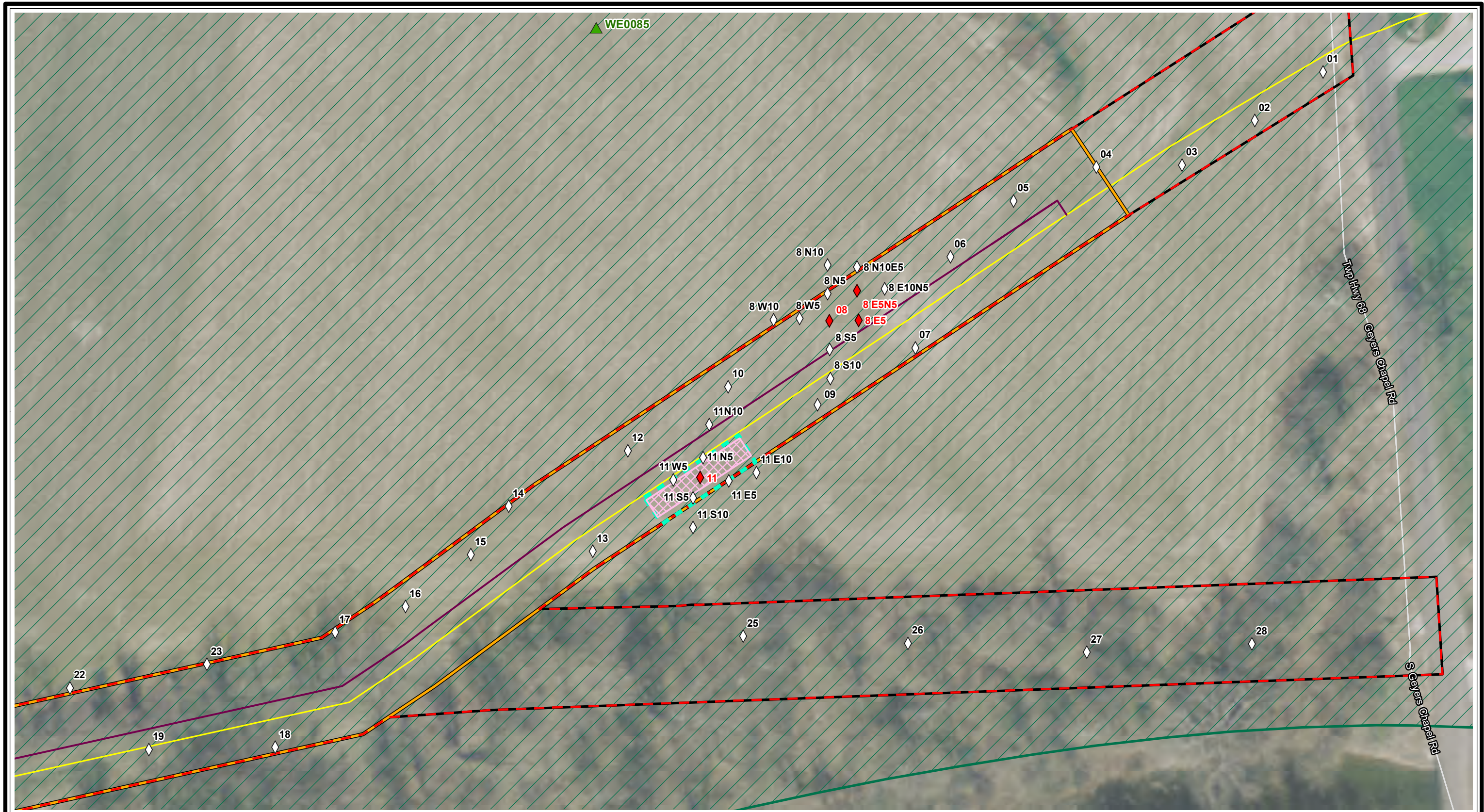


Base Layer: OSIP Aerial, 2016

**Figure 7**  
**Alluvial Terraces on 1960 Aerial Photograph**  
 PIR 2788 - Apple Creek  
 Dominion Energy Ohio  
 Wayne County, Ohio  
 Date: 2/14/2024







**Figure 8**  
**Avoidance Plan**  
 PIR 2788 - Apple Creek  
 Dominion Energy Ohio  
 Wayne County, Ohio  
 Date: 2/19/2024

## Appendix B Photographs





***Photo 1: Overview of Survey Area Facing Southwest***



***Photo 2: Overview of Survey Area Facing Northeast***





***Photo 3: Facing Southeast Showing Bounding Ridge South of Apple Creek, Outside Survey Area***





***Photo 4: Facing North, Showing Edge of T(0) Terrace within Survey Area***





***Photo 5: Facing North, Showing Survey Area and Terrace Risers Across Apple Creek Floodplain***





*Photo 6: Artifacts Recovered from STP 8 and Surrounding Radials*



***Photo 7: Potential Cultural Feature Identified in STP 11***





*Photo 8: Core Fragment/Possible Scraper Recovered from STP 11*



## Appendix C Representative Soil Profiles

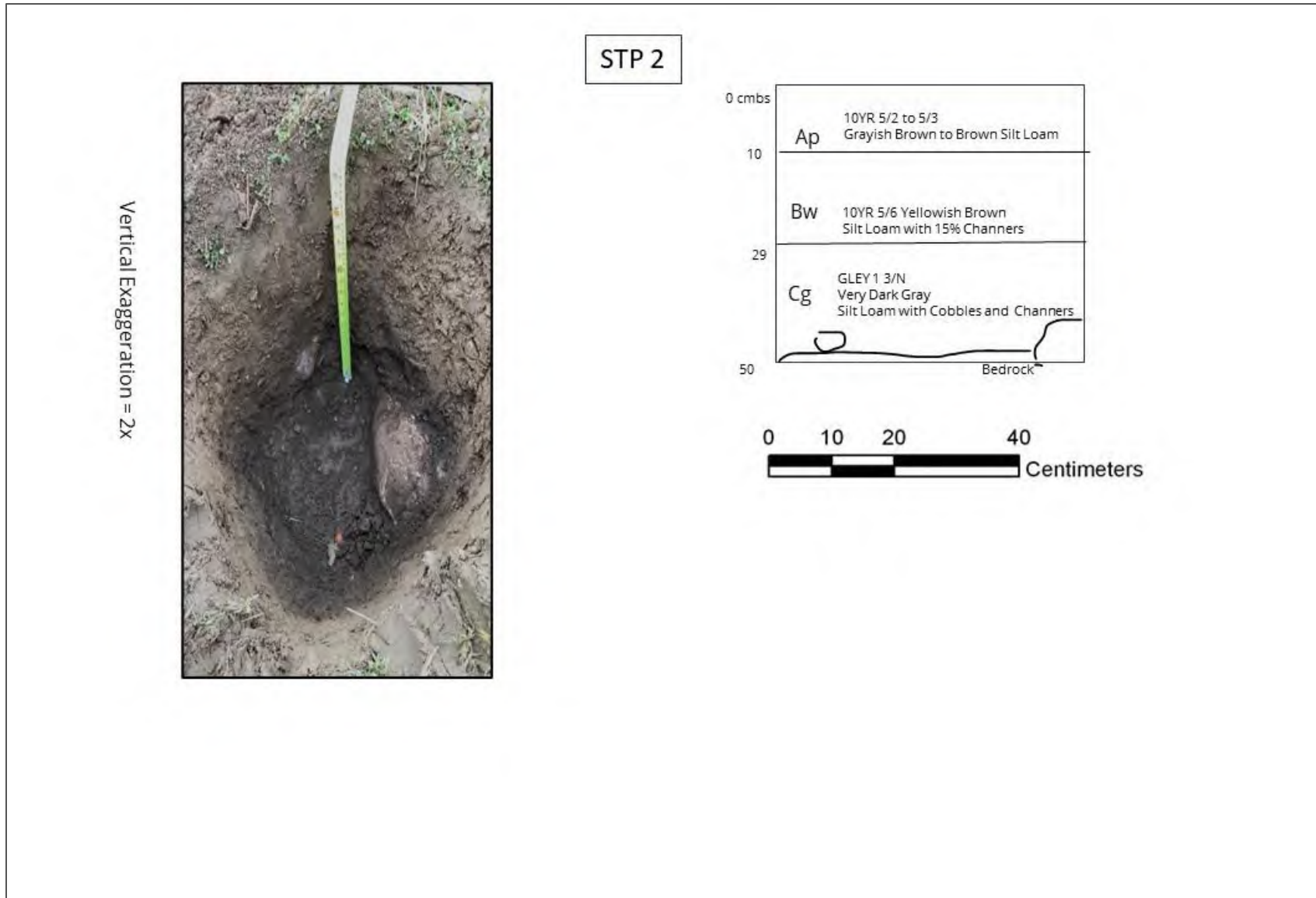
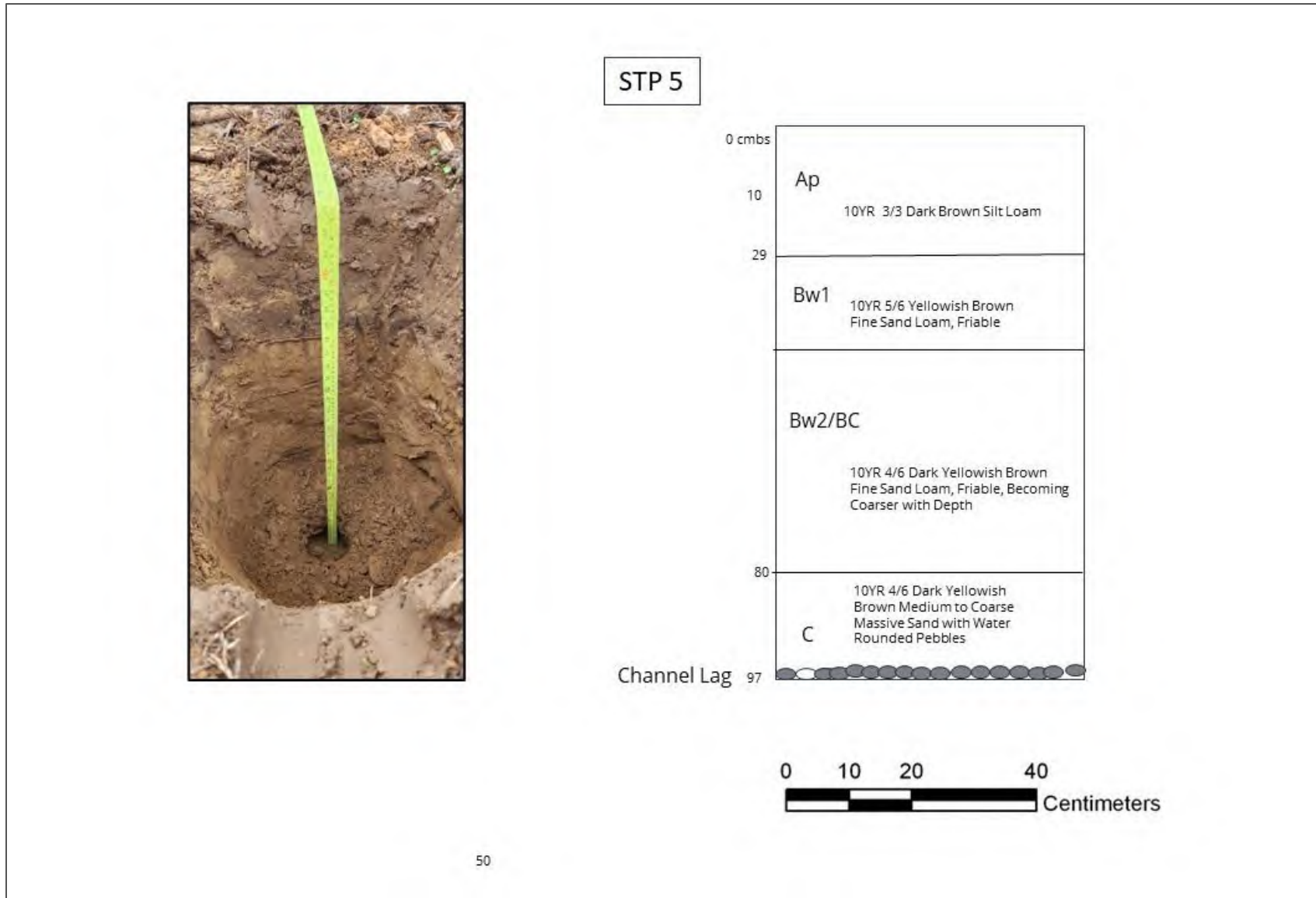


Figure 1: Representative Soil Profile from STP 2



**Figure 2: Representative Soil Profile from STP 5**





**Figure 3: Representative Soil Profile from STP 8**



**Figure 4: Representative Soil Profile from STP 8 E5**

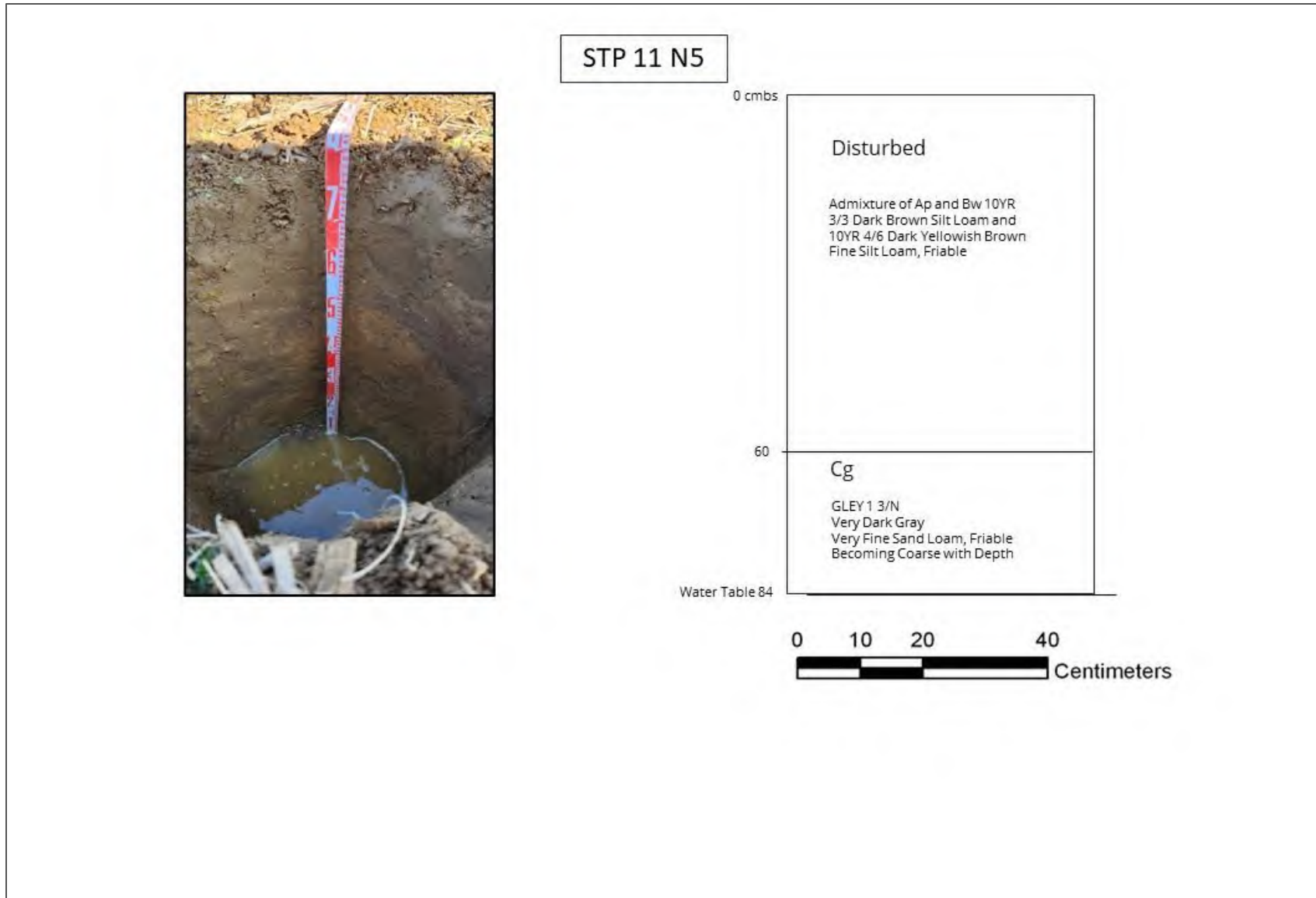


Figure 5: Representative Soil Profile from STP 8 E5N5





Figure 6: Representative Soil Profile from STP 11 E5



**Figure 7: Representative Soil Profile from STP 11 N5**

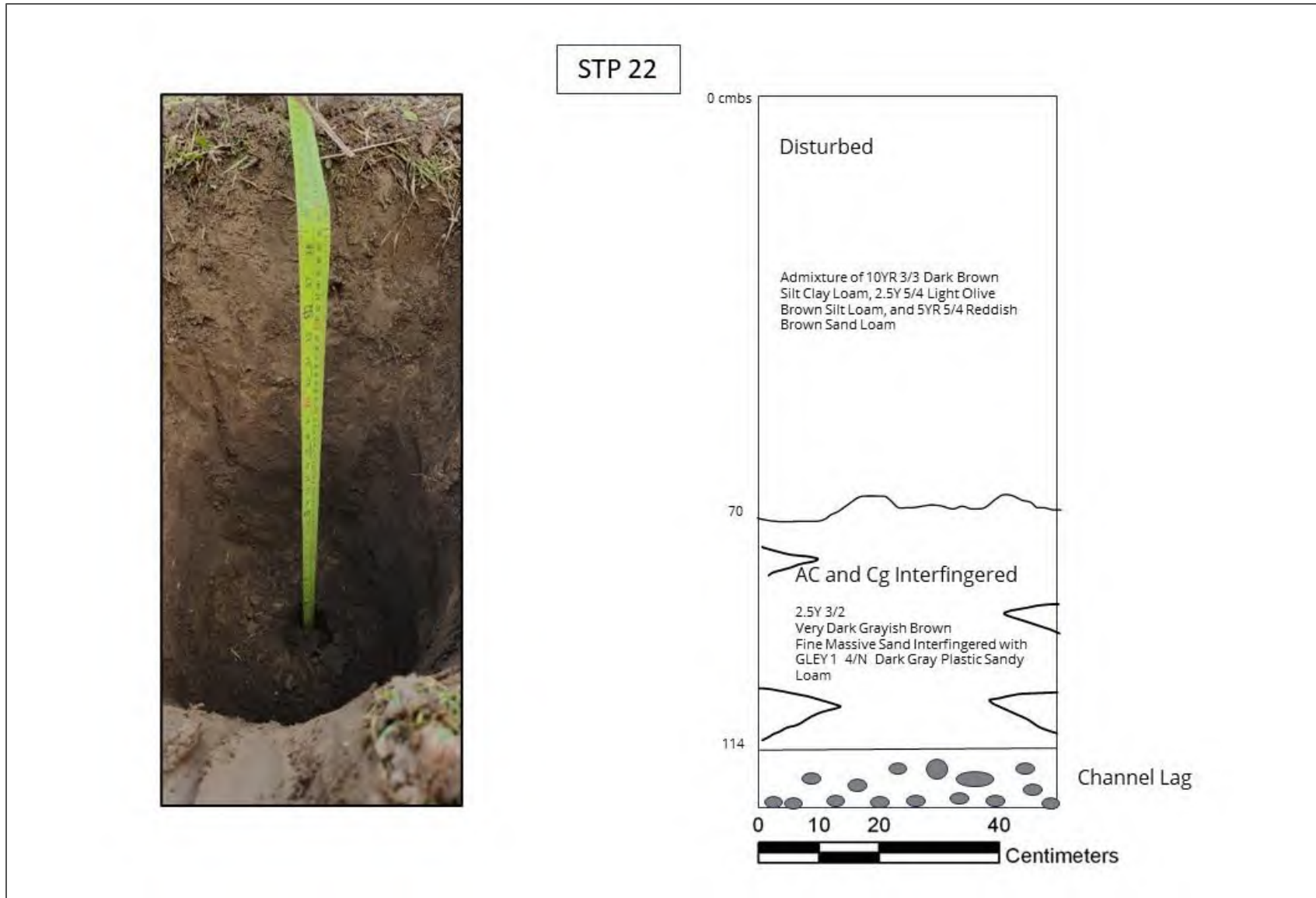
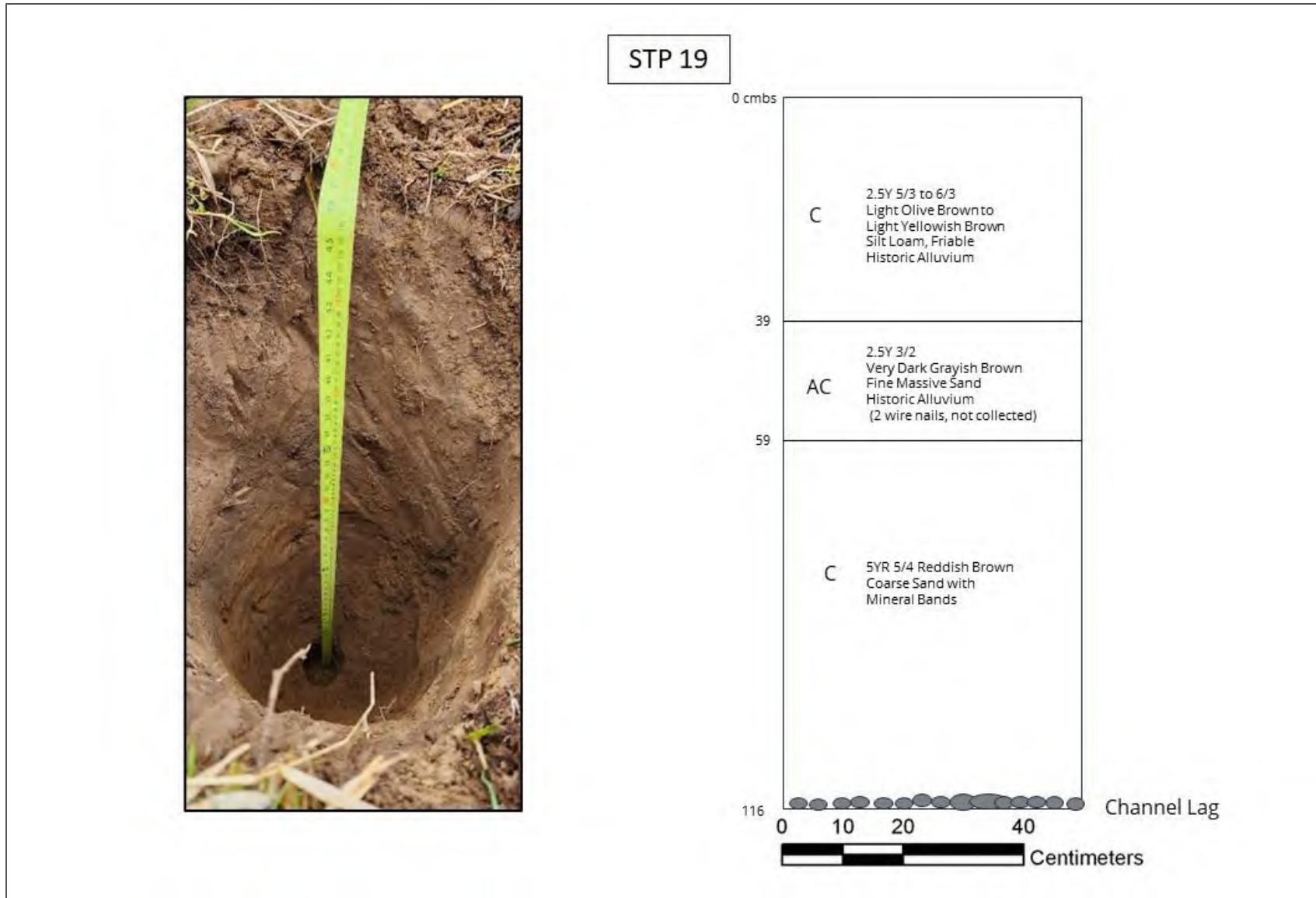


Figure 8: Representative Soil Profile from STP 22





**Figure 9: Representative Soil Profile from STP 19**

## Appendix D Artifact Inventory

Site	Field Specimen	Excavation Unit	UTM 17N (NAD 1983)		Stratum	Top Depth (cm)	Bottom Depth (cm)	Artifact Type	Material Type	Quantity
			Easting	Northing						
33WE0085	1	STP 8	424344	4517389	Ap	0	28	Flake Fragment	Black Chert	1
33WE0085	2	STP 8 E5	424349	4517389	Ap	0	38	Tertiary Flake	Light Gray Chert	1
33WE0085	3	STP 8E5N5	4243438	4517395	Ap	0	39	Flake Fragment	Gray Chert	1
33WE0085	4	STP 11	424320	4517362	Ap/Bw	0	27	Core Fragment/Scraper	Gray Chert	1



**ATTACHMENT F**  
**STORMWATER POLLUTION PREVENTION PLAN**



**OHIO GENERAL PERMIT AUTHORIZATION FOR STORMWATER  
DISCHARGES ASSOCIATED WITH CONSTRUCTION ACTIVITY UNDER  
THE NATIONAL POLLUTANT DISCHARGE ELIMINATION SYSTEM (NPDES)**

**The East Ohio Gas Company, d/b/a Dominion Energy Ohio  
Stormwater Pollution Prevention Plan (SWP3)**

**PIR 2788 – Apple Creek  
Wooster Township, Wayne County, Ohio**

**Planned Construction Start Date: June 2024**

**Planned Construction Completion Date: December 2024**

**Construction Supervisor: \_\_\_\_\_**

**Telephone: \_\_\_\_\_**

**Project Manager (signature): \_\_\_\_\_**

**Construction Contractor (signature): \_\_\_\_\_**

**Environmental Inspector (signature): \_\_\_\_\_**

**Note:**

**THIS PLAN MUST BE KEPT AT THE  
CONSTRUCTION SITE DURING WORKING HOURS**

**SWP3 Prepared: February 22, 2024  
Prepared by: Environmental Consulting & Technology, Inc.**


DULY AUTHORIZED

**OPERATOR/PERMITEE CERTIFICATION**

I certify that the positions named below are my duly authorized representatives for the Ohio EPA General Construction Stormwater Permits (Ohio NPDES General Permit OHC000006 or General Permit for Storm Water Discharges Associated with Construction Activity from Oil and Gas Linear Transmission Line and Gathering Line Installation OHCG00001) for Discharges of Stormwater from Construction Activities. I certify that these positions named below and defined within the corresponding SWPPP are my duly authorized representatives to have overall responsibilities sufficient to implement the SWPPP, amend or modify the SWPPP, and sign all required reports as assigned.

I also certify that the positions named below are my duly authorized representatives for the Ohio EPA General Permit Authorization to Discharge Hydrostatic Test Water (Ohio NPDES General Permit OHH000004). These individuals are my duly authorized representatives to sign all required reports or other information that may be requested by the Ohio EPA Director.

“Facilities Project Manager, Owner  
Project Engineer  
Environmental Compliance Coordinator  
Supervisor Environmental  
Qualified Inspection Personnel”

Signature   
Printed Name Zachary R. Goodson  
Title Director - Gas operations  
Date 5-4-2023

This Operator Certification must be signed by a responsible corporate officer or delegated authority.



DULY AUTHORIZED

**OPERATOR/PERMITEE CERTIFICATION**

I certify that the positions named below are my duly authorized representatives for the Ohio EPA General Construction Stormwater Permits (Ohio NPDES General Permit OHC000006 or General Permit for Storm Water Discharges Associated with Construction Activity from Oil and Gas Linear Transmission Line and Gathering Line Installation OHCG00001) for Discharges of Stormwater from Construction Activities. I certify that these positions named below and defined within the corresponding SWPPP are my duly authorized representatives to have overall responsibilities sufficient to implement the SWPPP, amend or modify the SWPPP, and sign all required reports as assigned.

I also certify that the positions named below are my duly authorized representatives for the Ohio EPA General Permit Authorization to Discharge Hydrostatic Test Water (Ohio NPDES General Permit OHH000004). These individuals are my duly authorized representatives to sign all required reports or other information that may be requested by the Ohio EPA Director.

“Facilities Project Manager, Owner  
Project Engineer  
Environmental Compliance Coordinator  
Supervisor Environmental  
Qualified Inspection Personnel”

Signature George K. Smith  
Printed Name George K. Smith  
Title Director Gas Operations  
Date 5-10-23

This Operator Certification must be signed by a responsible corporate officer or delegated authority.

## CERTIFICATIONS

*Owner/Developer Certification (must be signed by president, vice-president or equivalent or ranking elected official)*

I certify under penalty of law that this document and all attachments were prepared under my direction or supervision in accordance with a system designed to assure that qualified personnel properly gathered and evaluated the information submitted. Based on my inquiry of the person or persons who manage the system or those persons directly responsible for gathering the information, the information submitted is, to the best of my knowledge and belief, true, accurate and complete. I am aware that there are significant penalties for submitting false information, including the possibility of fine and imprisonment for knowing violations.

\_\_\_\_\_  
Signature

\_\_\_\_\_  
Date

\_\_\_\_\_  
Printed Name

\_\_\_\_\_  
Title

*If authorization is no longer accurate because of a different individual or position has responsibility for the overall operation of the Project, a new authorization must be submitted to the Director prior to, or together with any reports, information, or applications to be signed by an authorized representative.*

*Contractor(s) Certification (must be signed by president, vice-president or equivalent or ranking elected official)*

I certify under penalty of law that I have reviewed this document, any attachments, and the SWP3 referenced above. Based on my inquiry of the construction site owner/developer identified above, and/or my inquiry of the person directly responsible for assembling this SWP3, I believe the information submitted is accurate. I am aware that this SWP3, if approved, makes the above-described construction activity subject to the Ohio NPDES General Permit, and that certain activities on-site are thereby regulated. I am aware that there are significant penalties, including the possibility of fine and imprisonment for knowing violations and for failure to comply with these permit requirements.

\_\_\_\_\_  
Primary Contractor Name

\_\_\_\_\_  
\_\_\_\_\_  
Primary Contractor Address

\_\_\_\_\_  
Signature

\_\_\_\_\_  
Date

\_\_\_\_\_  
Printed Name

\_\_\_\_\_  
Title

\_\_\_\_\_  
Subcontractor Name

\_\_\_\_\_  
\_\_\_\_\_  
Subcontractor Address

\_\_\_\_\_  
Signature

\_\_\_\_\_  
Date

\_\_\_\_\_  
Printed Name

\_\_\_\_\_  
Title



**OHIO GENERAL PERMIT AUTHORIZATION FOR STORMWATER  
DISCHARGES ASSOCIATED WITH CONSTRUCTION ACTIVITY UNDER  
THE NPDES STORMWATER POLLUTION PREVENTION PLAN**

**THE EAST OHIO GAS COMPANY, d/b/a DOMINION ENERGY OHIO  
PIR 2788 – Apple Creek  
Wooster Township, Wayne County, Ohio**

**TABLE OF CONTENTS**

<b>SECTION</b>	<b>Page</b>
<b>EXECUTIVE SUMMARY .....</b>	<b>v</b>
<b>1.0 PERMIT REQUIREMENTS.....</b>	<b>1</b>
<b>2.0 STORMWATER POLLUTION PREVENTION PLAN .....</b>	<b>2</b>
2.1    SITE/PROJECT DESCRIPTION AND LOCATION/SETTING .....	3
2.2    PRE-CONSTRUCTION AND POST-CONSTRUCTION SITE CONDITIONS ....	4
2.3    EXISTING SOIL DATA .....	4
2.4    STEEP SLOPES.....	4
2.5    PRIOR LAND USES .....	4
2.6    RECEIVING STREAMS OR SURFACE WATERS .....	4
2.7    IMPLEMENTATION SCHEDULE .....	6
2.8    SITE MAPPING .....	8
<b>3.0 CONTROLS .....</b>	<b>9</b>
3.1    PRESERVATION METHODS.....	9
3.2    EROSION CONTROL PRACTICES .....	9
3.3    RUNOFF CONTROL PRACTICES.....	12
3.4    SURFACE WATER PROTECTION.....	13
3.5    WETLAND PRACTICES.....	14
3.6    SEDIMENT CONTROL PRACTICES .....	15
3.7    POST-CONSTRUCTION STORMWATER MANAGEMENT (PCSM).....	17
3.8    OTHER CONTROLS .....	17
3.9    MAINTENANCE .....	20
3.10   INSPECTIONS .....	21

<b>4.0</b>	<b>APPROVED STATE OR LOCAL PLANS.....</b>	<b>23</b>
<b>5.0</b>	<b>EXCEPTIONS.....</b>	<b>24</b>
<b>6.0</b>	<b>NOTICE OF TERMINATION REQUIREMENTS.....</b>	<b>25</b>

## LIST OF TABLES

<b>Table</b>		<b>Page</b>
1	Permanent Stabilization .....	8
2	Temporary Stabilization .....	8
3	Summary of Onsite Streams/Rivers .....	12
4	Summary of Onsite Wetlands.....	13
5	Required Spacing and Materials for Trench Plugs.....	15

## LIST OF APPENDICES

A	Site Location Maps (highway, topographic, watershed)
B	Soils Map and Table Identifying Soil Types and Characteristics
C	Detailed Erosion and Sediment Control Location Drawings
D	Site Drawing Checklist and Logs
E	Corrective Action Log
F	Typical Upland Erosion and Sediment Control Plan Drawings
G	Typical Stream Crossing Drawings
H	Typical Wetland Crossing Drawing
I	NOI Application Documentation
J	Concrete Washout Typical Detail
K	SWP3 Inspection Forms
L	Seeding Specifications
M	Pre-Construction and Post-Constriction Runoff Volumes & Peak Rate Calculations



## LIST OF DEFINITIONS

BMP	Best Management Practice
C&DD	Construction and Demolition Debris
Director	Director of the Ohio Environmental Protection Agency
E&S	Erosion and Sediment
EPA	Environmental Protection Agency
General Permit	General Permit for Stormwater Discharges Associated with Construction Activities Under the National Pollutant Discharge Elimination System Permit No. OHC000006, effective April 23, 2023, expires April 22, 2028.
HUC	Hydrologic Unit Code
MS4	Municipal Separate Storm Sewer System
NOI	Notice of Intent
NOT	Notice of Termination
NPDES	National Pollutant Discharge Elimination System
OAC	Ohio Administrative Code
ORAM	Ohio Rapid Assessment Method
ORC	Ohio Revised Code
PCSM	Post-Construction Stormwater Management
PTI	Permit to Install
SPCC	Spill Prevention Control and Countermeasures
SWP3	Stormwater Pollution Prevention Plan
VAP	Voluntary Action Program

## EXECUTIVE SUMMARY

The purpose of this Stormwater Pollution Prevention Plan (SWP3) is to present procedures that will be followed during construction activities to minimize adverse impacts due to sedimentation and potential environmental pollutants resulting from storm water runoff and to reduce sediment and environmental pollutant runoff after Project completion. This SWP3 sets forth procedures to be followed during construction activities for The East Ohio Gas Company, d/b/a Dominion Energy Ohio (Dominion Energy), Pipeline Infrastructure Replacement (PIR) project, PIR 2788 – Apple Creek (Project), located in Wooster Township, Wayne County, Ohio. The procedures developed in this plan must be implemented throughout the duration of the Project.

Dominion Energy will be responsible for the development, implementation, and enforcement of this plan. Dominion Energy personnel may designate qualified representatives such as environmental inspectors or contractors to ensure the provisions of this permit are properly employed.

This document was prepared in accordance with the following documents: Ohio Department of Natural Resources, Division of Soil and Water Conservation "Rainwater and Land Development" Manual Third Edition 2006, Updated 11-6-14; Ohio Environmental Protection Agency (EPA), Authorization for Stormwater Discharges Associated with Construction Activity Under the National Pollutant Discharge Elimination System Permit OHC000006; and Ohio EPA Stormwater Program Website, <http://www.epa.state.oh.us/dsw/storm/index.aspx>.

This plan covers all new and existing discharges composed entirely of stormwater discharges associated with construction activity that enter surface waters of the State or a storm drain leading to surface waters of the State. Construction activities include any clearing, grading, excavating, grubbing and/or filling activities that disturb one (1) or more acres of land.

## 1.0 PERMIT REQUIREMENTS

The purpose of this SWP3 is to present procedures that will be followed during construction activities to minimize adverse impacts due to sedimentation resulting from storm water runoff and to reduce sediment runoff after Project completion. Operators who intend to obtain initial coverage for a stormwater discharge associated with construction activity under this General Permit Authorization for Storm Water Discharges Associated with Construction Activity Under the National Pollutant Discharge Elimination System (NPDES), Ohio EPA Permit Number OHC000006 (effective April 23, 2023 and expires April 22, 2028 (General Permit)) must submit a complete and accurate Notice of Intent (NOI) application form and appropriate fee at least 21 days prior to the commencement of construction activity. The completed NOI application is provided in **Appendix I**.

Dominion Energy must make NOIs and SWP3s available upon request of the Director of Ohio EPA; local agencies approving sediment and erosion control plans, grading plans or stormwater management plans; local governmental officials, or operators of municipal separate storm sewer systems (MS4s) receiving drainage from the permitted site.

## 2.0 STORMWATER POLLUTION PREVENTION PLAN

This SWP3 was prepared in accordance with sound engineering and/or conservation practices by a professional experienced in the design and implementation of standard erosion and sediment controls and stormwater management practices addressing all phases of construction. This SWP3 was prepared by Dominion Energy and Environmental Consulting & Technology, Inc.

This SWP3 has identified potential sources of pollution which may reasonably be expected to affect the quality of stormwater discharges associated with construction activities. This SWP3 describes and ensures the implementation of Best Management Practices (BMPs) that reduce the pollutants in stormwater discharges during construction and pollutants associated with post-construction activities to ensure compliance with Ohio Revised Code (ORC) Section 6111.04, Ohio Administrative Code (OAC) Chapter 3745-1 and the terms and conditions of the General Permit. In addition, the SWP3 must conform to the specifications of the Ohio Rainwater and Land Development Manual.

### Plan Availability

Dominion Energy must provide a copy of this SWP3 within seven (7) days upon written request by any of the following: The Director or the Director's authorized representative; a local agency approving sediment and erosion plans, grading plans or stormwater management plans; or; in the case of a stormwater discharge associated with construction activity which discharges through a municipal separate storm sewer system with an NPDES permit, to the operator of the system. A copy of the NOI and letter granting permit coverage under this General Permit must also be made available at the site.

All NOIs, General Permit approval for coverage letters, and SWP3s are considered reports that must be available to the public in accordance with the Ohio Public Records law. Dominion Energy must make documents available to the public upon request or provide a copy at public expense, at cost, in a timely manner. However, Dominion Energy may claim to Ohio EPA any portion of a SWP3 as confidential in accordance with Ohio law.

### Plan Revisions and Amendments.

The Director or authorized representative, and/or any regulatory authority associated with approval of this plan, may notify Dominion Energy at any time that the SWP3 does not meet one (1) or more of the minimum requirements. Within ten (10) days after such notification from the Director (or as otherwise provided in the notification) or authorized representative, and/or any regulatory authority associated with approval of this plan, Dominion Energy must make the required changes to the SWP3 and, if requested, must submit to Ohio EPA, and/or other regulatory authority, the revised SWP3 or a written certification that the requested changes have been made. Dominion Energy must also amend the SWP3 whenever there is a change in site design, construction, operation, or maintenance that requires the installation of BMPs or modifications to existing BMPs.



## Duty to Inform Contractors and Subcontractors.

Dominion Energy must inform all contractors and subcontractors who will be involved in the implementation of the SWP3 of the terms and conditions of the General Permit and/or other approval from a regulatory authority. Dominion Energy must maintain a written document containing the signatures of all contractors and subcontractors involved in the implementation of the SWP3 as proof acknowledging that they reviewed and understand the conditions and responsibilities of the SWP3. The written document must be created and signatures of each individual contractor must be obtained prior to their commencement of work on the construction site. Certification statements for contractors and subcontractors can be found at the beginning of this document.

### **2.1 SITE/PROJECT DESCRIPTION AND LOCATION/SETTING**

Dominion Energy is proposing to install approximately 3,900 feet of replacement natural gas pipeline (twelve [12]-inch diameter) and conduct any necessary abandonment activities under Dominion Energy's PIR Program. The purpose of this program is to replace existing pipe to ensure the safety and reliability of pipeline operations.

The PIR 2788 Project is located within Wooster Township, Wayne County, along N. Hillcrest Drive, in an existing sixty (60)-ft wide utility easement which originates at N. Hillcrest Drive and extends northeast to S. Geyers Chapel Road, and in a newly acquired sixty (60)-foot wide easement which originates as a private drive on the east side of N. Hillcrest Drive and extends east to Apple Creek. At intersections with roads with no proposed mainline replacement, small portions of pipeline may be installed to "tie in" the new pipeline to existing pipelines. Along any portions of abandoned pipeline, small areas of excavation may occur to allow the line to be purged and cut and capped. The need for any laydown and/or material storage areas will be determined by the selected construction contractor. The Project area is easily accessible from public roads as well as from a residential drive off N. Hillcrest Drive and a farm access road off S. Geyers Chapel Road.

The scope of work is to install and abandon sections of natural gas pipeline; as well as a permanent gravel access to an underground drip tank with an above ground 2" siphon and four (4) bollards. No other utilities will be constructed. The construction of new buildings is not included in the scope of work. Disturbance within the Project area will be minimized as much as possible. The area environmentally reviewed to facilitate the Project is approximately 13.0 acres. Approximately 5.4 acres will be temporarily disturbed due to excavation, filling, grading, and installation of erosion control measures. The 5.4 acres will be disturbed in phases.

The Project area is located in residential, agricultural, and undeveloped land within the Walhonding River drainage basin (Hydrologic Unit Code [HUC] 05040003). The Project area has undulating elevations. Six (6) streams and one (1) wetland are located in the Project area.

The maps included in **Appendix A** depict the location of the Project on a roadway map, U.S. Geological Survey Topographic Map, and a watershed map.

## 2.2 PRE-CONSTRUCTION AND POST-CONSTRUCTION SITE CONDITIONS

The Project does create approximately 0.20 acre of impervious area as a result of the development of the gravel access road to the 2” siphon; therefore, there will be a permanent increase in stormwater runoff. Pre-Construction and Post-Construction runoff volume and peak rate calculations are provided in **Appendix M**. All other areas disturbed by the Project will be restored to their pre-construction material, condition, and contours.

*Table 1: Runoff Coefficients Based on Land Use*

Land Use	Runoff Coefficient
Industrial and Commercial	0.8
High Density Residential (more than eight dwellings per acre)	0.5
Medium Density Residential (four to eight dwellings per acre)	0.4
Low Density Residential (less than four dwellings per acre)	0.3
Open Space and Recreational Areas	0.2

## 2.3 EXISTING SOIL DATA

The United States Department of Agriculture, Natural Resources Conservation Service (NRCS) Soil Survey was utilized to identify soil map units within the Project site. The primary soils types located within the Project include Tioga silt loam, occasionally flooded (Tg); Canfield silt loam, 2 to 6 percent slopes (CdB); and Wooster-Riddles silt loams, 6 to 12 percent slopes (WuC). A copy of the Soil Survey for the Project and a table identifying the soil types and characteristics (drainage capacity, depth to water table, K factor rating, etc.) are provided in **Appendix B**.

## 2.4 STEEP SLOPES

The Project area does exhibit steep/critical slopes. At those areas exhibiting steep/critical slopes, erosion and sediment controls appropriate for use were selected.

## 2.5 PRIOR LAND USES

Prior land uses for the Project site includes residential, agricultural, and undeveloped land.

## 2.6 RECEIVING STREAMS OR SURFACE WATERS

The Project is located within the Apple Creek subwatershed (HUC12 05040003 0602) of the Apple Creek-Killbuck Creek watershed (HUC10 05040003 06), within the Walhonding River watershed (HUC8 05040003). The first named receiving stream for the Project is Apple Creek, which is located in the Project area. Apple Creek drains into Killbuck Creek which drains south into the Walhonding River. The Walhonding River is a tributary of the Muskingum River which drains to the Ohio River. A map depicting where the Project is located within a watershed setting is included in **Appendix A**. Any rivers, streams, wetlands, and any significant ponds or ditches crossed by the Project have been included on the maps in **Appendix C**.

The following water bodies are located within the Project area: Wetland A, Stream 1 (Apple Creek), Stream 2, Stream 3, Stream 4, Stream 5, and Stream 6. Wetland A, Stream 1 (Apple Creek), Stream 4, Stream 5, and Stream 6 will be open cut and temporarily impacted. Stream 2 will also be impacted due to the installation of a temporary culvert for equipment crossing. Temporary impacts to these resources are anticipated to be authorized under Nationwide Permit #12. Stream 3 is set away from the Project work area. No impact will occur to this stream.

Wetland A is a large (over one [1] acre) riparian wetland that abuts Stream 1 (Apple Creek) within the Project area. Wetland A has forested, shrub, and emergent dominated portions. Emergent portions of Wetland A are regularly mowed and cleared to maintain farm access areas. Wetland A drains directly into Stream 1 (Apple Creek).

Stream 1 (Apple Creek) is a large perennial stream that flows east to west across the Project area. Dominant substrate types within Stream 1 (Apple Creek) include cobble and gravel. Although the assessed reach of Stream 1 (Apple Creek) is protected within a forested riparian area, the surrounding agricultural landscape likely influences sedimentation and nutrient loads within the stream. Apple Creek has been designated as Warmwater Habitat by the OEPA and the nearest sampling station #R03W47 was in partial attainment per the 2018 Integrated Water Quality Monitoring and Assessment Report.

Stream 2, an ephemeral stream, drains south through the Project area along the western side of S. Geyers Chapel Road. Stream 2 is also culverted beneath a farm access road immediately north of its confluence with Stream 1 (Apple Creek) within the eastern Project area. Substrates of Stream 2 are dominated by silt and clay/hardpan. The stream has been channelized to run parallel to the road, and water quality is likely heavily influenced by stormwater from the adjacent roadway and agricultural fields.

Stream 3, an ephemeral stream, drains northwest through the Project area. The stream has been channelized to run underneath the existing pipeline easement through a culvert and water quality is likely heavily influenced by stormwater from the surrounding residential area and agricultural fields. Substrates of Stream 3 are dominated by gravel, cobble, and sand.

Stream 4 is an intermittent stream located in the western Project area along a potential site access route. Stream 4 drains north through the Project area and Wetland A into Stream 1 (Apple Creek). Stream 4 has been heavily channelized and is culverted beneath an existing field access road. Dominant substrate types within Stream 4 include gravel and clay/hardpan. Stream 4 is likely highly influenced by stormwater from the adjacent fallow fields/maintained lawn areas.

Stream 5 is an ephemeral stream that originates in western portions of the Project area and flows north towards Stream 1 (Apple Creek) where it eventually loses bed and bank within portions of Wetland A. Dominant substrate types of Stream 5 include cobble and clay/hardpan.

Stream 6 is an ephemeral stream captured in a roadside ditch along the western edge of N. Hillcrest Drive. Dominant substrate types in Stream 6 include boulder and cobble. Stream 6 is heavily impacted by stormwater runoff from the adjacent roadway.

Floodplain associated with Stream 1 (Apple Creek) is located within the Project area. Temporary impact to this floodplain is anticipated due to construction and coordination for work within the floodplain will be conducted prior to project commencement.

The Ohio EPA conducts periodic surveys to collect water quality data on Ohio's streams and rivers. The data are incorporated into the Ohio Integrated Water Quality Monitoring and Assessment Report. The watershed monitoring data closest to the Project area indicates that Apple Creek at Ely Road is in partial attainment for Aquatic Life Use. The Watershed Assessment indicates that the watershed, as a whole, is impaired for recreational use. The water is not utilized for drinking water supply.

The project is located in Wayne County which holds a MS4 Stormwater General Permit (3GQ00139\*BG).

Dedicated asphalt and/or concrete batch plant discharges are not applicable to this Project.

## **2.7 IMPLEMENTATION SCHEDULE**

A general implementation schedule providing the sequence of major construction operations is provided below. Construction activities are expected to be initiated and completed in 2024. The specific start date will be determined by the receipt of all applicable permits and the selected construction contractors' schedule. The completion date may be affected by weather conditions. Surface stabilization at the Project site is expected to take place incrementally, as construction progresses. Once all land disturbing activities have been completed, the site must be permanently stabilized. Throughout the life of the Project, construction logs must be kept to record major dates of grading, excavating, and stabilizing.

### **1 - SITE PREPARATION FOR ENTIRE PROJECT (To be determined by the contractor)**

- Mobilization.
- Survey and stake existing pipeline and limits of construction.
- Flag/field mark wetland areas, as necessary.
- Installation/improvement to construction entrances, and installation of silt fence or other BMPs designated to control storm water at the project boundary.
- Install gravel on dirt roads, and fill-in rutted areas on existing gravel roads.



## **2 - SITE PREPARATION FOR EACH JOB (To be determined by the contractor)**

- Install BMPs (see Section 3.0) for access roads/equipment crossings at stream crossings and wetland crossings.
- Begin clearing and grubbing of the site.
- Install temporary runoff controls and erosion control devices where needed.
- Conduct grading activities, as needed.
- Monitor all erosion and sediment controls

## **3 - MAJOR CONSTRUCTION ACTIVITIES (To be determined by the contractor)**

- Excavation.
- Implement BMPs (See Section 3.0) for dewatering (if required).
- Monitor all erosion and sediment controls

## **4 - RESTORATION (To be determined by the contractor)**

- Restore grade to preconstruction contours and install permanent runoff controls, where needed.
- Installation of concrete washout (if required)
- Apply seed and mulch to all disturbed upland areas.
- Install erosion control blankets or turf matting on steep slopes.
- Monitor all erosion and sediment controls

## **5 - POST-CONSTRUCTION MONITORING (On-going until 70 percent cover reached)**

- Removal of concrete washout and disposal of washout material
- Monitor adequacy of erosion control practices.
- Remove temporary erosion and sediment controls and runoff controls once 70 percent uniform vegetative growth is achieved.
- Submit Notice of Termination.

## 2.8 SITE MAPPING

The scope of this Project is to install replacement natural gas pipeline, conduct activities associated with pipeline abandonment, and install a gravel access road to a new underground drip tank. No other utilities, buildings, roads, or parking facilities will be constructed.

Project site location maps are provided in **Appendix A**. The Soil Survey map for the Project is provided in **Appendix B**. The Project specific erosion and sediment control location drawings (in **Appendix C**) depict the limits of earth-disturbing activity, existing and proposed contours; surface water locations, relation to existing buildings and roads, the location of all erosion and sediment control measures, and the location of all construction entrances. The site drawing checklist and logs are included in **Appendix D**. Typical erosion and sediment control drawings for all sediment and erosion controls practices are also included in **Appendices F, G, and H**.

### 3.0 CONTROLS

To the extent practicable, the locations of temporary and permanent stormwater BMPs to be implemented for the Project site are shown on the drawings provided in **Appendix C**. [Some BMP locations (construction entrances, ingress/egress points, etc.) will be determined in the field upon discussion with the selected construction contractor and will be noted on the project drawings (in **Appendix A, B, and/or C**, as appropriate) at that time. The construction contractor will complete the “Site Drawing Checklist” (**Appendix D**) verifying the inclusion of these features.] The BMPs will be implemented in accordance with the Typical Drawings provided in **Appendices F, G, and H**. The erosion, sediment, and stormwater management practices to be implemented are in accordance with the standards and specification in the current edition of Ohio’s Standards for Stormwater Management, Land Development and Urban Stream Protection, Rainwater and Land Development Manual, Third Edition 2006 updated November 6, 2014.

#### 3.1 PRESERVATION METHODS

In order to preserve the existing natural condition as much as feasible, the Project will avoid clearing and grubbing where feasible, minimize the amount of soil and vegetation disturbances by phasing construction operations, and minimize disturbances to surface waters. The recommended buffer along any surface water of the state to be undisturbed is fifty (50) feet measured from the ordinary high water mark of the surface water.

Disturbance within the Project area will be minimized as much as possible. Approximately 5.4 acres will be temporarily disturbed. The 5.4 acres will be disturbed in phases.

Separation of the topsoil from the subsoil will generally be performed at residential properties, any wetlands and streams, and agricultural lands. The backfill material returned to the excavation will consist of the same material removed from the excavation, to the extent practicable.

#### 3.2 EROSION CONTROL PRACTICES

Erosion control measures provide cover over disturbed soils in order to minimize erosion. Disturbed areas must be stabilized after construction activities. Erosion control measures likely employed for the Project include: phased disturbance, clearing and grubbing, construction entrances, dust control, matting (Temporary Rolled Erosion Control Product), mulching, topsoiling, temporary seeding, permanent seeding, and sodding. Erosion Control Measures will be in accordance with the Rainwater and Land Development Manual. Typical drawings for these erosion control measures are provided in **Appendix F**.

Permanent stabilization is defined as the establishment of permanent vegetation, decorative landscape mulching, matting, sod, rip rap and landscaping techniques to provide permanent erosion control on areas where construction operations are complete or where no further disturbance is expected for at least one (1) year.

Temporary stabilization is defined as the establishment of temporary vegetation, mulching, geotextiles, sod, preservation of existing vegetation and other techniques capable of quickly

establishing cover over disturbed areas to provide erosion control between construction operations.

Final stabilization is defined and achieved when all soil disturbing activities at the site are complete and disturbed surfaces are covered with new structures, pavement, a uniform perennial vegetative cover (e.g., evenly distributed, without large bare areas) with a density of at least seventy (70) percent cover, or other equivalent stabilization measures (such as the use of landscape mulches, rip-rap, gabions or geotextiles) have been employed. In addition, all temporary erosion and sediment control practices are removed and disposed of and all trapped sediment is permanently stabilized to prevent further erosion.

Disturbed areas will be stabilized following completion of construction activities as specified in **Tables 1 and 2** below and in accordance with the site layout maps and detail sheets provided in **Appendix C**.

*Table 1: Permanent Stabilization*

<b>Area Requiring Permanent Stabilization</b>	<b>Time Frame to Apply Erosion Controls (Stabilization)</b>
Any areas that will lie dormant for one (1) year or more.	Within seven (7) days of the most recent disturbance.
Any areas within 50 feet of a surface water of the State and at final grade.	Within two (2) days of reaching final grade.
Any other areas at final grade.	Within seven (7) days of reaching final grade within that area.

*Table 2: Temporary Stabilization*

<b>Area Requiring Temporary Stabilization</b>	<b>Time Frame to Apply Erosion Controls (Stabilization)</b>
Any disturbed areas within 50 feet of a surface water of the State and not at final grade.	Within two (2) days of the most recent disturbance if the area will remain idle for more than fourteen (14) days.
For all construction activities, any disturbed areas that will be dormant for more than fourteen (14) days but less than one (1) year, and not within 50 feet of a surface water of the State.	Within seven (7) days of the most recent disturbance within the area.  For residential subdivisions, disturbed areas must be stabilized at least seven (7) days prior to transfer of permit coverage for the individual lot(s).
Disturbed areas that will be idle over winter.	Prior to the onset of winter weather.

Clearing and Grubbing: Clearing and grubbing is the removal of trees, brush, and other unwanted material in order to develop land for other uses or provide access for site work. Clearing generally describes the cutting and removal of above ground material, while grubbing is the removal of roots, stumps, and other unwanted material below existing grade. Clearing and grubbing includes the proper disposal of materials and the implementation of BMPs in order to minimize exposure of soil to erosion and causing downstream sedimentation.



Construction Entrance: A construction entrance is a method of erosion control that is used to reduce the amount of mud tracked off-site with construction traffic. A construction entrance is a stabilized pad of stone underlain with a geotextile. These entrances are located at points of ingress/egress of construction traffic.

Dust Control: Dust control is a method of erosion control that involves preventing or reducing dust from exposed soils or other sources during land disturbing, demolition, and construction activities to reduce the presence of airborne substances which may present health hazards, traffic safety problems, or harm animal or plant life.

Matting/Temporary Rolled Erosion Control Product (TRECPE): TRECPEs are a method of erosion control which is a degradable manufactured material used to stabilize easily eroded areas while vegetation becomes established. Temporary Rolled Erosion Control Products are degradable products composed of biologically, photo chemically, or otherwise degradable materials. TRECPEs consist of erosion control netting, open weave textiles, and erosion control blankets and mattings. These products reduce soil erosion and assist vegetative growth by providing temporary cover from the erosive action of rainfall and runoff while providing soil-seed contact.

Mulching: Mulching is a temporary or permanent method of erosion control used to protect exposed soil or freshly seeded areas from the direct impact of precipitation by providing a temporary surface cover. Mulch also helps establish vegetation by conserving moisture and creating favorable conditions for seeds to germinate. Mulch must be used liberally throughout construction to limit the areas that are bare and susceptible to erosion. Mulch can be used in conjunction with seeding to establish vegetation or by itself to provide erosion control when the season does not allow grass to grow. Mulch and other vegetative practices must be applied on all disturbed portions of construction-sites that will not be re-disturbed for more than fourteen (14) days.

Permanent Seeding: Permanent seeding is a method of erosion control used to permanently stabilize soil on construction sites where land-disturbing activities, exposed soil, and work has been completed or is not scheduled for more than twelve (12) months. Permanent seeding must be applied to any disturbed areas or portions of construction sites at final grade. Permanent seeding must not be delayed on any one portion of the site at final grade while construction on another portion of the site is being completed. Permanent seeding must be completed in phases, if necessary. Permanent vegetation is used to stabilize soil, reduce erosion, prevent sediment pollution, reduce runoff by promoting infiltration, and provide stormwater quality benefits offered by dense grass cover.

Phased Disturbance: Phased disturbance is a method of erosion control that limits the total amount of grading at any one time and sequences operations so that at least half the site is either left as undisturbed vegetation or re-stabilized prior to additional grading operations. This approach actively monitors and manages exposed areas so that erosion is minimized and sediment controls can be more effective in protecting aquatic resources and downstream landowners.

Sodding: Sodding is a method of erosion control that utilizes rolls or mats of turf grass to provide immediate stabilization to bare soils. It is especially useful in highly erosive areas such as drainage

ways and on slopes that will be mowed. Sod may be used where immediate cover is required or preferred and where vegetation will be adequate stabilization such as minor swales, around drop inlets, and lawns.

Temporary Seeding: Temporary seeding is a method of erosion control used to temporarily and quickly stabilize soil on construction sites where land-disturbing activities have been initiated but not completed. Appropriate rapidly growing annual grasses or small grains must be planted on the disturbed areas. Temporary seeding effectively minimizes the area of a construction site prone to erosion and must be used everywhere the sequence of construction operations allows vegetation to be established. Temporary seeding must be applied on exposed soil where additional work (grading, etc.) is not scheduled for more than fourteen (14) days. Mixes to be applied are specific to the time of year the seeding will take place and the location of the Project within the state.

Topsoiling: During grading operations, topsoil and the upper most organic layer of soil will be stripped and stockpiled and then subsequently replaced on the newly graded areas. Topsoil provides a more suitable growing medium than subsoil or on areas with poor moisture, low nutrient levels, undesirable pH, or in the presence of other materials that would inhibit establishment of vegetation. Replacing topsoil helps plant growth by improving the water holding capacity, nutrient content, and consistency of the soils.

### **3.3 RUNOFF CONTROL PRACTICES**

Temporary and permanent runoff control is important on development sites to minimize on-site erosion and to prevent off-site sediment discharge. Runoff control methods likely implemented for this Project include dewatering measures, compost sock check dams, and waterbars. Runoff control measures will be in accordance with Chapter 4 and 5 of the Rainwater and Land Development Manual.

Dewatering Measures. Dewatering consists of providing an area for receiving and treating surface runoff and groundwater pumped from excavation or work areas prior to being released off the site, such as desilting basins or sediment traps. For project areas without these detention features, dewatering typically consists of the use of filter devices (e.g. filter bags) to treat and release water removed from excavation. Filter bags should discharge to an upland location if possible. These practices reduce sediment impacts to downstream water resources.

Compost Sock Check Dam. Compost sock check dams are dams constructed in swales, grassed waterways or diversions comprised of a compost filter sock (staked in place). Compost sock check dams reduce the velocity of concentrated flows thereby reducing erosion within the swale or waterway.

Waterbar. A waterbar is a diversion constructed across the slope of an access road or utility right-of-way. Waterbars are used to reduce concentrated runoff on unpaved road surfaces, thus reducing water accumulation and erosion gullies from occurring. Waterbars divert runoff to road side swales, vegetated areas, or settling ponds.

### 3.4 SURFACE WATER PROTECTION

The Project area encompasses six (6) streams and one (1) wetland (see Section 2.6). Waters must be protected by avoiding crossing of streams and wetlands where feasible and using sediment and erosion control practices to prevent sediment-laden runoff from reaching the surface waters.

Surface Waters of the State Protection. If construction activities disturb areas adjacent to surface waters of the State, structural practices must be designed and implemented onsite to protect all adjacent surface waters of the State from the impacts of sediment runoff. No structural sediment controls (e.g., the installation of silt fence or a sediment settling pond) must be used in a surface water of the State. For all construction activities immediately adjacent to surface waters of the State, it is recommended that a setback of at least 25 feet, as measured from the ordinary high water mark of the surface water, be maintained in its natural state as a permanent buffer.

Where impacts within this setback area are unavoidable due to the nature of the construction activity (e.g., stream crossings for roads or utilities), the Project must be designed such that the number of crossings and the width of the disturbance within the setback area are minimized.

In order to minimize the amount of disturbance and sedimentation caused by work at wetland crossings, every effort will be made to minimize impacts. Movement across waters will be limited to necessary equipment only. BMPs for vehicle crossing of streams and wetlands will be utilized when practical. Dominion will employ a typical temporary equipment crossing at each crossing location. These crossing methods are found on the typical drawings in **Appendices G and H**. All wetland crossings will be restored to pre-construction grades, contours, and, when feasible, vegetation type. Dominion will obtain all necessary wetland crossing permits from federal and state regulatory agencies. Summaries of the onsite surface waters and any impacts are provided in **Tables 3 and 4**.

Surface Water Utility Crossing. Surface water utility crossings include pipeline, power line, or road construction projects that cross streams, rivers, or wetlands. Measures used to minimize damage from the construction of utilities across streams and wetlands start in the planning stages of a project and continue through site restoration.

Temporary Surface Water Crossing. A temporary surface water crossing provides construction traffic temporary access across a surface water while reducing the amount of disturbance and sediment pollution. It is a temporary practice which includes restoring the crossing area after construction. The typical kinds of surface water crossings are: bridges, timber mats, culverts and fords. Each has specific applications and each is designed to minimize surface water damage by leaving wetland areas and stream banks stable and vegetated.

Table 3: Summary of Onsite Streams/Rivers

Stream ID	Stream Length (lf) within Project Area	Bankfull Width (feet)	Flow Regime	Substrate Type(s)	Designation/ Classification <sup>1</sup>	Crossing Method <sup>2</sup>	Impacts - Upstream to Downstream Length (lf)	Impacts- Trench Crossing Length (lf)
1 (Apple Creek)	180	48	Perennial	Cobble, gravel	Warm Water Habitat	Open Cut	52	48
2	155	2	Ephemeral	Silt, clay/hardpan	Modified Class I PHW1	Culvert	68	0 <sup>3</sup>
3	83	6	Ephemeral	Gravel/sand	Modified Class II PHW	Avoid	0	0
4	93	9	Intermittent	Gravel, clay/hardpan	Modified Class II PHW	Open Cut	44	9
5	83	4	Ephemeral	cobble, clay/hardpan	Class II PHW	Open Cut	9	4
6	673	4	Ephemeral	boulder, cobble	Modified Class II PHW	Open Cut	10	4

Notes:

- 1 Designation determination made using Quality Habitat Evaluation Index (QHEI) and Headwater Habitat Evaluation Index (HHEI) scoring methods.
- 2 Project Managers must approve changes to crossing methods.
- 3 Impacts to Stream 2 will involve the installation of a temporary culvert for equipment access and will not involve trenching.

Table 4: Summary of Onsite Wetlands

Wetland ID	Vegetation Cover Type within the Project Area	Area within ROW (acres)	ORAM <sup>1</sup> Category	Crossing Method <sup>2</sup>	Impact Area (acres)	Impacts Length of Wetland Crossing (lf)
A	PEM/PSS/PFO	2.380	2	Open Cut	0.924	671

Notes:

- 1 Ohio Rapid Assessment Method
- 2 Project Managers must approve changes to crossing methods.

### 3.5 WETLAND PRACTICES

Concentrated stormwater runoff from proposed BMPs to natural wetlands must be converted to diffuse flow before the runoff enters the wetlands. The flow must be released such that no erosion occurs downslope. Level spreaders may need to be placed in series, particularly on steep sloped sites, to ensure non-erosive velocities. Other structural BMPs may be used between stormwater features and natural wetlands, in order to protect the natural hydrology, hydroperiod, and wetland flora. If Dominion Energy proposes to discharge to natural wetlands, a hydrologic analysis must be performed. Dominion Energy must attempt to match the pre-development hydroperiods and hydrodynamics that support the wetland. Dominion Energy must assess whether their construction activity will adversely impact the hydrologic flora and fauna of the wetland. Practices such as vegetative buffers, infiltration basins, conservation of forest cover, and the preservation of intermittent streams, depressions, and drainage corridors may be used to maintain wetland hydrology.



### 3.6 SEDIMENT CONTROL PRACTICES

All Project activities will occur within the areas indicated on site drawings in **Appendix C**. All Sediment Control Devices will match those indicated on the mapping in **Appendix C**. Minor adjustments to control devices (type, location, etc.) deemed necessary to maintain compliance can be made on the project mapping. The location of any laydown and/or material storage areas will be determined in the field upon discussion with the selected construction contractor and will be noted on the project site drawings at that time. The “Site Drawing Checklist” (**Appendix D**) will be completed, verifying the inclusion of these features or minor adjustments. Any necessary mainline to mainline tie-ins (at intersections with streets with no proposed mainline replacement) will also be noted on the drawings. Construction activities for this Project will be limited to the Limit of Disturbance of 5.4 acres. Sediment Control Practices must treat runoff allowing sediments to settle and/or divert flows away from exposed soils or otherwise limit runoff from exposed areas. Structural practices must be used to control erosion and trap sediment from a disturbed site. Methods of control that may be used include, among others: silt fence, storm drain inlet protection, filter socks, and trench plugs. All sediment control practices must be capable of ponding runoff in order to be considered functional. Earth diversion dikes or channels alone are not considered a sediment control practice unless those are used in conjunction with a sediment settling pond. Sediment Controls must be designed, installed, and maintained in accordance with the requirements set forth in Chapter 6 of the Ohio Rainwater and Land Development Manual, and/or Ohio General Permit OHC000006. Dominion Energy discourages the use of haybales unless utilized as a secondary treatment element in conjunction with another erosion and sediment control(s) and only if approved by Dominion Energy.

Timing. Sediment control structures must be present, as indicated or otherwise deemed to be necessary, and must be functional throughout the course of earth disturbing activity. Sediment basins and perimeter sediment barriers must be implemented prior to grading and within seven (7) days from the start of grubbing. Sediment control structures must continue to function until the up-slope development area is restabilized. As construction progresses and the topography is altered, appropriate controls must be constructed or existing controls altered to address the changing drainage patterns.

Silt Fence. Silt fence is a temporary method of sediment control that is used in sheet-flow areas to encourage the ponding of runoff and settling of sediments. It consists of a geotextile fabric secured to wood or steel posts that have been trenched into the ground. It is installed downslope of the disturbed area, installed along slopes, at bases of slopes on a level contour, and around the perimeter of a site as a final barrier to sediment being carried off site. Maximum drainage area and slopes must be considered when determining the appropriateness of silt fence. Silt fence is removed after permanent vegetation is established.

Silt fence must be installed where indicated on the site drawings and as needed throughout the Project site where construction activity is likely to cause sediment-laden runoff to be carried offsite and into downstream surface waters. After construction is completed and the Project site has been permanently stabilized, silt fence must be removed and disposed of at an appropriate offsite disposal facility.

Placing silt fence in a parallel series does not extend the size of the drainage area. Stormwater diversion practices must be used to keep runoff away from disturbed areas and steep slopes where practicable. Such devices, which include swales, dikes or berms, may receive stormwater runoff from areas up to ten (10) acres.

See the silt fence detail located in **Appendix F** (for additional information on proper installation procedures).

Inlet Protection. Storm drain inlet protection devices remove sediment from stormwater before it enters storm sewers and downstream areas. Inlet protection devices may consist of washed gravel or crushed stone, geotextile fabrics, and other materials that are supported around or across storm drain inlets. Inlet protection is installed to capture some sediment and reduce the maintenance of storm sewers and other underground piping systems prior to the site being stabilized. Due to their poor effectiveness, inlet protection is considered a secondary sediment control to be used in conjunction with other more effective controls. Other erosion and sediment control practices must minimize sediment laden water entering active storm drain systems, unless the storm drain system drains to a sediment settling pond. Generally, inlet protection is limited to areas draining less than one (1) acre; areas of one or more acres will require a sediment settling pond.

Filter Sock. Filter socks are sediment-trapping devices using compost inserted into a flexible, permeable tube. Filter socks trap sediment by filtering water passing through the berm and allowing water to pond, creating a settling of solids. Filter socks may be a preferred alternative where equipment may drive near or over sediment barriers, as they are not as prone to complete failure as silt fence if this occurs during construction. Driving over filter socks is not recommended; however, if it should occur, the filter sock must be inspected immediately, repaired, and moved back into place as soon as possible. Typically, filter socks can handle the same water flow or slightly more than silt fence. For most applications, standard silt fence is replaced with twelve (12)-inch diameter filter socks.

Trench Plugs. Trench Plugs are required at each side of streams and wetlands crossings completed by trenching, regardless of trench slope. These requirements supplement DEO’s general construction practice for the placement of plugs in trenches on steep slopes. Trench plugs will also be installed if it is determined that flooding at the low point elevation of a pipeline will adversely affect the adjacent property. Installation will be in accordance with the details depicted in **Detail F-9** and **Table 5** below.

*Table 5: Required Spacing and Materials for Trench Plugs*

<b>Trench Slope (%)</b>	<b>Spacing (ft)</b>	<b>Plug Material</b>
< 5	*	*
5 – 15	500	Sand or Earth** Filled Sacks
15 – 25	300	Sand or Earth** Filled Sacks
25 – 35	200	Sand or Earth** Filled Sacks
35 – 100	100	Sand or Earth** Filled Sacks
> 100	50	Cement Filled Bags (Wetted) or Mortared Stone

- \* Trench Plugs are required at each side of all stream, river or water-body crossings completed by trenching, regardless of trench slope; otherwise not required.
- \*\* Topsoil may not be used to fill sacks.

Modifying Controls. If periodic inspections or other information indicates a control has been used inappropriately or incorrectly, Dominion Energy must replace or modify the control for site conditions.

### **3.7 POST-CONSTRUCTION STORMWATER MANAGEMENT (PCSM)**

The proposed disturbance associated with the Project is temporary; therefore, no permanent stormwater structures will be required. The Project area will be restored to original contours and re-vegetated. No impervious areas will be created for this Project.

### **3.8 OTHER CONTROLS**

In some instances, a non-sediment pollutant source may become present on the Project site and pollution controls may be required.

#### **Non-Sediment Pollutant Controls**

Handling of Toxic or Hazardous Materials. All construction personnel, including subcontractors who may use or handle hazardous or toxic materials, must be made aware of the general guidelines regarding management and disposal of toxic or hazardous construction wastes. This can be accomplished by training for construction personnel by the Contractor or by Dominion Energy.

Waste Disposal. Containers (e.g., dumpsters, drums) must be available for the proper collection of all waste material including construction debris, sanitary garbage, petroleum products, and any hazardous materials to be used on-site. Containers must be covered, as required, and not leaking. All waste material must be disposed of at facilities approved by the Ohio EPA for that material. Ensure storage time frames are not exceeded.

Clean Hard Fill. No Construction related waste materials are to be buried on-site. By exception, clean fill (clean bricks, hardened concrete, and soil) may be utilized in a way which does not encroach upon natural wetlands, streams, or floodplains or result in the contamination of waters.

Construction and Demolition Debris (C&DD). C&DD waste will be disposed of in an Ohio EPA permitted C&DD landfill as required by ORC 3714 and approved by Dominion Energy.

Construction Chemical Compounds. Storing, mixing, pumping, transferring or other handling of construction chemicals such as fertilizer, lime, asphalt, concrete drying compounds, and all other potentially hazardous materials must be done in an area away from any waterbody, ditch, or storm drain.

Equipment Fueling and Maintenance. Oil changing, equipment refueling, maintenance on hydraulic systems, etc., must be performed away from waterbodies, ditches, or storm drains, and

in an area designated for that purpose. The designated area must be equipped for recycling oil and catching spills. Secondary containment must be provided for all fuel and oil storage tanks. These areas must be inspected every seven (7) days and within 24 hours of a one-half (0.5)-inch or greater rain event to ensure there are no exposed materials which would contaminate stormwater. Site operators must be aware that Spill Prevention Control and Countermeasures (SPCC) requirements may apply. An SPCC plan is required for sites with accumulative aboveground storage of 1,320 gallons or more, or 42,000 gallons of underground storage.

No detergent may be used to wash vehicles. Wash waters will be treated in a sediment basin or alternative control which provides equivalent treatment prior to discharge.

Concrete Wash Water and Wash Outs. Concrete wash water must not be allowed to flow to streams, ditches, storm drains, or any other water conveyance. A lined sump or pit with no potential for discharge must be constructed if needed to contain concrete wash water. Field tile (agricultural drain tiles) or other subsurface drainage structures within ten (10) feet of the concrete sump or wash pit must be cut and plugged. Concrete wash water is wastewater and thus is not permitted to be discharged under the provisions of Ohio EPA's Construction General Permit which only allows the discharge of stormwater. Concrete washout details are located in **Appendix J**. The location for concrete washout will be determined in the field as necessary.

Spill Reporting Requirements. In the event of a spill of a regulated or hazardous material, immediately contact the Dominion Energy ECC assigned to the site or Project. The Dominion Energy ECC (if Dominion Energy ECC not available, other Dominion Energy Environmental staff) will coordinate spill reporting to the appropriate agencies. Spills on pavement must be absorbed with sawdust, kitty litter or other absorbent material. Spills to land require excavation of the contaminated material. Wastes generated from spill cleanup must be disposed of in accordance with applicable Federal, State, and Local waste regulations. Hazardous or industrial wastes including, but not limited to, most solvents, gasoline, oil-based paints, oil, grease, battery acid, muriatic acid, and cement curing compounds require special handling<sup>1</sup>. Spills must be reported to Ohio EPA (1-800-282-9378). Spills of 25 gallons or more of petroleum products must be reported to Ohio EPA (1-800-282-9378), the local fire department, and the Local Emergency Planning Committee within thirty (30) minutes of the discovery of the release. All spills (no matter how small), which result in contact with waters of the state, must be reported to Ohio EPA's Hotline. Spills of hazardous substances, extremely hazardous substances, petroleum, and objectionable substances that are of a quantity, type, duration, and in a location as to damage the waters of the state must be immediately reported to the Ohio EPA's Regional Environmental Coordinator.

---

<sup>1</sup> The Federal Resource Conservation and Recovery Act (RCRA) requires that all wastes generated by industrial activity, including construction activities, be evaluated to determine if the waste is hazardous, non-hazardous or special wastes. Hazardous waste and special wastes have specific handling and disposal requirements which must be met to comply with RCRA. Additional information regarding the waste evaluation process and the proper handling and disposal requirements for wastes can be found in the following Dominion Guidance Documents: "Hazardous Waste Guidance", "Hazardous Waste Guidance Labeling", "Hazardous Waste Guidance Labeling - Appendix A", "Nonhazardous Waste Management", "Universal Waste Management", "Universal Waste Guidance - Appendix A - Labeling Matrix", and "Used Oil and Oil Filter Management". Consult with the DES ECC assigned to the site or project for advice.



Contaminated Soils. If substances such as oil, diesel fuel, hydraulic fluid, antifreeze, etc. are spilled, leaked, or released onto the soil, the soil must be dug up and disposed of at a licensed sanitary landfill or other approved petroleum contaminated soil remediation facility (not a construction/demolition debris landfill) which has been approved by Dominion Energy.

Open Burning. Waste disposal by open burning is prohibited by Dominion Energy.

Dust Controls/Suppressants. Dust control is required to prevent nuisance conditions. Dust controls must be used in accordance with the manufacturer's specifications and not be applied in a manner, which would result in a discharge to waters of the state. Isolation distances from bridges, catch basins, and other drainage ways must be observed. Application (excluding water) may not occur when precipitation is imminent as noted in the short term forecast. Used oil may not be applied for dust control. Watering must be done at a rate that prevents dust but does not cause soil erosion. Chemical stabilizers and adhesives must not be used, unless written permission is received from Ohio EPA.

Air Permitting Requirements. All contractors and subcontractors must be made aware that certain activities associated with construction will require air permits. Activities including, but not limited to, mobile concrete batch plants, mobile asphalt plants, concrete crushers, generators, etc., will require specific Ohio EPA Air Permits for installation and operation. Dominion Energy must seek authorization from the corresponding district of Ohio EPA for these activities. Notification for Restoration and Demolition must be submitted to Ohio EPA for all commercial sites to determine if asbestos abatement actions are required.

Process Wastewater/Leachate Management. All contractors must be made aware that Ohio EPA's Construction General Permit only allows the discharge of stormwater. Other waste discharges including, but not limited to, vehicle and/or equipment washing, leachate associated with on-site waste disposal, concrete wash outs, etc. are a process wastewater. These types of wastewaters are not authorized for discharge under the General Stormwater Permit associated with Construction Activities. All process wastewaters must be collected and properly disposed at an Dominion Energy approved disposal facility. In the event there are leachate outbreaks (water that has passed through contaminated material and has acquired elevated concentrations of the contaminated material) associated with onsite disposal, measures must be taken to isolate this discharge for collection and proper disposal at an Dominion Energy approved disposal facility. Investigative measures and corrective actions must be implemented to identify and eliminate the source of all leachate outbreaks.

Permit to Install (PTI) Requirements. All contractors and subcontractors must be made aware that a PTI must be submitted and approved by Ohio EPA prior to the construction of all centralized sanitary systems, including sewer extensions, and sewerage systems (except those serving one (1), two (2), and three (3) family dwellings) and potable water lines. The issuance of an Ohio EPA Construction General Stormwater Permit does not authorize the installation of any sewerage system where Ohio EPA has not approved a PTI. If necessary, Dominion Energy will acquire the PTI or Dominion Energy will require the contractor to acquire the PTI.

Compliance with Other Requirements. This plan is consistent with State and/or local waste disposal, sanitary sewer or septic system regulations including provisions prohibiting waste disposal by open burning. Contaminated soils are not expected to be encountered on this Project. If they are encountered within the limits of construction, they will be managed and disposed of properly by trained personnel.

Trench and Groundwater Control. There must be no turbid discharges to surface waters of the State resulting from dewatering activities. If trench or groundwater contains sediment, it must pass through a sediment settling pond or other equally effective sediment control device, prior to being discharged from the construction site. Alternatively, sediment may be removed by settling in place or by dewatering into a sump pit, filter bag, or comparable practice. Groundwater dewatering which does not contain sediment or other pollutants is not required to be treated prior to discharge. However, care must be taken when discharging groundwater to ensure that it does not become pollutant laden by traversing over disturbed soils or other pollutant sources. Discharge of contaminated groundwater is not authorized.

Contaminated Sediment. Where construction activities are to occur on sites with historical contamination, operators must be aware that concentrations of materials that meet other criteria (is not considered a Hazardous Waste, meeting VAP standards, etc.) may still result in stormwater discharges in excess of Ohio Water Quality Standards. Such discharges are not authorized and may require coverage under a separate individual or general remediation permit. Contaminated soil stockpiles shall be protected from discharges by covering the contaminated soil with a tarp or other such material which will prohibit water from coming in contact with the soils. Contaminated soils can also be removed from the site and disposed of at a Dominion Energy approved facility.

### **3.9 MAINTENANCE**

All temporary and permanent control measures must be maintained and repaired as needed to ensure continued performance of their intended function. All sediment control measures must be maintained in a functional condition until all up slope areas are permanently stabilized. The following maintenance procedures will be conducted to ensure the continued performance of control practices.

- Qualified personnel must inspect all BMPs at least once every seven (7) days and after any storm event greater than one-half inch of rain per 24-hour period by the end of the next calendar day, excluding weekends and holidays, unless work is scheduled. Rainfall amounts will be determined by Dominion Energy personnel or a designated representative using National Weather Service or other acceptable resources such as an on-site rain gauge, and determine if the SWP3 has been properly implemented.
- Maintenance or repair of BMPs must be completed by the designated contractor within three (3) days of the date of the inspection that revealed a deficiency. For sediment ponds, repair or maintenance is required within ten (10) days of the date of the inspection.
- Off-site vehicle tracking of sediments and dust generation must be minimized. Temporary construction entrances must be provided where applicable to help reduce vehicle tracking

of sediment. Any paved roads adjacent to the site entrance must be swept daily to remove excess mud, dirt, or rock tracked from the site, as necessary.

### 3.10 INSPECTIONS

The following inspection practices must be followed once site activities have commenced and erosion and sediment control measures have been installed.

- All onsite controls must be inspected by Dominion Energy personnel or a designated representative at least once every seven (7) calendar days and after any storm event greater than one-half inch of rain per 24-hour period by the end of the next calendar day, excluding weekends and holidays, unless work is scheduled.
- Inspection frequency may be reduced to at least once every month if the entire site is temporarily stabilized or runoff is unlikely due to weather conditions (e.g., site is covered with snow, ice, or the ground is frozen). A waiver of inspection requirements is available from Ohio EPA until one (1) month before thawing conditions are expected to result in a discharge if all of the following conditions are met: the Project is located in an area where frozen conditions are anticipated to continue for extended periods of time (i.e., more than one (1) month); land disturbance activities have been suspended; and the beginning and ending dates of the waiver period are documented in the SWP3. Dominion Energy will obtain the waiver at the request of the contractor.
- Once a definable area has reached final stabilization as defined in Section 3.2 Erosion Control Practices, the area must be marked on the SWP3 and no further inspection requirements apply to that portion of the site.
- A Dominion Energy or a designated representative “qualified inspection personnel” must conduct inspections to ensure that the control practices are functional and to evaluate whether the SWP3 is adequate and properly implemented in accordance with the schedule or whether additional control measures are required.
- Following inspection, a checklist must be completed and signed by the qualified inspection personnel representative. The inspection form and checklist is provided in **Appendix K**. The record and certification must be signed in accordance with Ohio Permit OHC000006.
- Inspection reports must be maintained for three (3) years following the submittal of a Notice of Termination.
- For BMPS that require repair or maintenance, BMPs must be repaired or maintained within three (3) days of the inspection; sediment settling ponds must be repaired or maintained within ten (10) days of the inspection.
- For BMPs that are not effective and that another, more appropriate BMP is required, the SWP3 must be amended and the more appropriate BMP must be installed within ten (10) days of the inspection.

- For BMPs depicted on the SWP3 that have not been actually installed onsite, the control practice must be implemented within ten (10) days from the inspection.



#### **4.0 APPROVED STATE OR LOCAL PLANS**

This SWP3 must comply, unless exempt, with the lawful requirements of municipalities, counties, and other local agencies regarding discharges of stormwater from construction activities. All erosion and sediment control plans and stormwater management plans approved by local officials must be retained.

## **5.0 EXCEPTIONS**

If specific site conditions prohibit the implementation of any of the erosion and sediment control practices contained in this plan or site specific conditions are such that implementation of any erosion and sediment control practices contained in this plan will result in no environmental benefit, then Dominion Energy must provide justification for rejecting each practice based on site conditions. Dominion Energy may request approval from Ohio EPA and any other applicable regulatory authority to use alternative methods if Dominion Energy can demonstrate that the alternative methods are sufficient to protect the overall integrity of receiving streams and the watershed.

## **6.0 NOTICE OF TERMINATION REQUIREMENTS**

Once a site reaches final stabilization and construction activities have ceased, NPDES permit coverage is terminated by filing a notice of termination (NOT). The NOT must be filed within 45 days of reaching final stabilization. The terms and conditions of this permit must remain in effect until a signed NOT form is submitted. NOT forms must be submitted in accordance with Ohio Permit OHC000006.

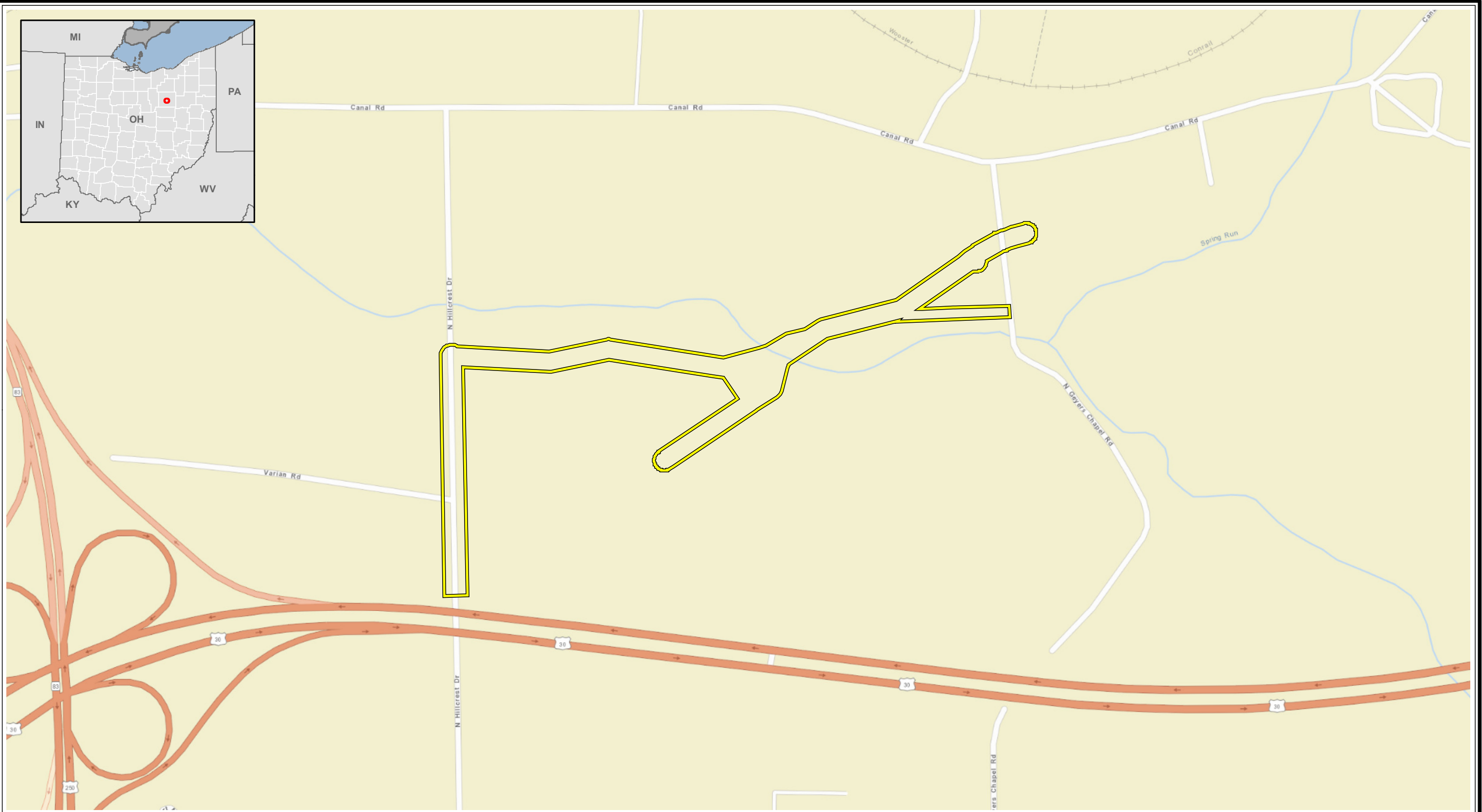
Similarly, a notice of completion must be provided to any municipalities, counties, and other local agencies that require such notice.

---

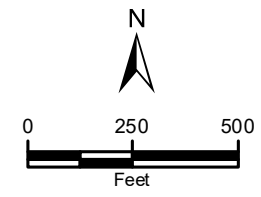
## **APPENDIX A**

### **Site Location Maps**





 Project Study Area



Base Layer: ESRI Street Map 2019


**Appendix A - Figure 1  
Site Location**

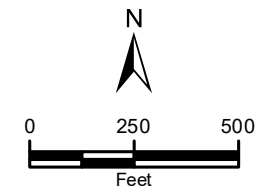
PIR 2788 - Apple Creek  
Dominion Energy Ohio  
Wayne County, Ohio  
Date: 1/17/2024







 Project Study Area



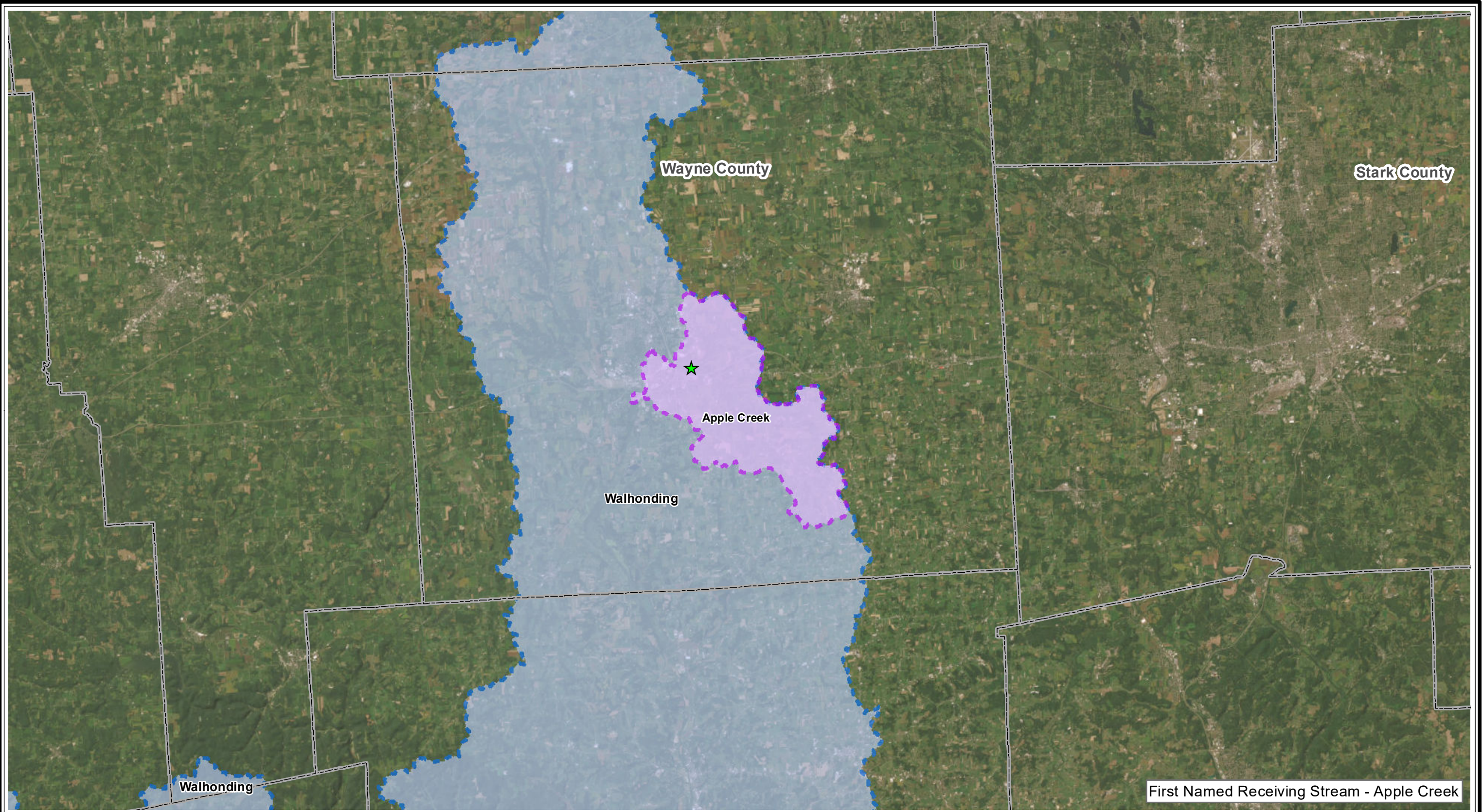
Base Layer: US TopoMaps, 1998

**Appendix A - Figure 2**  
**USGS Topographic - Wooster Quadrangle**

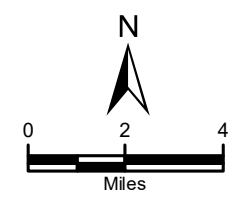
PIR 2788 - Apple Creek  
Dominion Energy Ohio  
Wayne County, Ohio  
Date: 1/17/2024







- ★ Project Study Area - Approx. Location
- HUC 12: Apple Creek
- HUC 8: Walhonding
- County Boundaries



Sources: USGS NAIP Aerial

First Named Receiving Stream - Apple Creek

**Appendix A - Figure 3  
Watershed Location Map**

PIR 2788 - Apple Creek  
Dominion Energy Ohio  
Wayne County, Ohio  
Date: 1/17/2024





---

## **APPENDIX B**

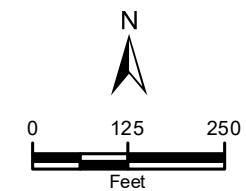
### **Soil Map and Table**



Symbol	Description	Hydric Rating	Acreage*
BrF	Berks silt loam, 25 to 70 percent slopes	Nonhydric	1.10
BtB	Bogart loam, 2 to 6 percent slopes	Nonhydric	0.76
CdB	Canfield silt loam, 2 to 6 percent slopes	Nonhydric	2.11
FcB	Fitchville silt loam, 2 to 6 percent slopes	Predominantly Nonhydric	0.70
Le	Lobdell silt loam, occasionally flooded	Predominantly Nonhydric	0.18
Tg	Tioga silt loam, occasionally flooded	Nonhydric	6.69
WuC	Wooster-Riddles silt loams, 6 to 12 percent slopes	Nonhydric	1.41
<b>*Note: Acreage is rounded to the nearest 100th acre.</b>		<b>Total</b>	<b>12.95</b>



- Project Study Area
- NRCS Soils
- NRCS Soils - Hydric Rating
- Predominantly Nonhydric
- Nonhydric



Base Layer: OSIP Aerial, 2016

**Appendix B - Figure 1  
NRCS Soil Survey Units**

PIR 2788 - Apple Creek  
Dominion Energy Ohio  
Wayne County, Ohio

Date: 1/17/2024





**Appendix B - Soil Types and Descriptions**

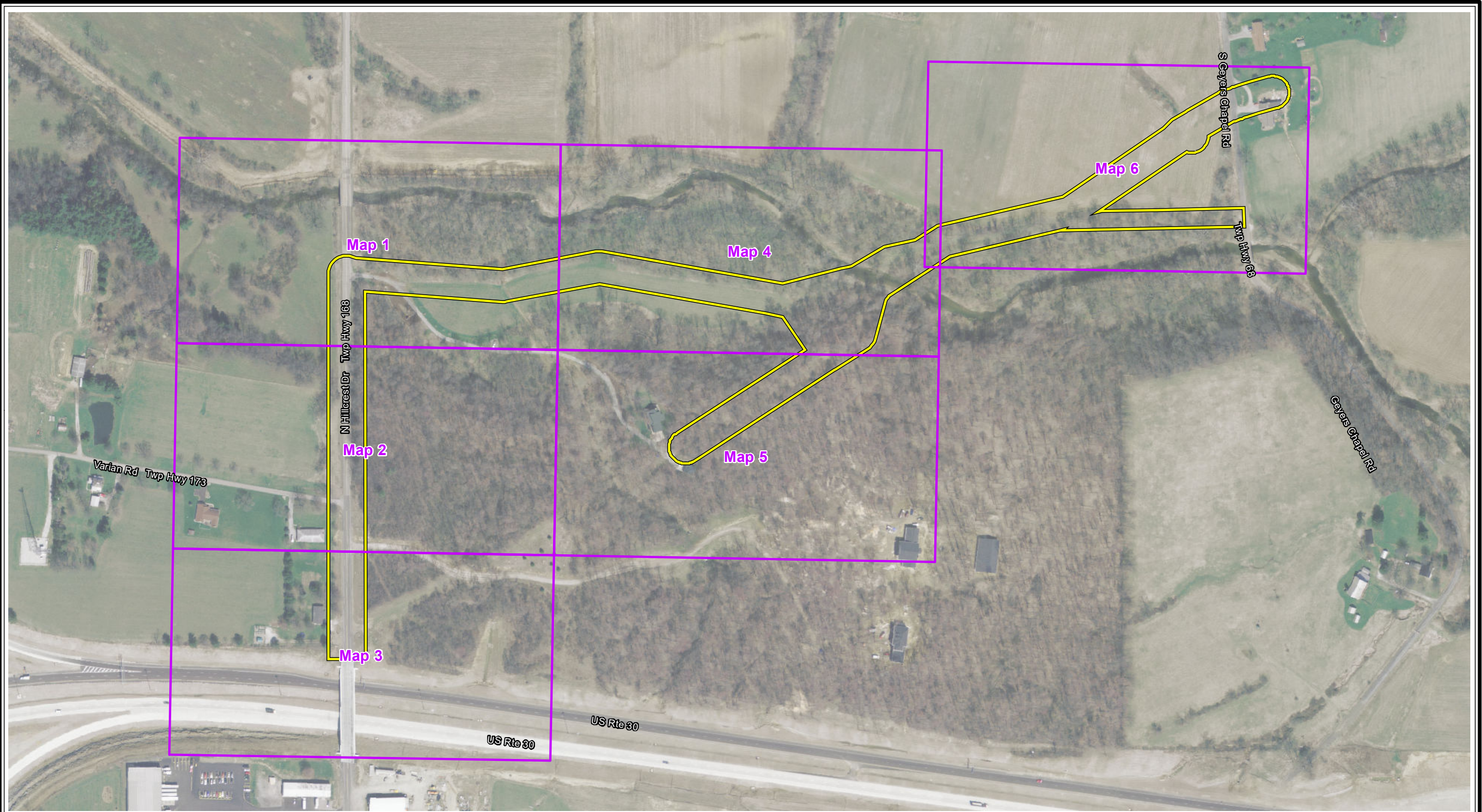
<b>Soil Type</b>	<b>Map Symbol</b>	<b>Slope</b>	<b>Material</b>	<b>Drainage Class</b>	<b>Location</b>	<b>Depth to Water Table (cm)</b>	<b>Depth to Restrictive Feature (cm)</b>	<b>K Factor, Whole Soil (Erodibility)</b>
Tioga silt loam, occasionally flooded	Tg	1%	Alluvium	Well drained	Floodplains	137	>200	0.32
Canfield silt loam, 2 to 6 percent slopes	CdB	4%	Till	Moderately well drained	Till plains	38	66	0.37
Wooster-Riddles silt loams, 6 to 12 percent slopes	WuC	9%	Till	Well drained	Ridges, hills, terraces	153	69	0.43
Berks silt loam, 25 to 70 percent slopes	BrF	48%	Residuum weathered from sandstone and shale and/or residuum weathered from siltstone	Well drained	Valleys, floodplains	>200	71	0.37
Bogart loam, 2 to 6 percent slopes	BtB	4%	Stratified outwash	Moderately well drained	Terraces, lake plains	84	>200	0.28
Fitchville silt loam, 2 to 6 percent slopes	FcB	4%	Glaciolacustrine deposits	Somewhat poorly drained	Terraces	23	>200	0.37
Lobdell silt loam, occasionally flooded	Le	1%	Alluvium	Moderately well drained	Floodplains	84	>200	0.37



---

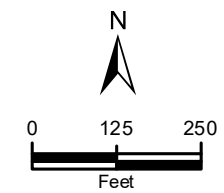
## **APPENDIX C**

# **Detailed Erosion and Sediment Control Location Drawings**





 Project Study Area  
 Map Extent



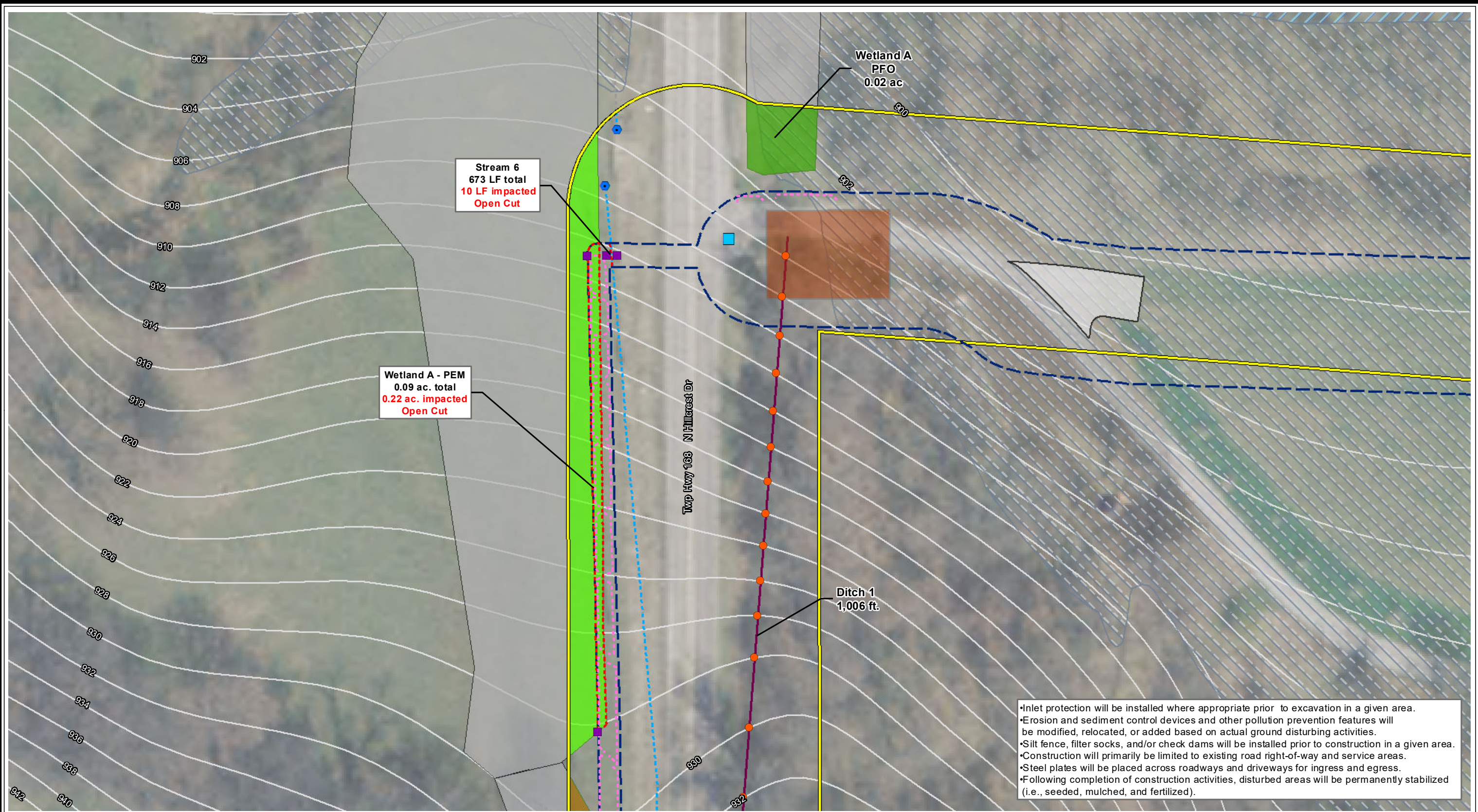
Base Layer: OSIP 2016

**Appendix C - Figure 1**  
**Erosion and Sediment Control Map Book**

PIR 2788 - Apple Creek  
 Dominion Energy Ohio  
 Wayne County, Ohio  
 Date: 1/17/2024

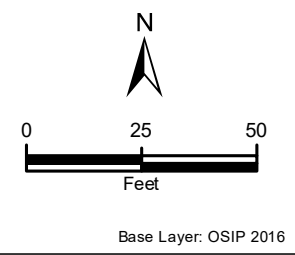
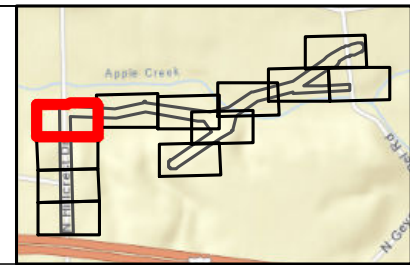






- Inlet protection will be installed where appropriate prior to excavation in a given area.
- Erosion and sediment control devices and other pollution prevention features will be modified, relocated, or added based on actual ground disturbing activities.
- Silt fence, filter socks, and/or check dams will be installed prior to construction in a given area.
- Construction will primarily be limited to existing road right-of-way and service areas.
- Steel plates will be placed across roadways and driveways for ingress and egress.
- Following completion of construction activities, disturbed areas will be permanently stabilized (i.e., seeded, mulched, and fertilized).

Project Study Area	Wetland Impact	Off-site Intermittent Stream	Off-Site Wetland
Work Corridor	Stormwater Inlet	On-site Ephemeral Stream	Flood Zones (FEMA)
Construction Entrance	Culvert	Off-site Ephemeral Stream	1% Annual Chance Flood Hazard
Gravel Access Road	Potential Roost Tree	Delineated Ditch	Regulatory Floodway
Trench Plug	Delineated Stream	On-site Emergent Wetland	2-Foot Contour
Check Dam	On-site Perennial Stream	On-site Forested Wetland	
Filter Fence	Off-site Perennial Stream	On-site Shrub Scrub Wetland	
Stream Impact	On-site Intermittent Stream		

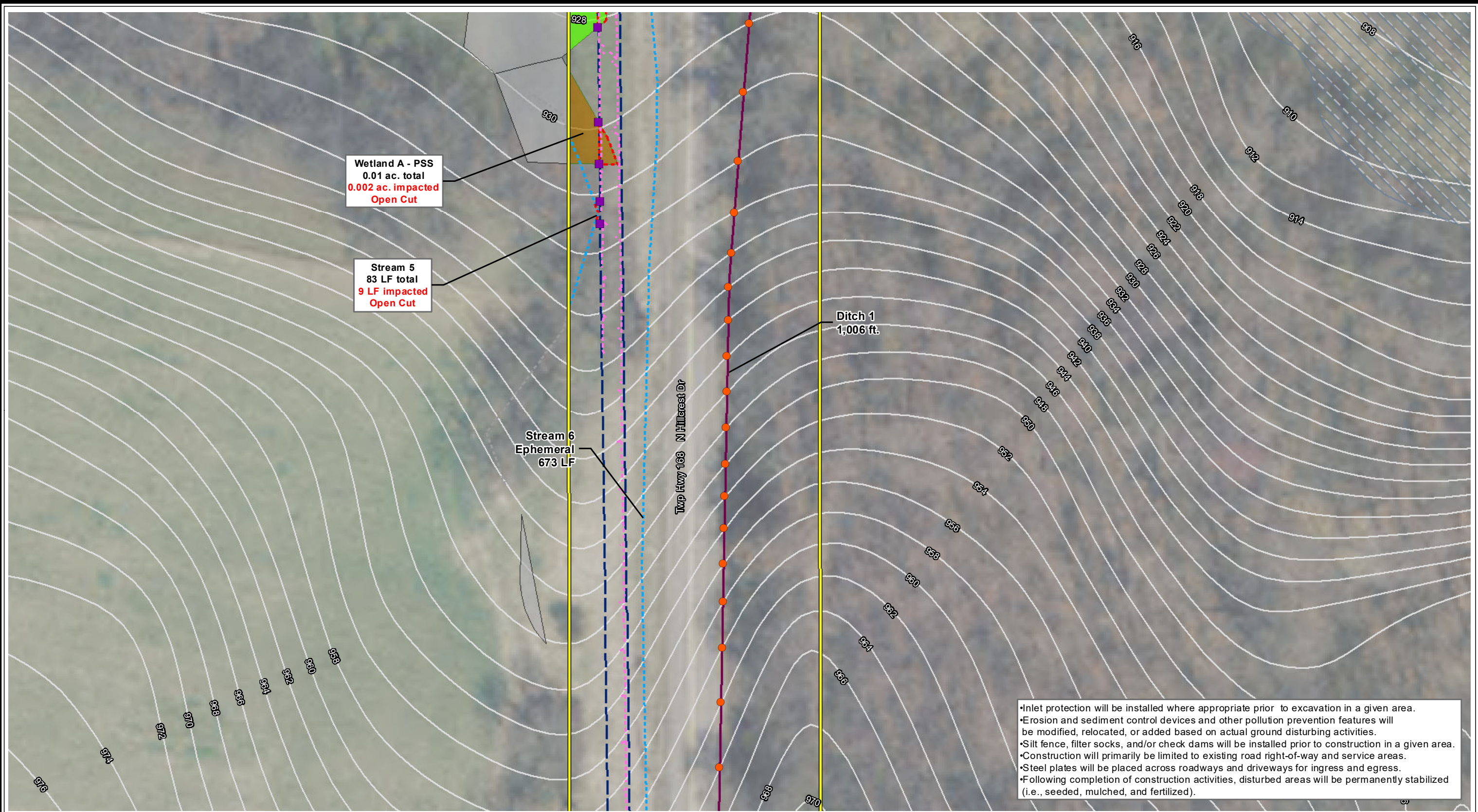


**Appendix C - Figure 1**  
**Erosion and Sediment Control Map 1 of 12**

PIR 2788 - Apple Creek  
 Dominion Energy Ohio  
 Wayne County, Ohio  
 Date: 2/20/2024







Wetland A - PSS  
0.01 ac. total  
0.002 ac. impacted  
Open Cut

Stream 5  
83 LF total  
9 LF impacted  
Open Cut

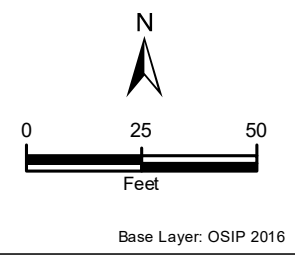
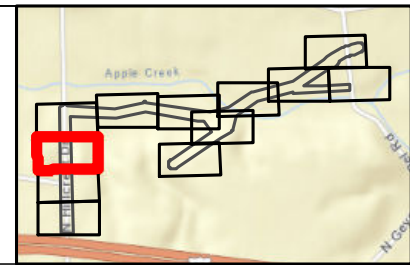
Stream 6  
Ephemeral  
673 LF

Ditch 1  
1,006 ft.

Twp Hwy 168 N Hillcrest Dr

- Inlet protection will be installed where appropriate prior to excavation in a given area.
- Erosion and sediment control devices and other pollution prevention features will be modified, relocated, or added based on actual ground disturbing activities.
- Silt fence, filter socks, and/or check dams will be installed prior to construction in a given area.
- Construction will primarily be limited to existing road right-of-way and service areas.
- Steel plates will be placed across roadways and driveways for ingress and egress.
- Following completion of construction activities, disturbed areas will be permanently stabilized (i.e., seeded, mulched, and fertilized).

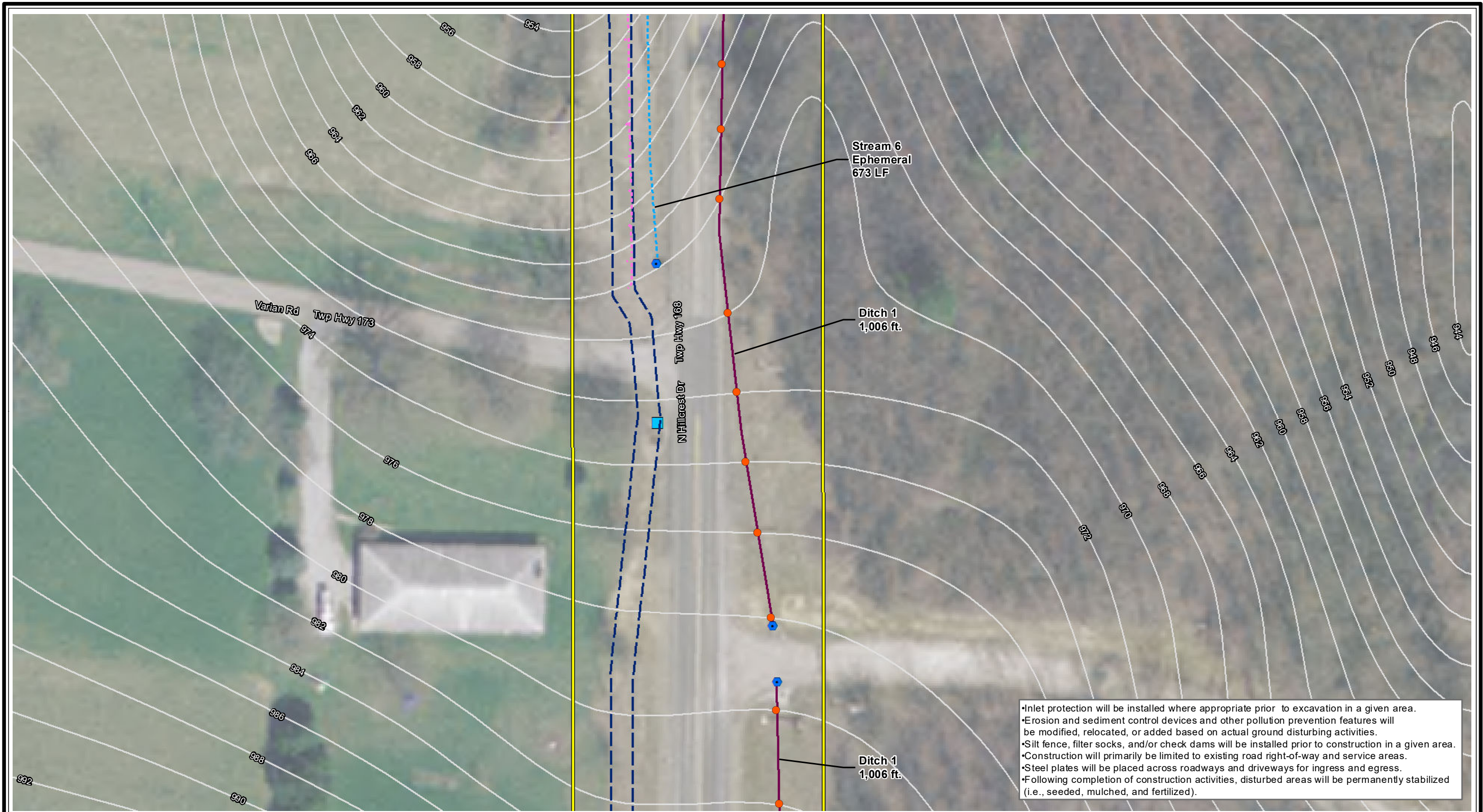
Project Study Area	Wetland Impact	Off-site Intermittent Stream	Off-Site Wetland
Work Corridor	Stormwater Inlet	On-site Ephemeral Stream	Flood Zones (FEMA)
Construction Entrance	Culvert	Off-site Ephemeral Stream	1% Annual Chance Flood Hazard
Gravel Access Road	Potential Roost Tree	Delineated Ditch	Regulatory Floodway
Trench Plug	Delineated Stream	On-site Perennial Stream	2-Foot Contour
Check Dam	On-site Perennial Stream	On-site Emergent Wetland	
Filter Fence	Off-site Perennial Stream	On-site Forested Wetland	
Stream Impact	On-site Intermittent Stream	On-site Shrub Scrub Wetland	



**Appendix C - Figure 1**  
**Erosion and Sediment Control Map 2 of 12**

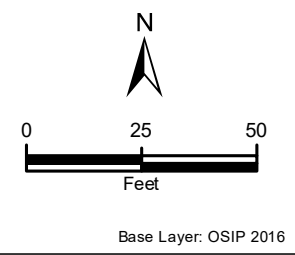
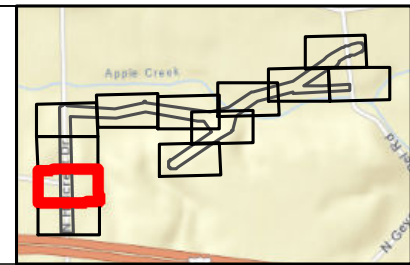
PIR 2788 - Apple Creek  
 Dominion Energy Ohio  
 Wayne County, Ohio  
 Date: 2/20/2024






- Inlet protection will be installed where appropriate prior to excavation in a given area.
- Erosion and sediment control devices and other pollution prevention features will be modified, relocated, or added based on actual ground disturbing activities.
- Silt fence, filter socks, and/or check dams will be installed prior to construction in a given area.
- Construction will primarily be limited to existing road right-of-way and service areas.
- Steel plates will be placed across roadways and driveways for ingress and egress.
- Following completion of construction activities, disturbed areas will be permanently stabilized (i.e., seeded, mulched, and fertilized).

Project Study Area	Wetland Impact	Off-site Intermittent Stream	Off-Site Wetland
Work Corridor	Stormwater Inlet	On-site Ephemeral Stream	Flood Zones (FEMA)
Construction Entrance	Culvert	Off-site Ephemeral Stream	1% Annual Chance Flood Hazard
Gravel Access Road	Potential Root Tree	Delineated Ditch	Regulatory Floodway
Trench Plug	<b>Delineated Stream</b>	On-site Emergent Wetland	2-Foot Contour
Check Dam	On-site Perennial Stream	On-site Forested Wetland	
Filter Fence	Off-site Perennial Stream	On-site Shrub Scrub Wetland	
Stream Impact	On-site Intermittent Stream		

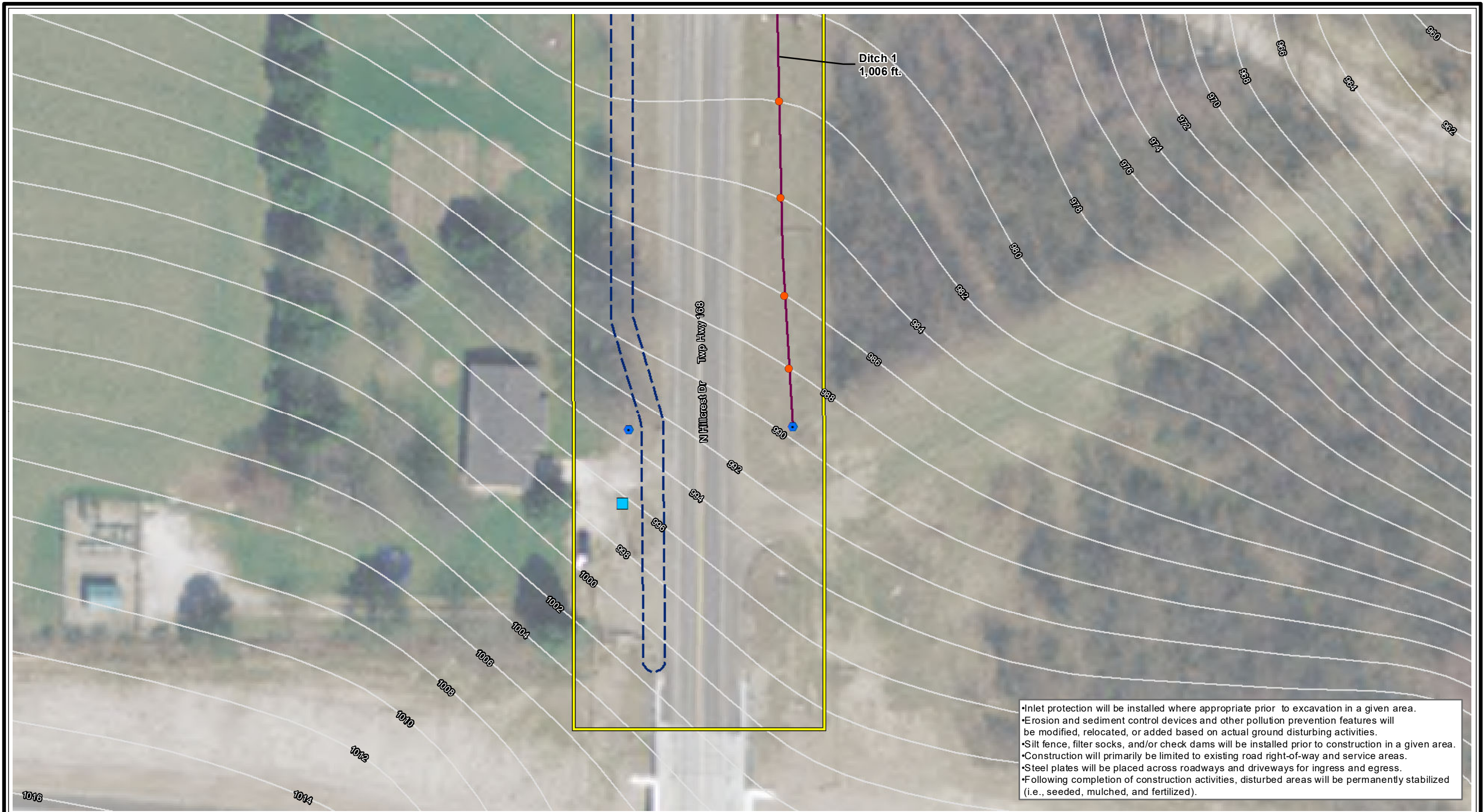


**Appendix C - Figure 1**  
**Erosion and Sediment Control Map 3 of 12**

PIR 2788 - Apple Creek  
 Dominion Energy Ohio  
 Wayne County, Ohio  
 Date: 2/20/2024

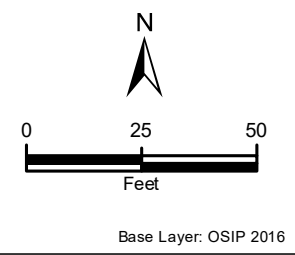
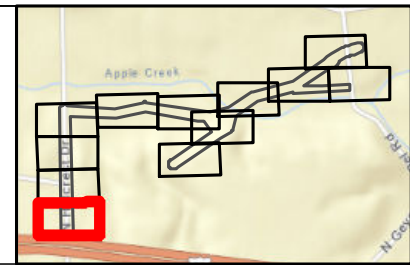






- Inlet protection will be installed where appropriate prior to excavation in a given area.
- Erosion and sediment control devices and other pollution prevention features will be modified, relocated, or added based on actual ground disturbing activities.
- Silt fence, filter socks, and/or check dams will be installed prior to construction in a given area.
- Construction will primarily be limited to existing road right-of-way and service areas.
- Steel plates will be placed across roadways and driveways for ingress and egress.
- Following completion of construction activities, disturbed areas will be permanently stabilized (i.e., seeded, mulched, and fertilized).

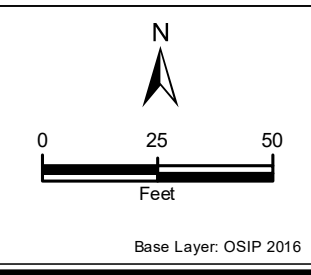
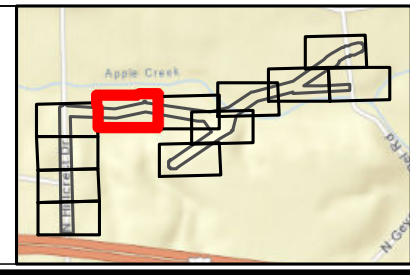
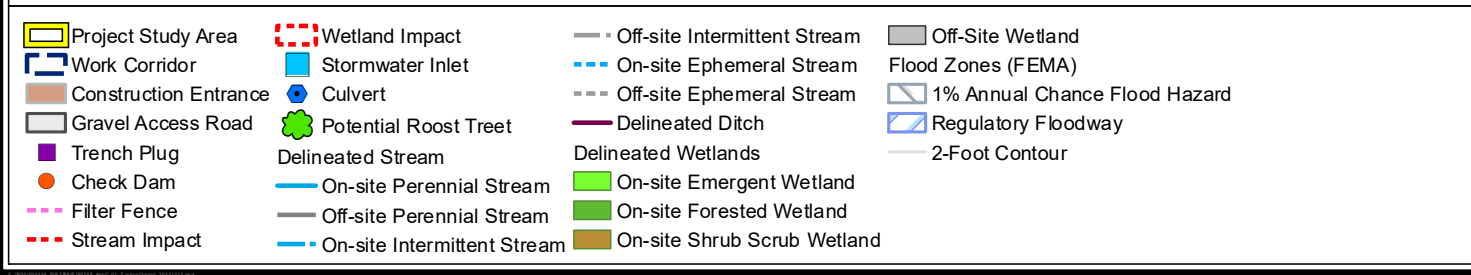
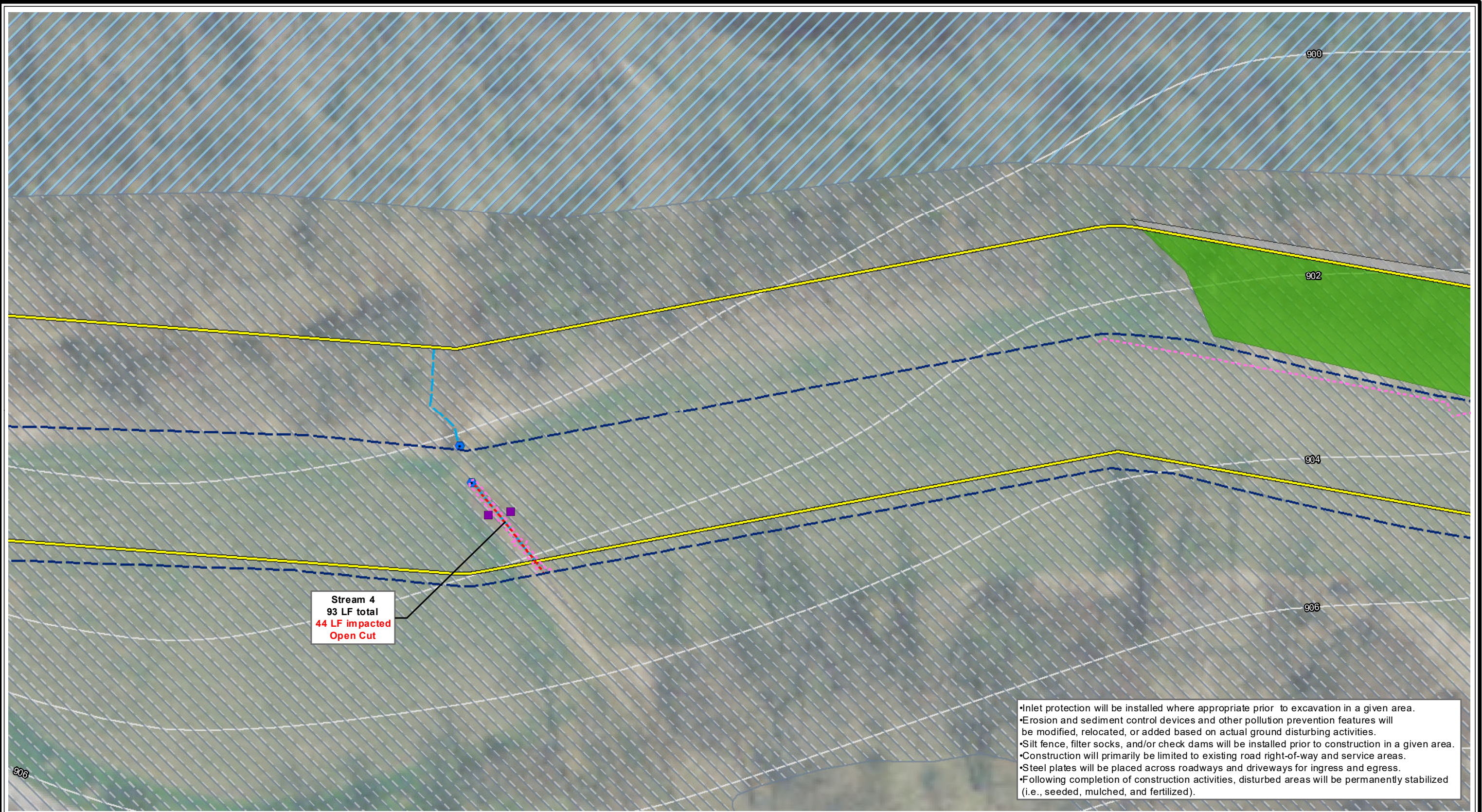
Project Study Area	Wetland Impact	Off-site Intermittent Stream	Off-Site Wetland
Work Corridor	Stormwater Inlet	On-site Ephemeral Stream	Flood Zones (FEMA)
Construction Entrance	Culvert	Off-site Ephemeral Stream	1% Annual Chance Flood Hazard
Gravel Access Road	Potential Root Tree	Delineated Ditch	Regulatory Floodway
Trench Plug	Delineated Stream	Delineated Wetlands	2-Foot Contour
Check Dam	On-site Perennial Stream	On-site Emergent Wetland	
Filter Fence	Off-site Perennial Stream	On-site Forested Wetland	
Stream Impact	On-site Intermittent Stream	On-site Shrub Scrub Wetland	



**Appendix C - Figure 1**  
**Erosion and Sediment Control Map 4 of 12**

PIR 2788 - Apple Creek  
 Dominion Energy Ohio  
 Wayne County, Ohio  
 Date: 2/20/2024

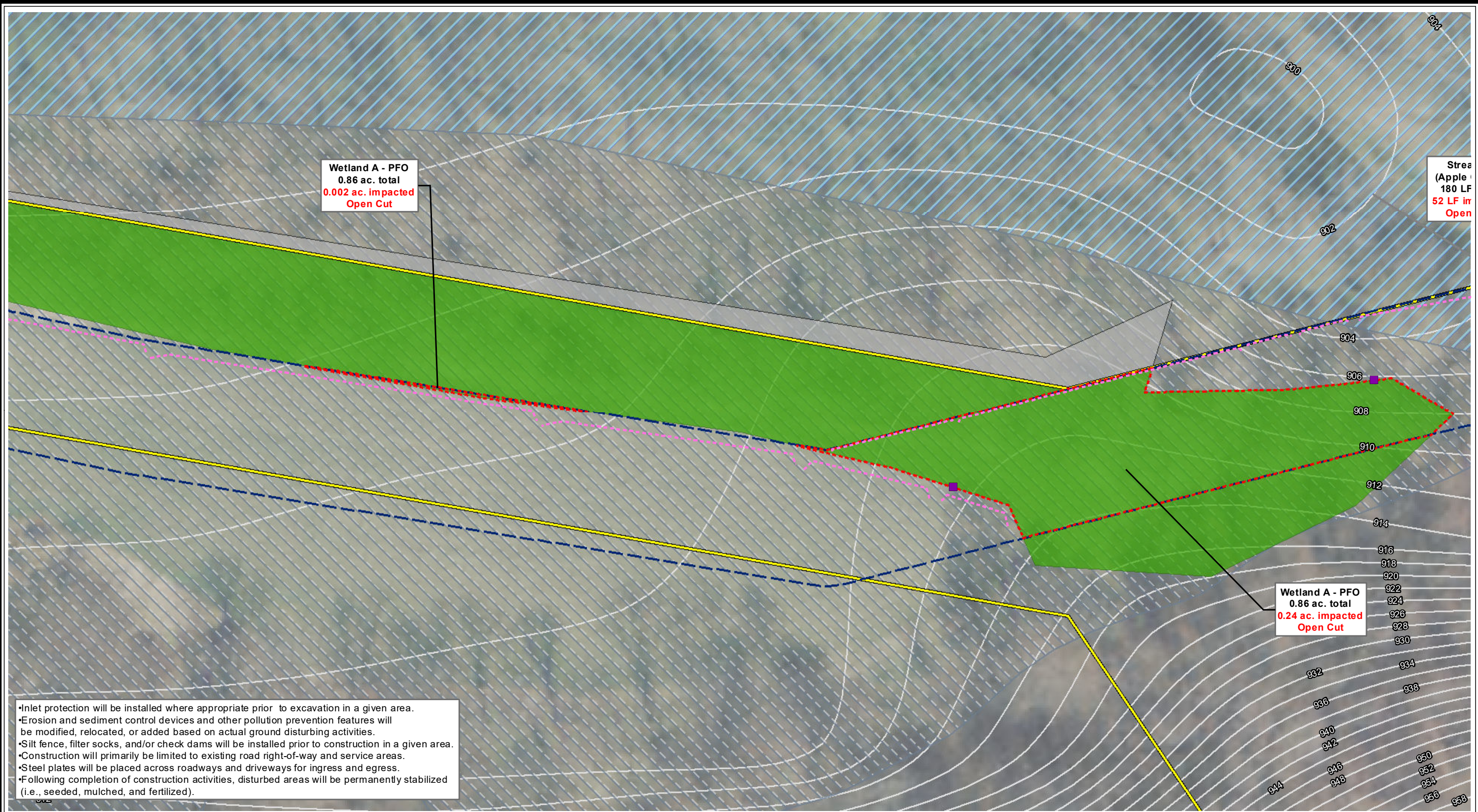




**Appendix C - Figure 1**  
**Erosion and Sediment Control Map 5 of 12**

PIR 2788 - Apple Creek  
Dominion Energy Ohio  
Wayne County, Ohio  
Date: 2/20/2024





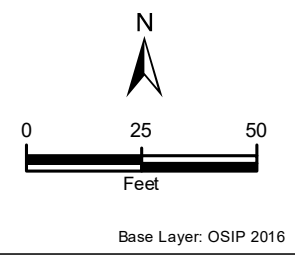
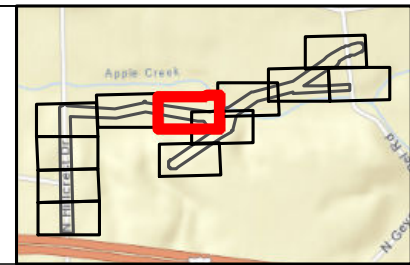
Wetland A - PFO  
0.86 ac. total  
0.002 ac. impacted  
Open Cut

Stream  
(Apple Creek)  
180 LF impacted  
52 LF impacted  
Open

Wetland A - PFO  
0.86 ac. total  
0.24 ac. impacted  
Open Cut

- Inlet protection will be installed where appropriate prior to excavation in a given area.
- Erosion and sediment control devices and other pollution prevention features will be modified, relocated, or added based on actual ground disturbing activities.
- Silt fence, filter socks, and/or check dams will be installed prior to construction in a given area.
- Construction will primarily be limited to existing road right-of-way and service areas.
- Steel plates will be placed across roadways and driveways for ingress and egress.
- Following completion of construction activities, disturbed areas will be permanently stabilized (i.e., seeded, mulched, and fertilized).

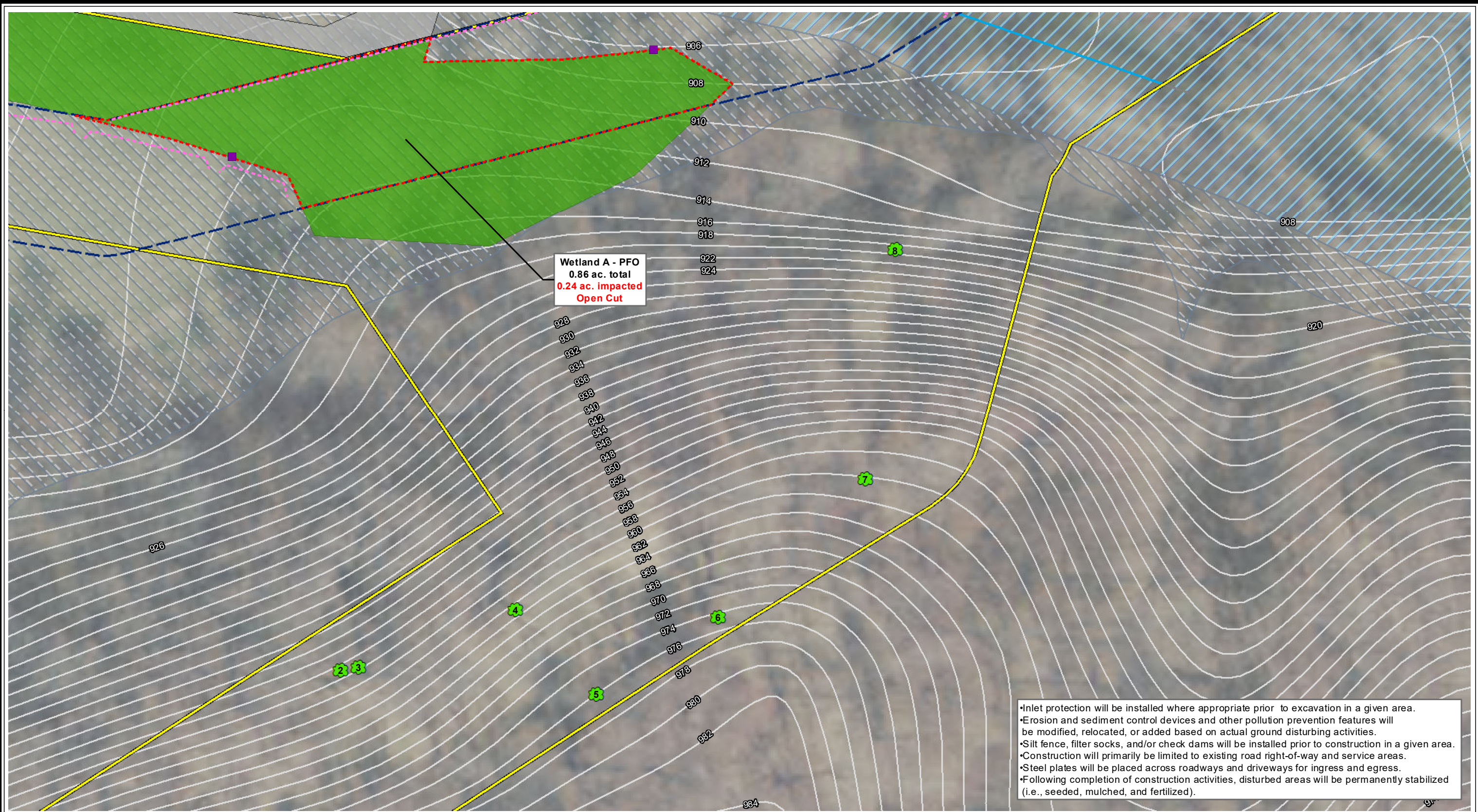
Project Study Area	Wetland Impact	Off-site Intermittent Stream	Off-Site Wetland
Work Corridor	Stormwater Inlet	On-site Ephemeral Stream	Flood Zones (FEMA)
Construction Entrance	Culvert	Off-site Ephemeral Stream	1% Annual Chance Flood Hazard
Gravel Access Road	Potential Root Tree	Delineated Ditch	Regulatory Floodway
Trench Plug	Delineated Stream	Delineated Wetlands	2-Foot Contour
Check Dam	On-site Perennial Stream	On-site Emergent Wetland	
Filter Fence	Off-site Perennial Stream	On-site Forested Wetland	
Stream Impact	On-site Intermittent Stream	On-site Shrub Scrub Wetland	



**Appendix C - Figure 1**  
**Erosion and Sediment Control Map 6 of 12**

PIR 2788 - Apple Creek  
 Dominion Energy Ohio  
 Wayne County, Ohio  
 Date: 2/20/2024

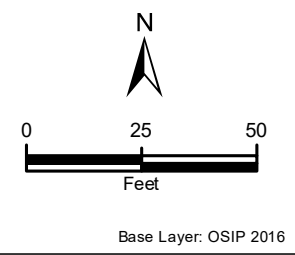
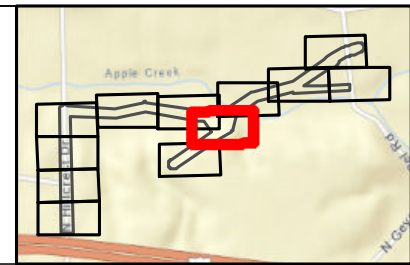




Wetland A - PFO  
 0.86 ac. total  
 0.24 ac. impacted  
 Open Cut

- Inlet protection will be installed where appropriate prior to excavation in a given area.
- Erosion and sediment control devices and other pollution prevention features will be modified, relocated, or added based on actual ground disturbing activities.
- Silt fence, filter socks, and/or check dams will be installed prior to construction in a given area.
- Construction will primarily be limited to existing road right-of-way and service areas.
- Steel plates will be placed across roadways and driveways for ingress and egress.
- Following completion of construction activities, disturbed areas will be permanently stabilized (i.e., seeded, mulched, and fertilized).

- |                       |                             |                              |                               |
|-----------------------|-----------------------------|------------------------------|-------------------------------|
| Project Study Area    | Wetland Impact              | Off-site Intermittent Stream | Off-Site Wetland              |
| Work Corridor         | Stormwater Inlet            | On-site Ephemeral Stream     | Flood Zones (FEMA)            |
| Construction Entrance | Culvert                     | Off-site Ephemeral Stream    | 1% Annual Chance Flood Hazard |
| Gravel Access Road    | Potential Root Treet        | Delineated Ditch             | Regulatory Floodway           |
| Trench Plug           | Delineated Stream           | Delineated Wetlands          | 2-Foot Contour                |
| Check Dam             | On-site Perennial Stream    | On-site Emergent Wetland     |                               |
| Filter Fence          | Off-site Perennial Stream   | On-site Forested Wetland     |                               |
| Stream Impact         | On-site Intermittent Stream | On-site Shrub Scrub Wetland  |                               |

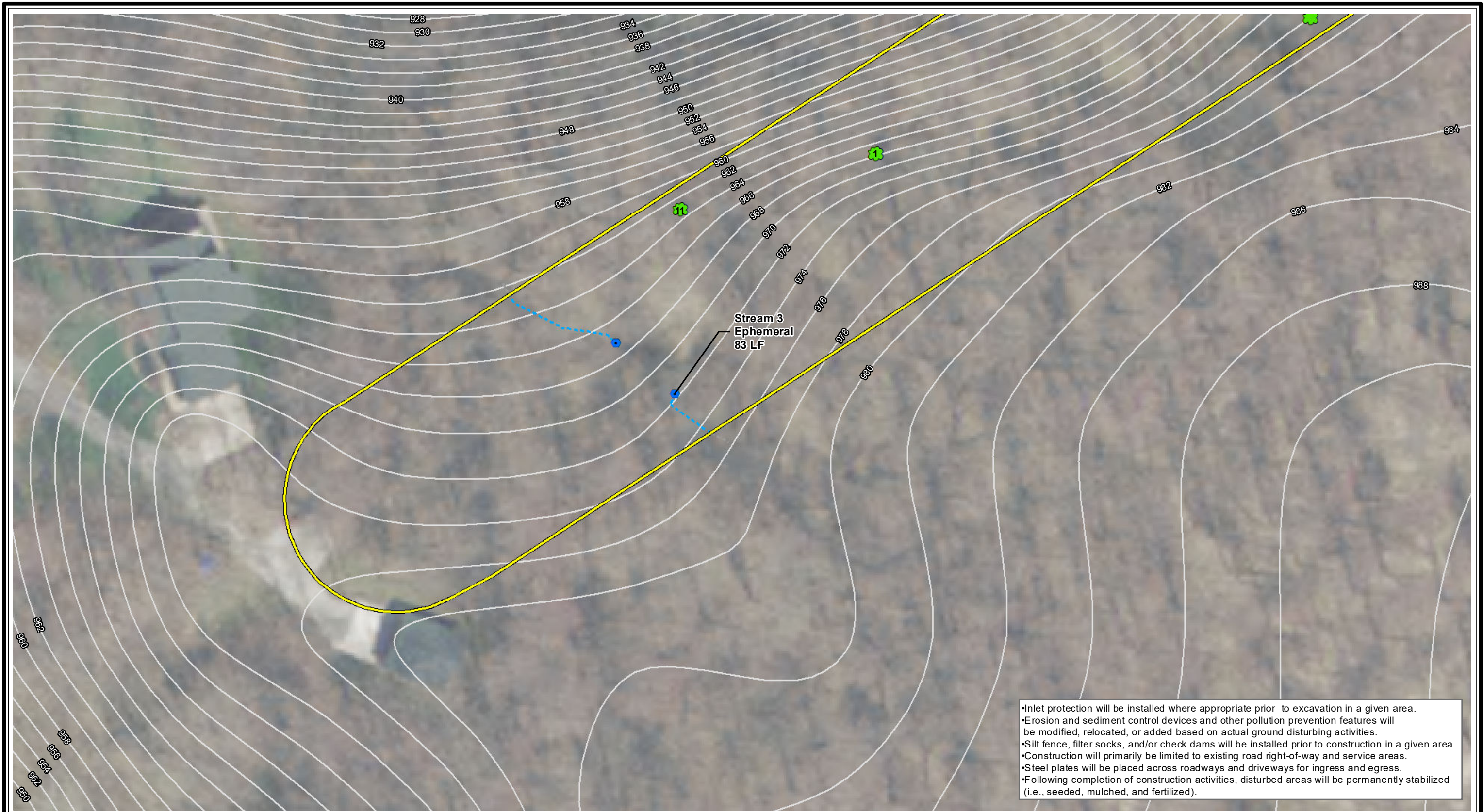


**Appendix C - Figure 1**  
**Erosion and Sediment Control Map 7 of 12**

PIR 2788 - Apple Creek  
 Dominion Energy Ohio  
 Wayne County, Ohio  
 Date: 2/20/2024

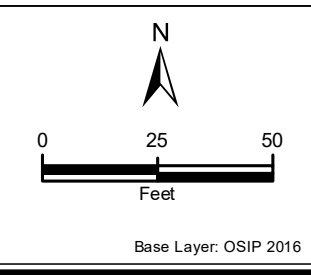
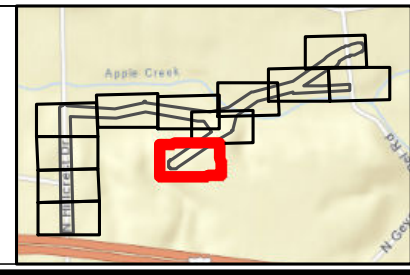






•Inlet protection will be installed where appropriate prior to excavation in a given area.  
 •Erosion and sediment control devices and other pollution prevention features will be modified, relocated, or added based on actual ground disturbing activities.  
 •Silt fence, filter socks, and/or check dams will be installed prior to construction in a given area.  
 •Construction will primarily be limited to existing road right-of-way and service areas.  
 •Steel plates will be placed across roadways and driveways for ingress and egress.  
 •Following completion of construction activities, disturbed areas will be permanently stabilized (i.e., seeded, mulched, and fertilized).

Project Study Area	Wetland Impact	Off-site Intermittent Stream	Off-Site Wetland
Work Corridor	Stormwater Inlet	On-site Ephemeral Stream	Flood Zones (FEMA)
Construction Entrance	Culvert	Off-site Ephemeral Stream	1% Annual Chance Flood Hazard
Gravel Access Road	Potential Roost Tree	Delineated Ditch	Regulatory Floodway
Trench Plug	<b>Delineated Stream</b>	Delineated Wetlands	2-Foot Contour
Check Dam	On-site Perennial Stream	On-site Emergent Wetland	
Filter Fence	Off-site Perennial Stream	On-site Forested Wetland	
Stream Impact	On-site Intermittent Stream	On-site Shrub Scrub Wetland	

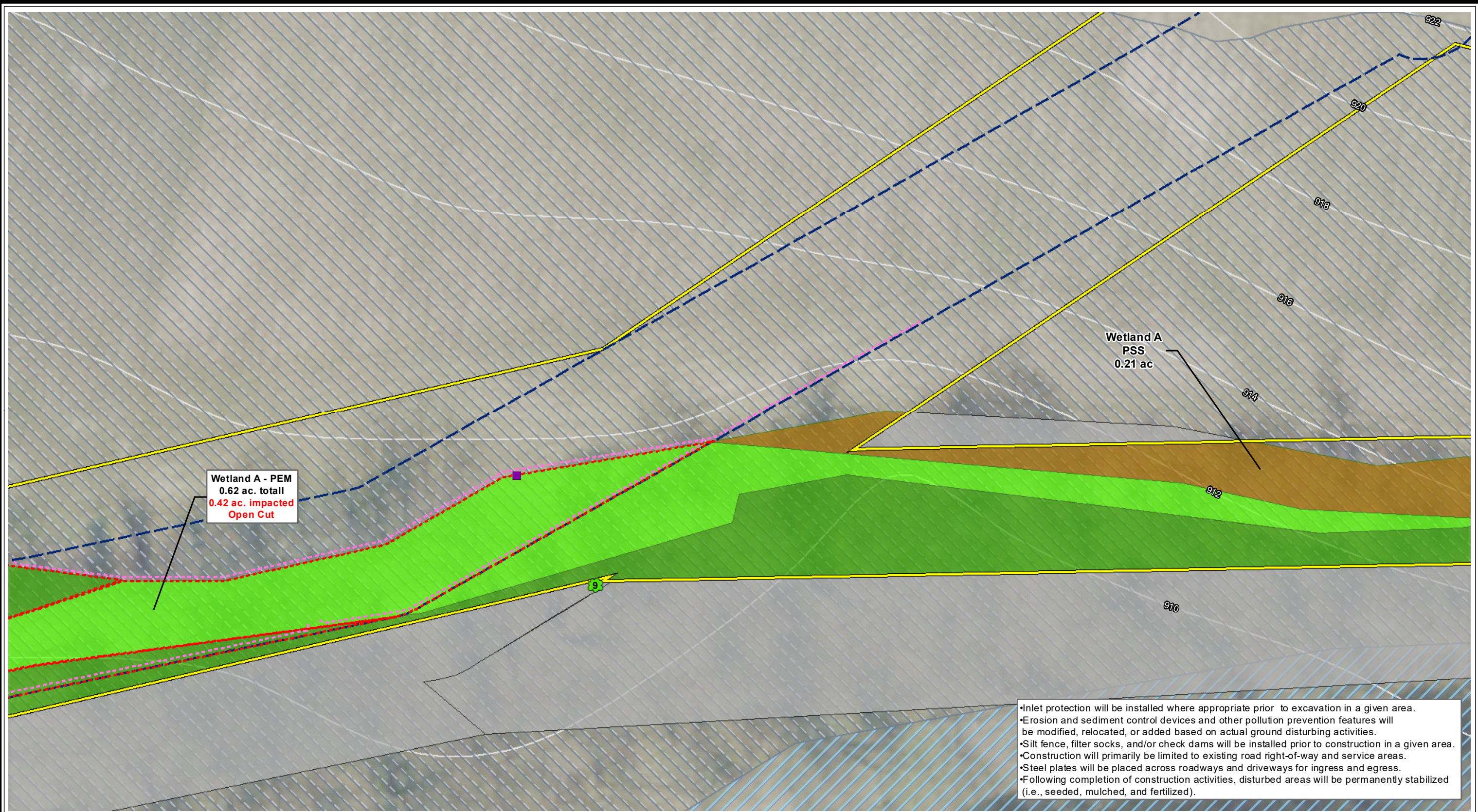


**Appendix C - Figure 1**  
**Erosion and Sediment Control Map 8 of 12**  
 PIR 2788 - Apple Creek  
 Dominion Energy Ohio  
 Wayne County, Ohio  
 Date: 2/20/2024



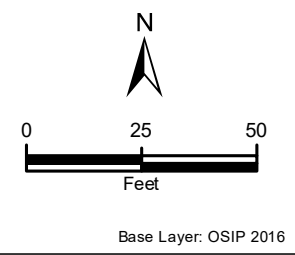
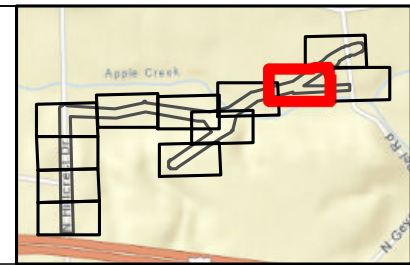






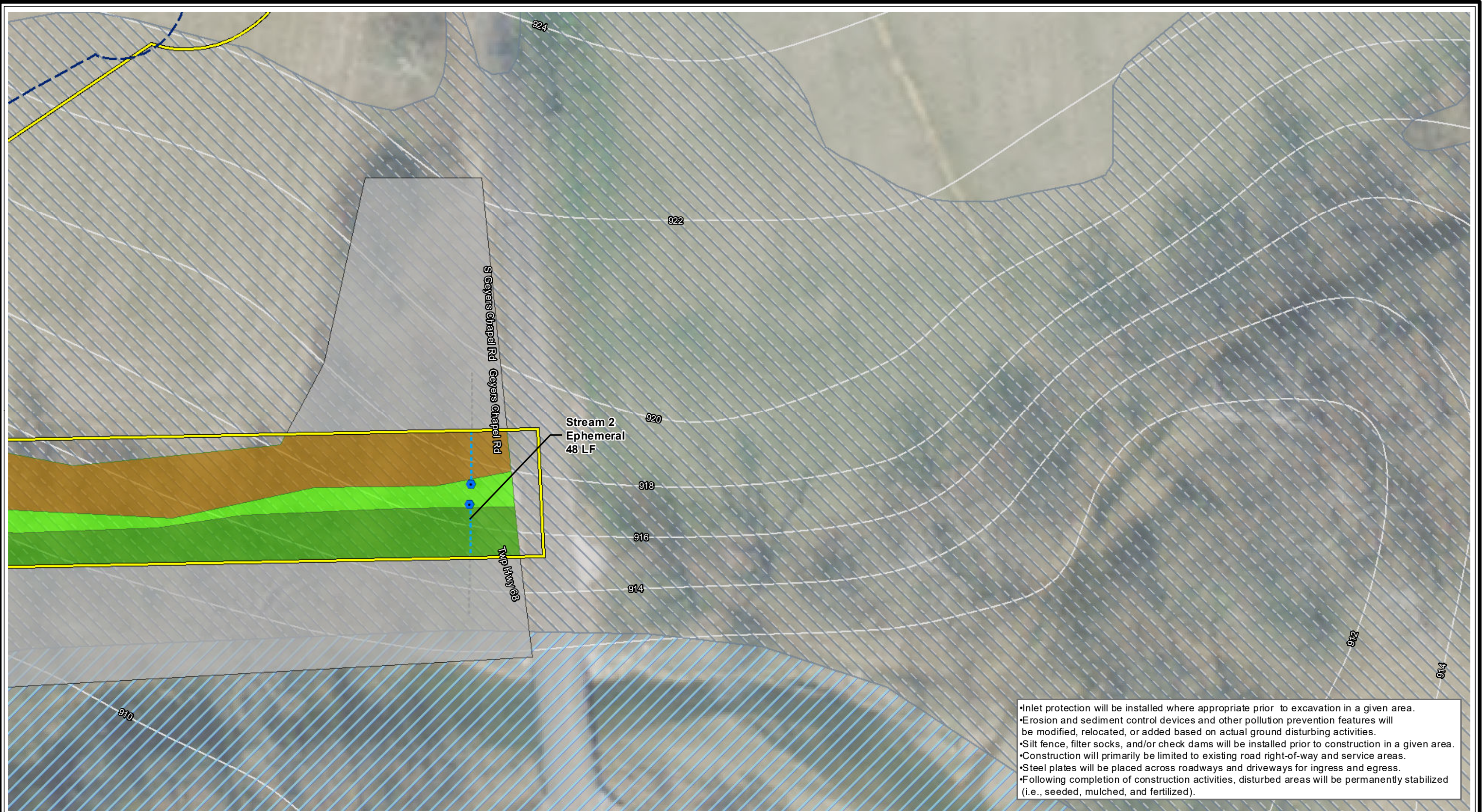
•Inlet protection will be installed where appropriate prior to excavation in a given area.  
 •Erosion and sediment control devices and other pollution prevention features will be modified, relocated, or added based on actual ground disturbing activities.  
 •Silt fence, filter socks, and/or check dams will be installed prior to construction in a given area.  
 •Construction will primarily be limited to existing road right-of-way and service areas.  
 •Steel plates will be placed across roadways and driveways for ingress and egress.  
 •Following completion of construction activities, disturbed areas will be permanently stabilized (i.e., seeded, mulched, and fertilized).

Project Study Area	Wetland Impact	Off-site Intermittent Stream	Off-Site Wetland
Work Corridor	Stormwater Inlet	On-site Ephemeral Stream	Flood Zones (FEMA)
Construction Entrance	Culvert	Off-site Ephemeral Stream	1% Annual Chance Flood Hazard
Gravel Access Road	Potential Root Treet	Delineated Ditch	Regulatory Floodway
Trench Plug	Delineated Stream	Delineated Wetlands	2-Foot Contour
Check Dam	On-site Perennial Stream	On-site Emergent Wetland	
Filter Fence	Off-site Perennial Stream	On-site Forested Wetland	
Stream Impact	On-site Intermittent Stream	On-site Shrub Scrub Wetland	



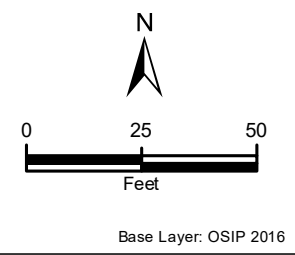
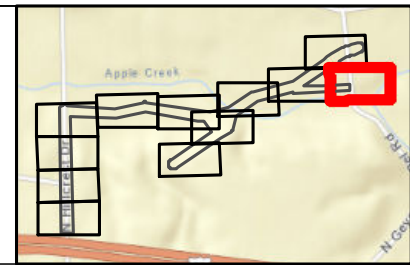
**Appendix C - Figure 1**  
**Erosion and Sediment Control Map 10 of 12**  
 PIR 2788 - Apple Creek  
 Dominion Energy Ohio  
 Wayne County, Ohio  
 Date: 2/20/2024





- Inlet protection will be installed where appropriate prior to excavation in a given area.
- Erosion and sediment control devices and other pollution prevention features will be modified, relocated, or added based on actual ground disturbing activities.
- Silt fence, filter socks, and/or check dams will be installed prior to construction in a given area.
- Construction will primarily be limited to existing road right-of-way and service areas.
- Steel plates will be placed across roadways and driveways for ingress and egress.
- Following completion of construction activities, disturbed areas will be permanently stabilized (i.e., seeded, mulched, and fertilized).

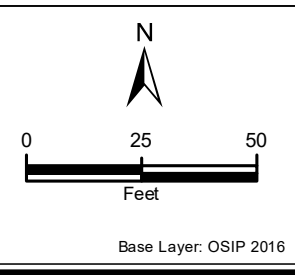
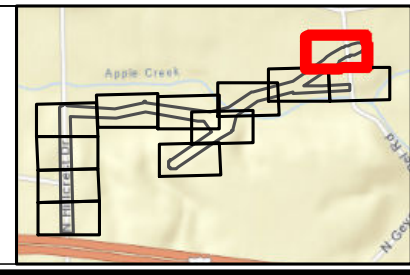
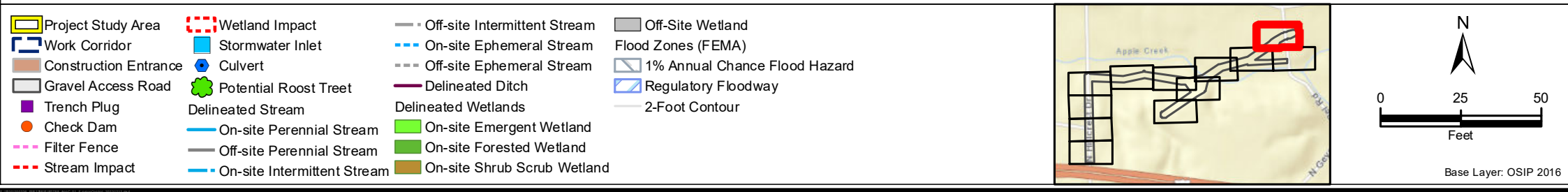
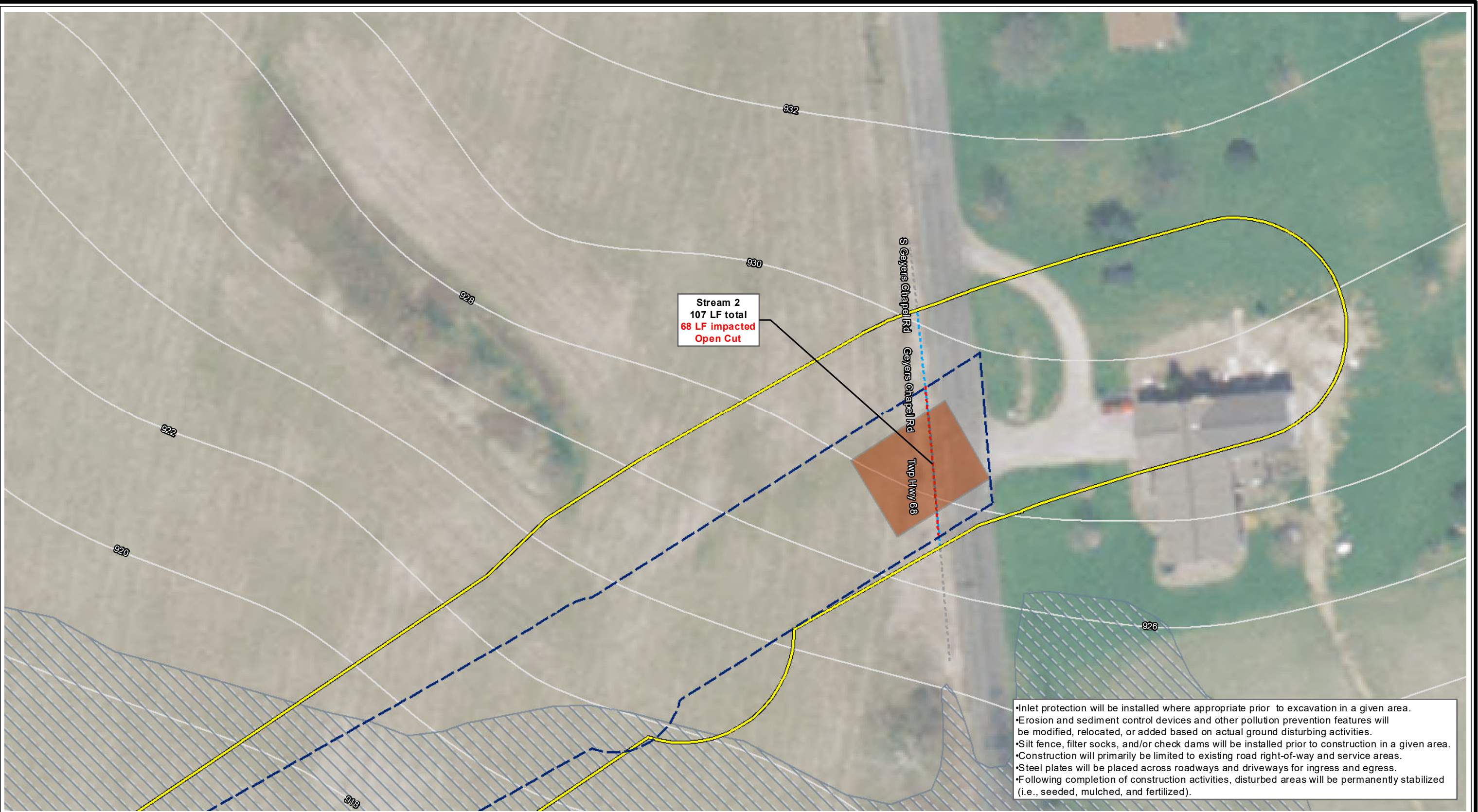
Project Study Area	Wetland Impact	Off-site Intermittent Stream	Off-Site Wetland
Work Corridor	Stormwater Inlet	On-site Ephemeral Stream	Flood Zones (FEMA)
Construction Entrance	Culvert	Off-site Ephemeral Stream	1% Annual Chance Flood Hazard
Gravel Access Road	Potential Root Tree	Delineated Ditch	Regulatory Floodway
Trench Plug	Delineated Stream	Delineated Wetlands	2-Foot Contour
Check Dam	On-site Perennial Stream	On-site Emergent Wetland	
Filter Fence	Off-site Perennial Stream	On-site Forested Wetland	
Stream Impact	On-site Intermittent Stream	On-site Shrub Scrub Wetland	



**Appendix C - Figure 1**  
**Erosion and Sediment Control Map 11 of 12**

PIR 2788 - Apple Creek  
 Dominion Energy Ohio  
 Wayne County, Ohio  
 Date: 2/20/2024





**Appendix C - Figure 1**  
**Erosion and Sediment Control Map 12 of 12**

PIR 2788 - Apple Creek  
 Dominion Energy Ohio  
 Wayne County, Ohio  
 Date: 2/20/2024

---

## **APPENDIX D**

### **Site Drawing Checklist and Logs**

## **D-1 SITE DRAWING CHECKLIST \*\***

- **Location of solid waste dumpsters**
- **Location designated for waste drums of oil soaked absorbent pads/rags; solids, sludge, or oil collected from pipeline**
- **Locations of sanitary facilities such as Port-a-Jons (update these locations on drawings as project progresses)**
- **Locations of diesel and gasoline storage tanks (secondary containment provided)**
- **Locations of pipe and equipment storage yards**
- **Locations of cement truck washout**

**\*\* *These locations can be hand drawn on the site drawings.***







---

## **APPENDIX E**

### **Corrective Action Log**





**Dominion Construction Stormwater General Permit: Corrective Action Log**

**Project Name:**

**State-Specific Corrective Action Requirement\*:**

**Positions Authorized to Document Corrective Action Completion:**

Corrective Action #	Inspection Date	Inspector Name(s)	Description of Deficiency	Corrective Action Required	Date Corrective Action is Due*	Agency Notification Required? (Y/N)	Date Corrective Action Performed / Responsible Person

\*Corrective action requirements/deadlines are state specific. Thus, refer to your construction stormwater permit. Should the project team not be able to meet the permit deadlines then the stormwater management program authority (e.g. state agency) must be notified.

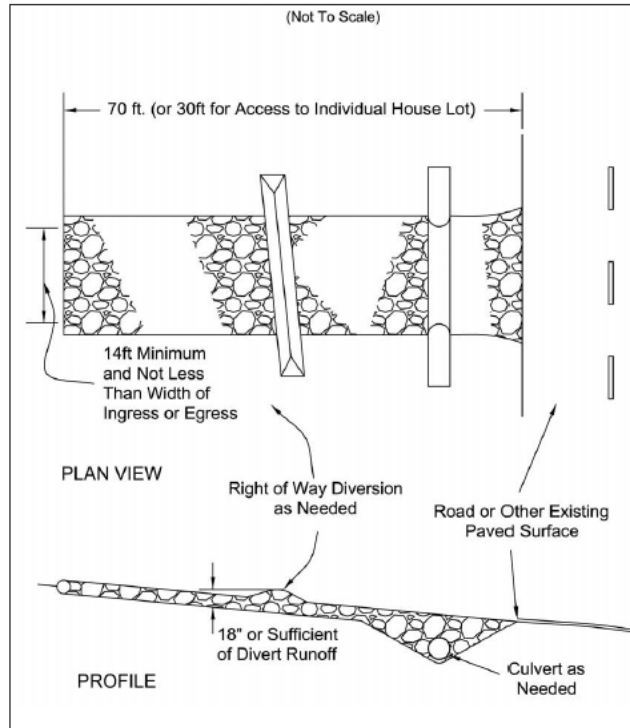
---

## **APPENDIX F**

# **Typical Upland Erosion and Sediment Control Plan Drawings**

# DETAIL F-1

## ROCK CONSTRUCTION ENTRANCE DETAIL



Specifications  
for

### Construction Entrance

1. Stone Size—ODOT # 2 (1.5-2.5 inch) stone shall be used, or recycled concrete equivalent.
2. Length—The Construction entrance shall be as long as required to stabilize high traffic areas but not less than 70 ft. (exception: apply 30 ft. minimum to single residence lots).
3. Thickness -The stone layer shall be at least 6 inches thick for light duty entrances or at least 10 inches for heavy duty use.
4. Width -The entrance shall be at least 14 feet wide, but not less than the full width at points where ingress or egress occurs.
5. Geotextile -A geotextile shall be laid over the entire area prior to placing stone. It shall be composed of strong rot-proof polymeric fibers and meet the following specifications:
6. Timing—The construction entrance shall be installed as soon as is practicable before major grading activities.
7. Culvert -A pipe or culvert shall be constructed under the entrance if needed to prevent surface water from flowing across the entrance or to prevent runoff from being directed out onto paved surfaces.
8. Water Bar -A water bar shall be constructed as part of the construction entrance if needed to prevent surface runoff from flowing the length of the construction entrance and out onto paved surfaces.
9. Maintenance -Top dressing of additional stone shall be applied as conditions demand. Mud spilled, dropped, washed or tracked onto public roads, or any surface where runoff is not checked by sediment controls, shall be removed immediately. Removal shall be accomplished by scraping or sweeping.
10. Construction entrances shall not be relied upon to remove mud from vehicles and prevent off-site tracking. Vehicles that enter and leave the construction-site shall be restricted from muddy areas.
11. Removal—the entrance shall remain in place until the disturbed area is stabilized or replaced with a permanent roadway or entrance.

Figure 7.4.1

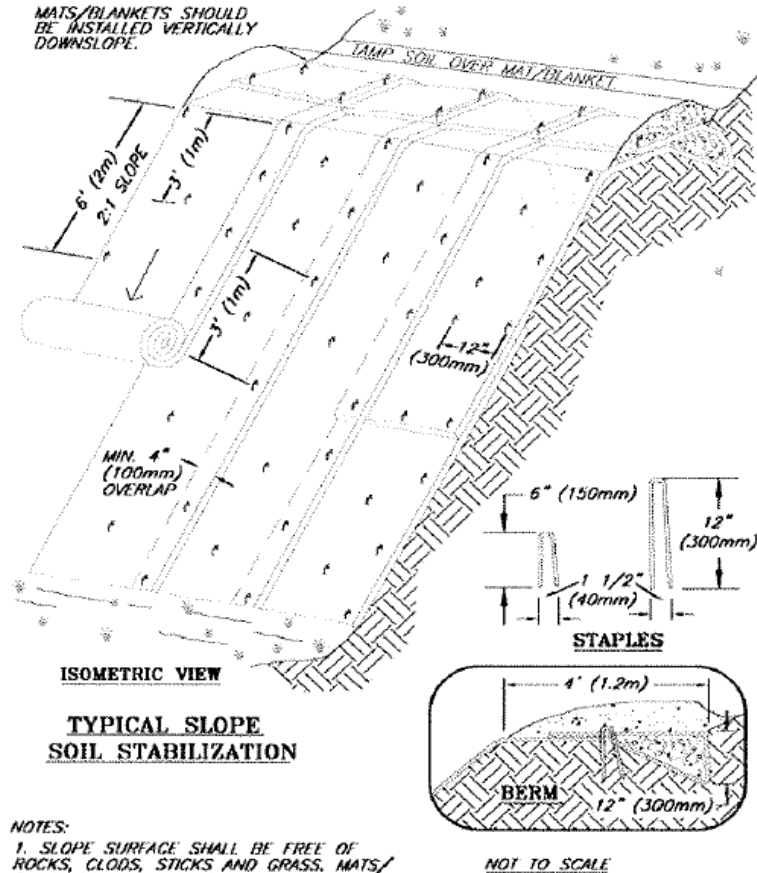
Geotextile Specification for Construction Entrance	
Minimum Tensile Strength	200 lbs.
Minimum Puncture Strength	80 psi.
Minimum Tear Strength	50 lbs.
Minimum Burst Strength	320 psi.
Minimum Elongation	20%
Equivalent Opening Size	EOS < 0.6 mm.
Permittivity	1×10 <sup>-3</sup> cm/sec.



# DETAIL F-2

## EROSION CONTROL MATTING DETAIL

### EROSION CONTROL BLANKET DETAIL



**NOTES:**

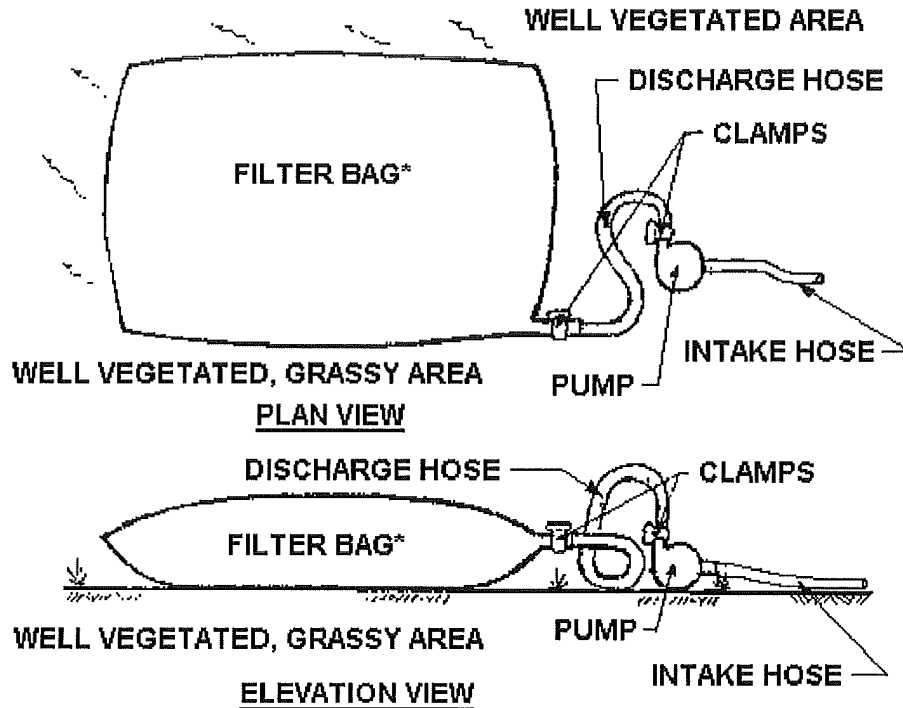
1. SLOPE SURFACE SHALL BE FREE OF ROCKS, CLODS, STICKS AND GRASS. MATS/BLANKETS SHALL HAVE GOOD SOIL CONTACT.
2. APPLY PERMANENT SEEDING BEFORE PLACING BLANKETS.
3. LAY BLANKETS LOOSELY AND STAKE OR STAPLE TO MAINTAIN DIRECT CONTACT WITH THE SOIL. DO NOT STRETCH.

**EROSION BLANKETS & TURF REINFORCEMENT MATS SLOPE INSTALLATION**

Refer to manufacturer's lining installation detail for overlap, embedment, staple patterns, and vegetative stabilization specifications

## DETAIL F-3

### PUMPED WATER FILTER BAG DETAIL



Filter bags shall be made from non-woven geotextile material sewn with high strength, double stitched "J" type seams. They shall be capable of trapping particles larger than 150 microns.

A suitable means of accessing the bag with machinery required for disposal purposes must be provided. Filter bags shall be replaced when they become 1/2 full. Spare bags shall be kept available for replacement of those that have failed or are filled.

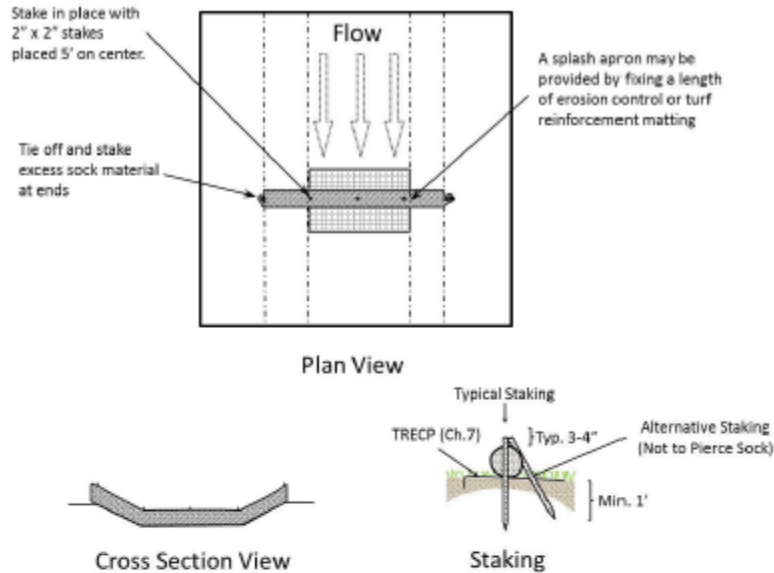
Bags shall be located in a well-vegetated (grassy) area, and discharge onto stable, erosion resistant areas. Where this is not possible, a geotextile flow path shall be provided. Bags should not be placed on slopes greater than 5%.

For hydrostatic discharge, the pumping rate is 350-500 gallons per minute (gpm). For trench dewatering, the pumping rate shall be no more than 750 gpm. Floating pump intakes should be considered to allow sediment-free water to be discharged during dewatering.

Filter bags shall be inspected daily. If any problem is detected, pumping shall cease immediately and not resume until the problem is corrected.

# DETAIL F-4

## COMPOST SOCK CHECK DAM DETAIL

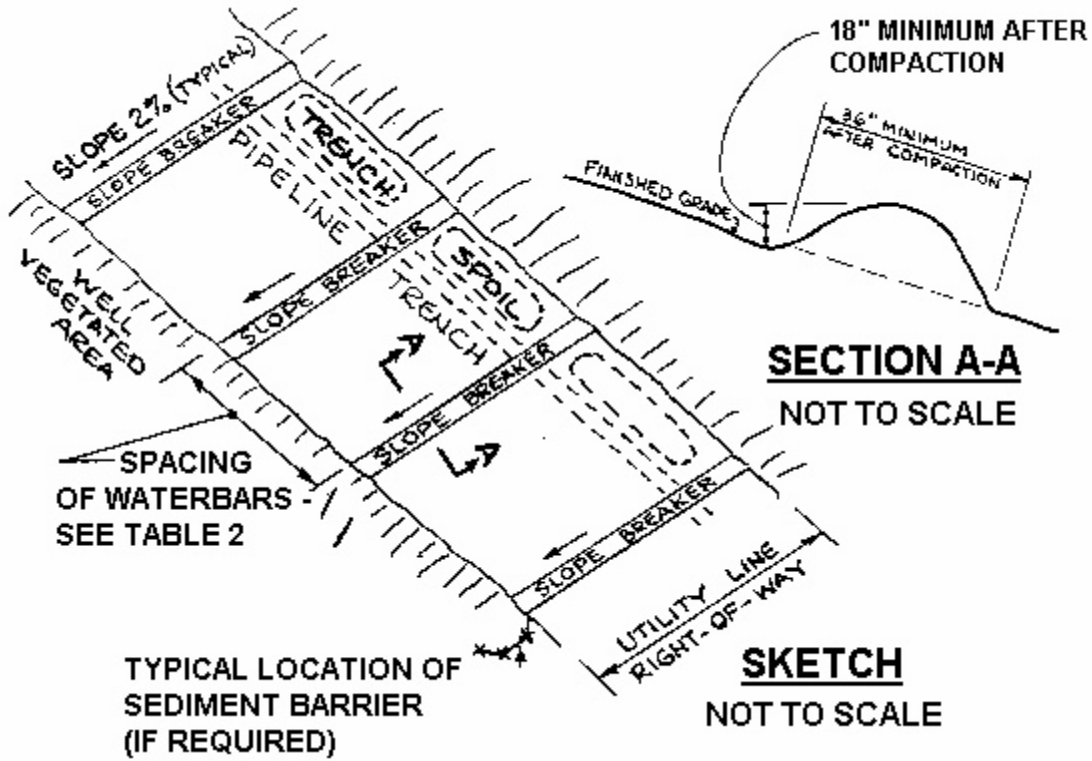


1. Compost sock netting shall use a knitted mesh fabric with 1/8-3/8 inch openings, and compost media with particle sizes 99% < 3 inches, and 60% > 3/8 inches (conforming to media described in Chapter 6 Filter Sock).
2. Compost sock check dams shall be used in areas that drain 5 acres or less.
3. Sediment shall be removed from behind the sock when it reaches 1/2 the height of the check dam.
4. Compost sock check dams shall be constructed with 12, 18, or 24 in diameter compost socks, and shall completely cover the width of the channel. The midpoint of the compost sock check dam shall be a minimum of 6 inches lower than the sides in order to direct flow across the center and away from the channel sides. Filter sock check dams shall be filled to a density such that they shall reach their intended height (diameter). After installation and use, they shall be considered unsuitable and in need of replacement after falling below 80% of their minimum required height (diameter).
5. Although no trenching is necessary, compost sock check dams shall be placed on a graded surface where consistent contact with the soil surface is made without bridging over gaps, rills, gullies, stones or other irregularities.
6. Place compost sock check dams so that the ends extend to the top of bank. Staking for compost sock check dams shall use 2 inch x 2 inch wooden stakes, placed 5 foot on center. Stake length shall allow them to be driven 12 inches into existing soil and allow at least 2 inches above the sock.
7. Space compost sock check dams so that the toe of the upstream dam is at the same elevation or lower elevation as the top of the downstream compost sock check dam (at the center of the channel). This will be influenced by the height of the sock and gradient of the waterway.
8. A splash apron may be needed where flows over the sock may erode the channel and undercut the compost sock check dam. Create the apron by fixing a length of Temporary Rolled Erosion Control Product (Erosion Control Matting) or Turf Reinforcement Matting starting upstream of the sock a distance equal to the sock height and extending a length two times the height of the compost sock check dam. See Chapter 7 for information regarding these materials. Materials used should be able to be left in place (e.g. biodegradable/photodegradable TRECP) without creating problems for future mowing or maintenance of the channel.



# DETAIL F-5

## WATERBAR INSTALLATION

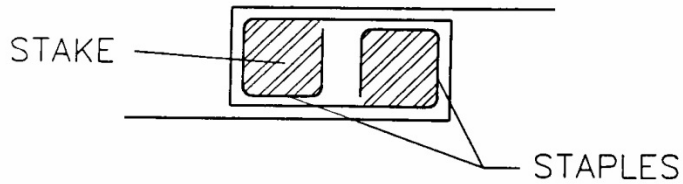


Required Spacing for Temporary and Permanent Waterbars	
Percent Slope	Spacing (FT)
1	400
2	250
5	135
10	80
15	60
20	45

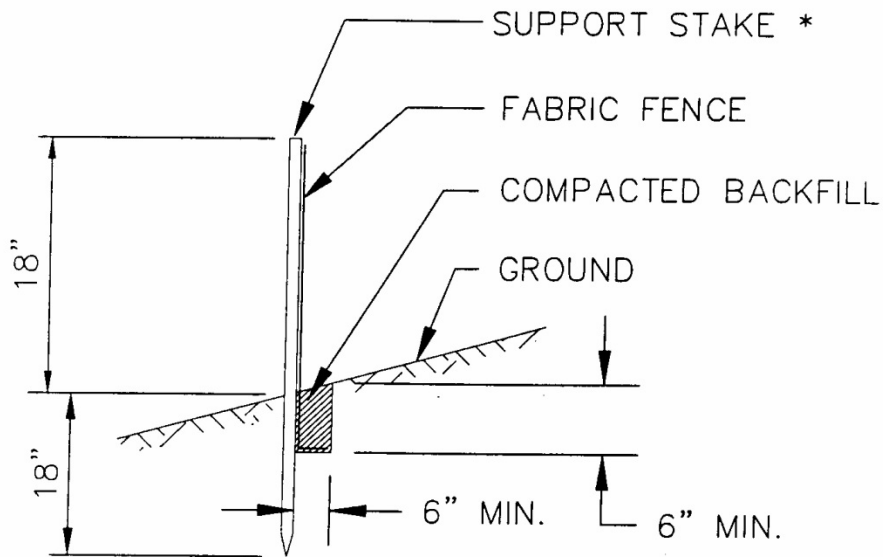
Waterbars should be constructed at a slope of 1% and discharge to a well-vegetated area. Waterbars should not discharge into an open trench. Waterbars should be oriented so that the discharge does not flow back onto the ROW. Obstructions, (e.g. silt fence, rock filters, etc.) should not be placed in any waterbars. Where needed, they should be located below the discharge end of the waterbar.

## DETAIL F-6

### FILTER FABRIC FENCE DETAIL



### JOINING FENCE SECTIONS



\*Stakes spaced @ 8' maximum. Use 2"x 2" wood or equivalent steel stakes.

Filter Fabric Fence must be placed at level existing grade. Both ends of the barrier must be extended at least 8 feet up slope at 45 degrees to the main barrier alignment.

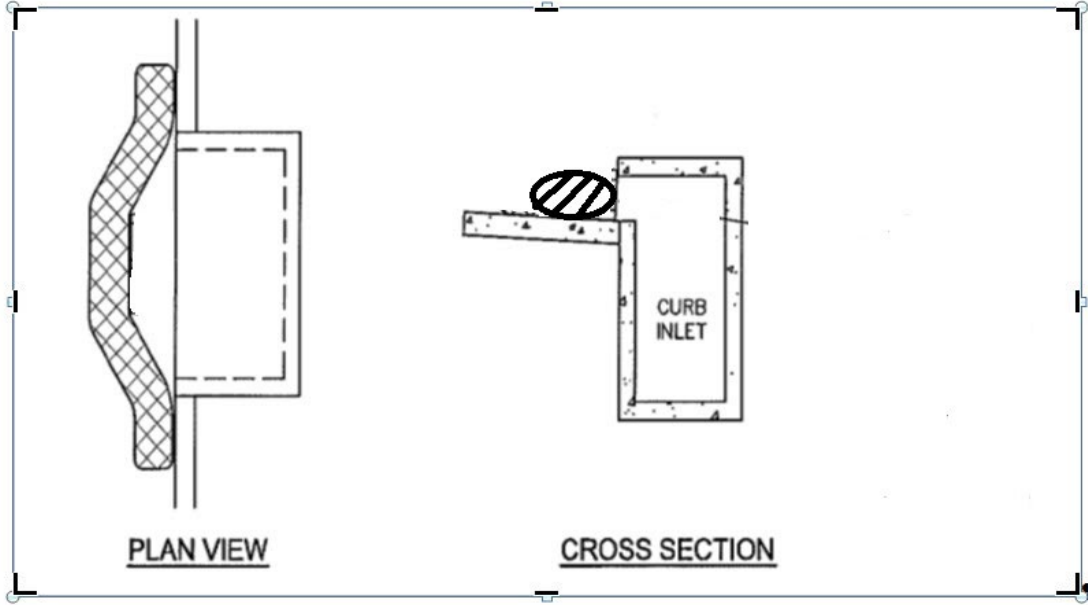
Trench shall be backfilled and compacted to prevent runoff from cutting underneath the fence.

Sediment must be removed when accumulations reach 1/2 the above ground height of the fence.

Any section of Filter fabric fence that has been undermined or topped should be immediately replaced.

# **DETAIL F-7A**

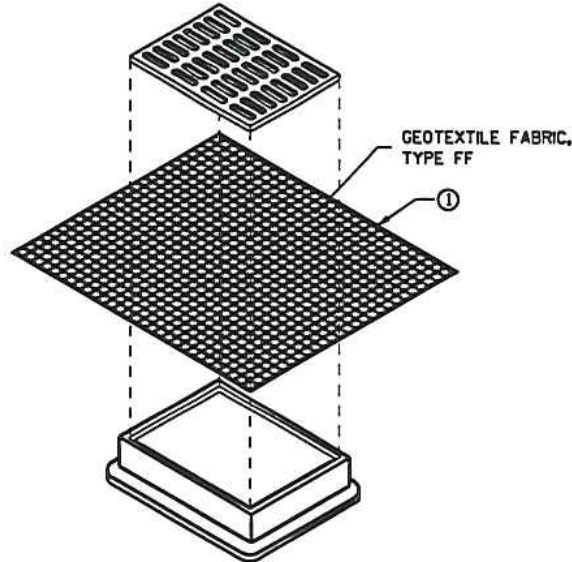
## **CURB INLET PROTECTION**





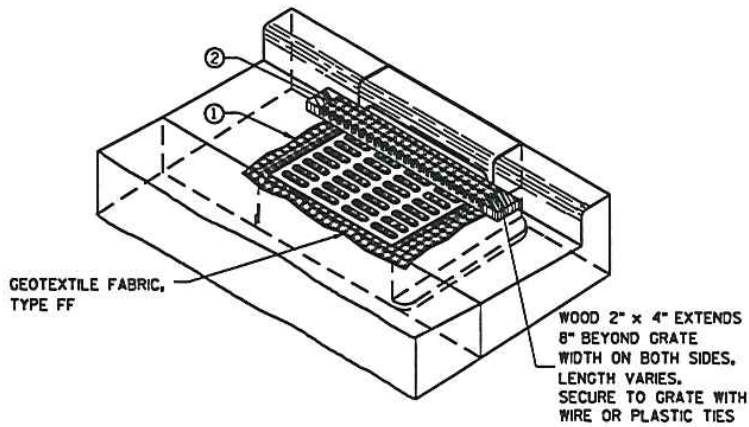
# **DETAIL F-7B**

## **CURB INLET PROTECTION**



### **INLET PROTECTION, TYPE B (WITHOUT CURB BOX)**

(CAN BE INSTALLED IN ANY INLET WITHOUT A CURB BOX)



### **INLET PROTECTION, TYPE C (WITH CURB BOX)**

## **INSTALLATION NOTES**

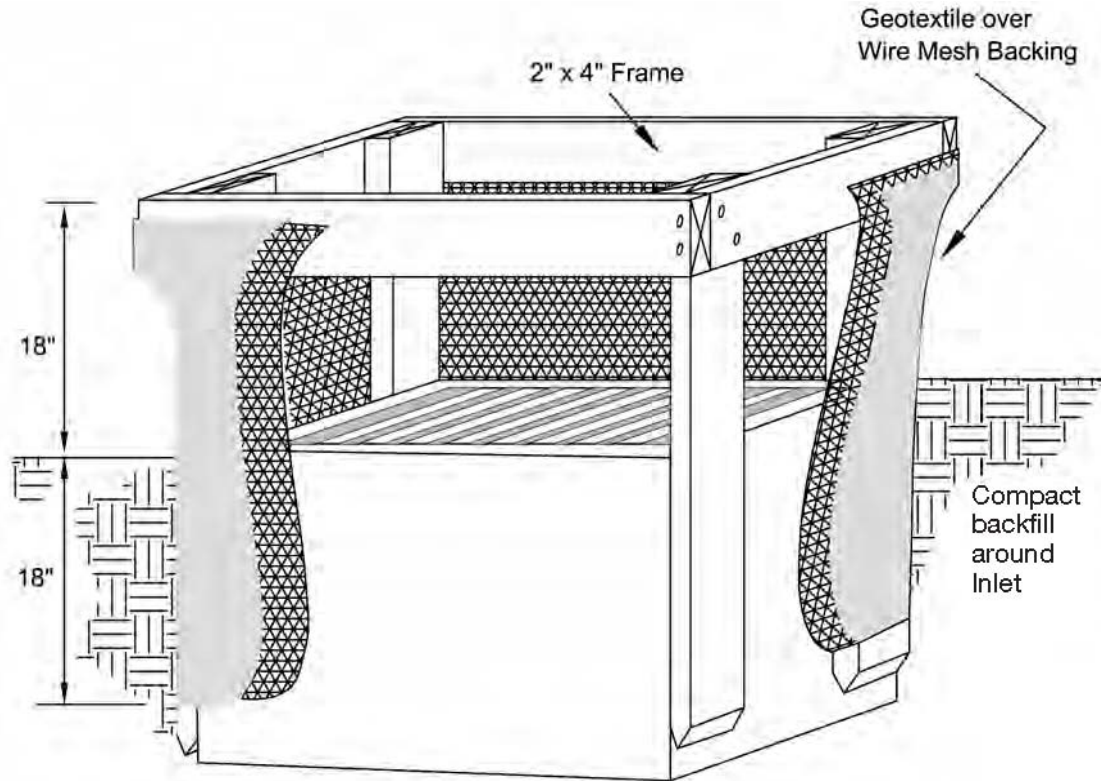
### **TYPE B & C**

TRIM EXCESS FABRIC IN THE FLOW LINE TO WITHIN 3" OF THE GRATE.

THE CONTRACTOR SHALL DEMONSTRATE A METHOD OF MAINTENANCE, USING A SEWN FLAP, HAND HOLDS OR OTHER METHOD TO PREVENT ACCUMULATED SEDIMENT FROM ENTERING THE INLET.

## **DETAIL F-7C**

### **GEOTEXTILE INLET PROTECTION DETAIL**

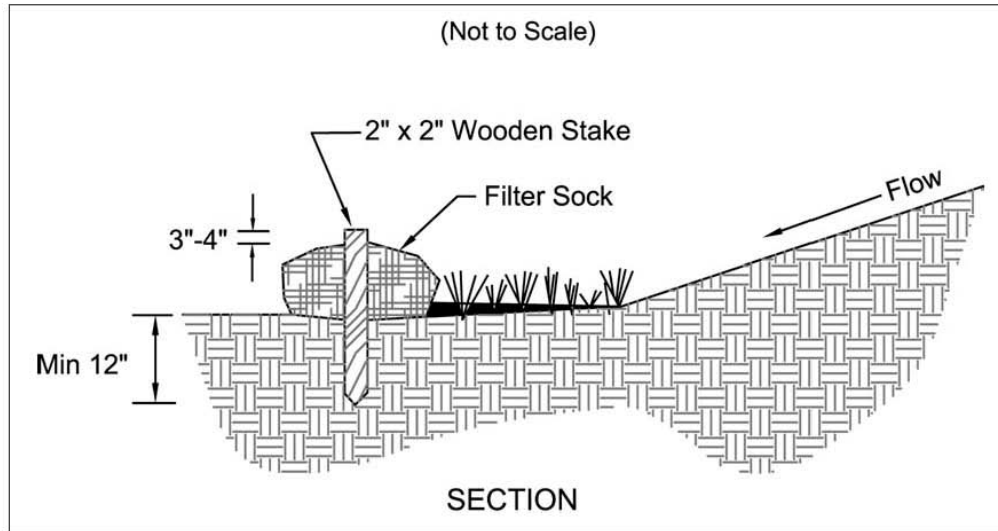


### **SECTION**

1. Inlet protection shall be constructed either before upslope land disturbance begins or before the inlet becomes functional.
2. The earth around the inlet shall be excavated completely to a depth at least 18 inches.
3. The wooden frame shall be constructed of 2-inch by 4-inch construction grade lumber. The 2-inch by 4-inch posts shall be driven one (1) ft. into the ground at four corners of the inlet and the top portion of 2-inch by 4-inch frame assembled using the overlap joint shown. The top of the frame shall be at least 6 inches below adjacent roads if ponded water will pose a safety hazard to traffic.
4. Wire mesh shall be of sufficient strength to support fabric with water fully impounded against it. It shall be stretched tightly around the frame and fastened securely to the frame.
5. Geotextile material shall have an equivalent opening size of 20-40 sieve and be resistant to sunlight. It shall be stretched tightly around the frame and fastened securely. It shall extend from the top of the frame to 18 inches below the inlet notch elevation. The geotextile shall overlap across one side of the inlet so the ends of the cloth are not fastened to the same post.
6. Backfill shall be placed around the inlet in compacted 6inch layers until the earth is even with notch elevation on ends and top elevation on sides.
7. A compacted earth dike or check dam shall be constructed in the ditch line below the inlet if the inlet is not in a depression. The top of the dike shall be at least 6 inches higher than the top of the frame.
8. Filter fabric and filter socks can also be used as inlet protection.

# DETAIL F-8

## FILTER SOCK DETAIL



1. Materials – Compost used for filter socks shall be weed, pathogen and insect free and free of any refuse, contaminants or other materials toxic to plant growth. They shall be derived from a well-decomposed source of organic matter and consist of particles ranging from 3/8" to 2".
2. Filter Socks shall be 3 or 5 mil continuous, tubular, HDPE 3/8" knitted mesh netting material, filled with compost passing the above specifications for compost products.

### INSTALLATION:

3. Filter socks will be placed on a level line across slopes, generally parallel to the base of the slope or other affected area. On slopes approaching 2:1, additional socks shall be provided at the top and as needed mid-slope.
4. Filter socks intended to be left as a permanent filter or part of the natural landscape, shall be seeded at the time of installation for establishment of permanent vegetation.

5. Filter Socks are not to be used in concentrated flow situations or in runoff channels.

### MAINTENANCE:

6. Routinely inspect filter socks after each significant rain, maintaining filter socks in a functional condition at all times.
7. Remove sediments collected at the base of the filter socks when they reach 1/3 of the exposed height of the practice.
8. Where the filter sock deteriorates or fails, it will be repaired or replaced with a more effective alternative.
9. Removal – Filter socks will be dispersed on site when no longer required in such a way as to facilitate and not obstruct seedings.

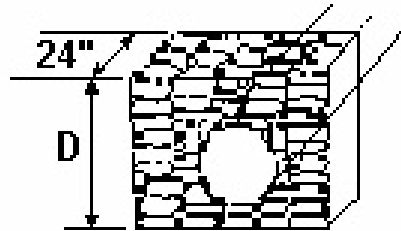
Note: Filter socks may not require stakes if used in areas of little to no slope, for short duration, and/or for relatively small disturbances such as sidecast piles from service line tie-ins.



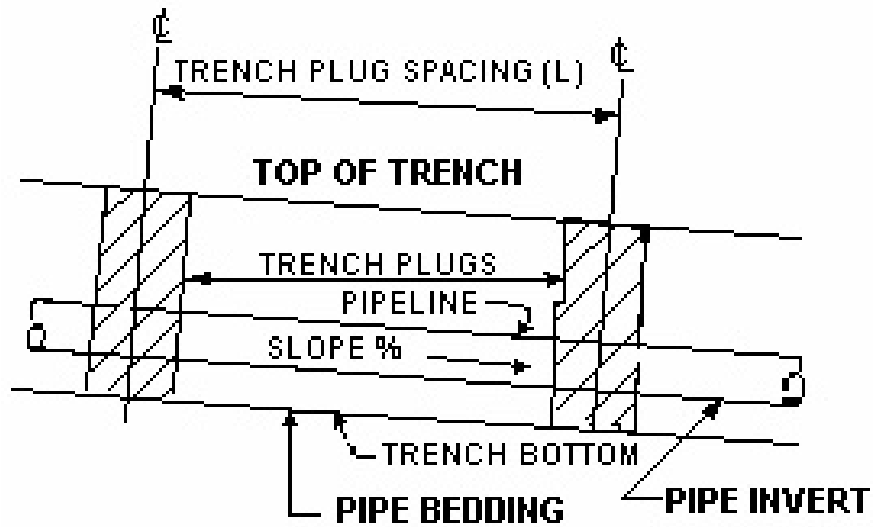
# DETAIL F-9

## TRENCH PLUG INSTALLATION DETAIL

D - DEPTH TO BOTTOM OF TRENCH



### SECTION VIEW NOT TO SCALE



### ELEVATION NOT TO SCALE

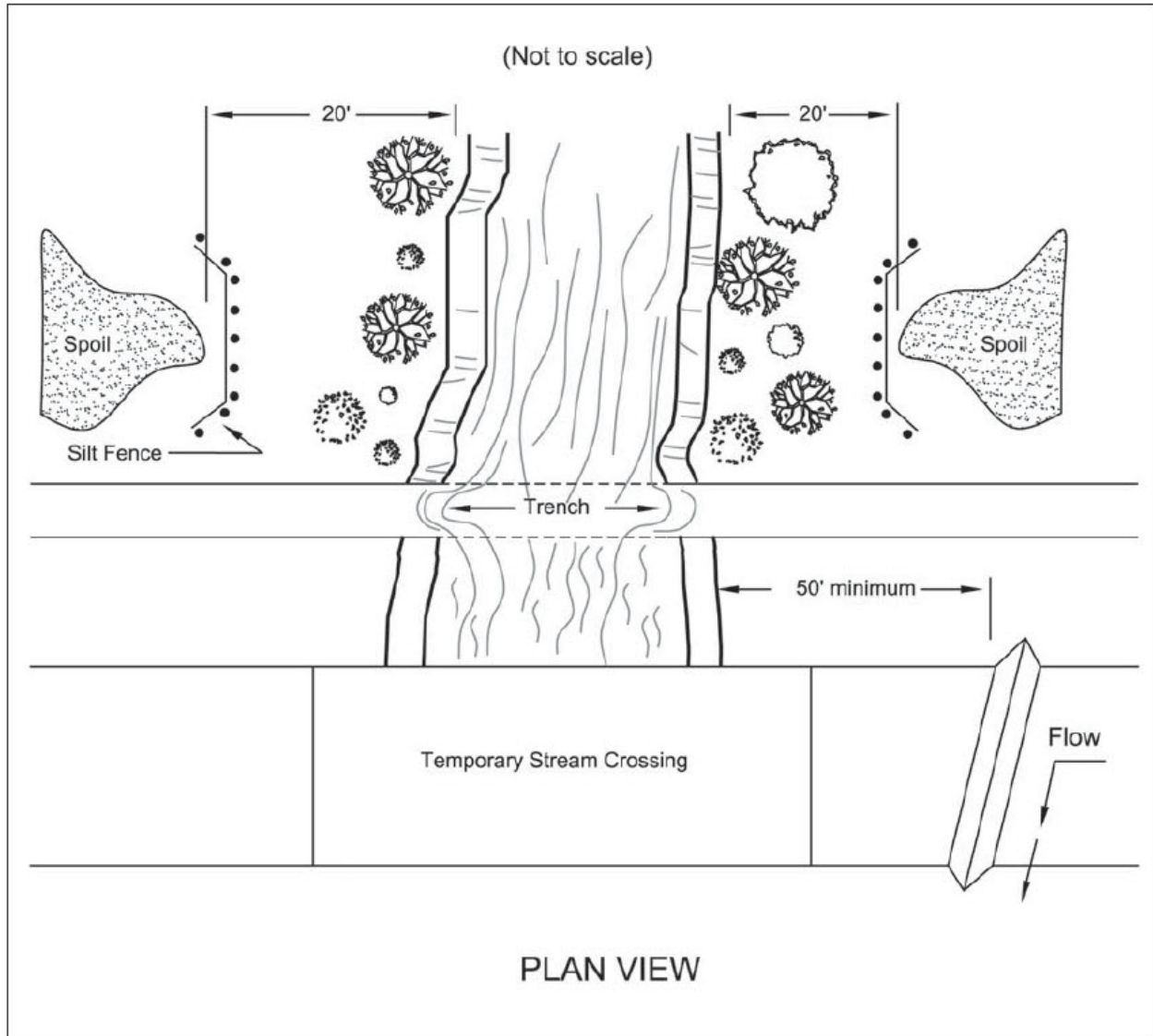
---

## **APPENDIX G**

# **Typical Stream Crossing Drawings**

# **DETAIL G-1**

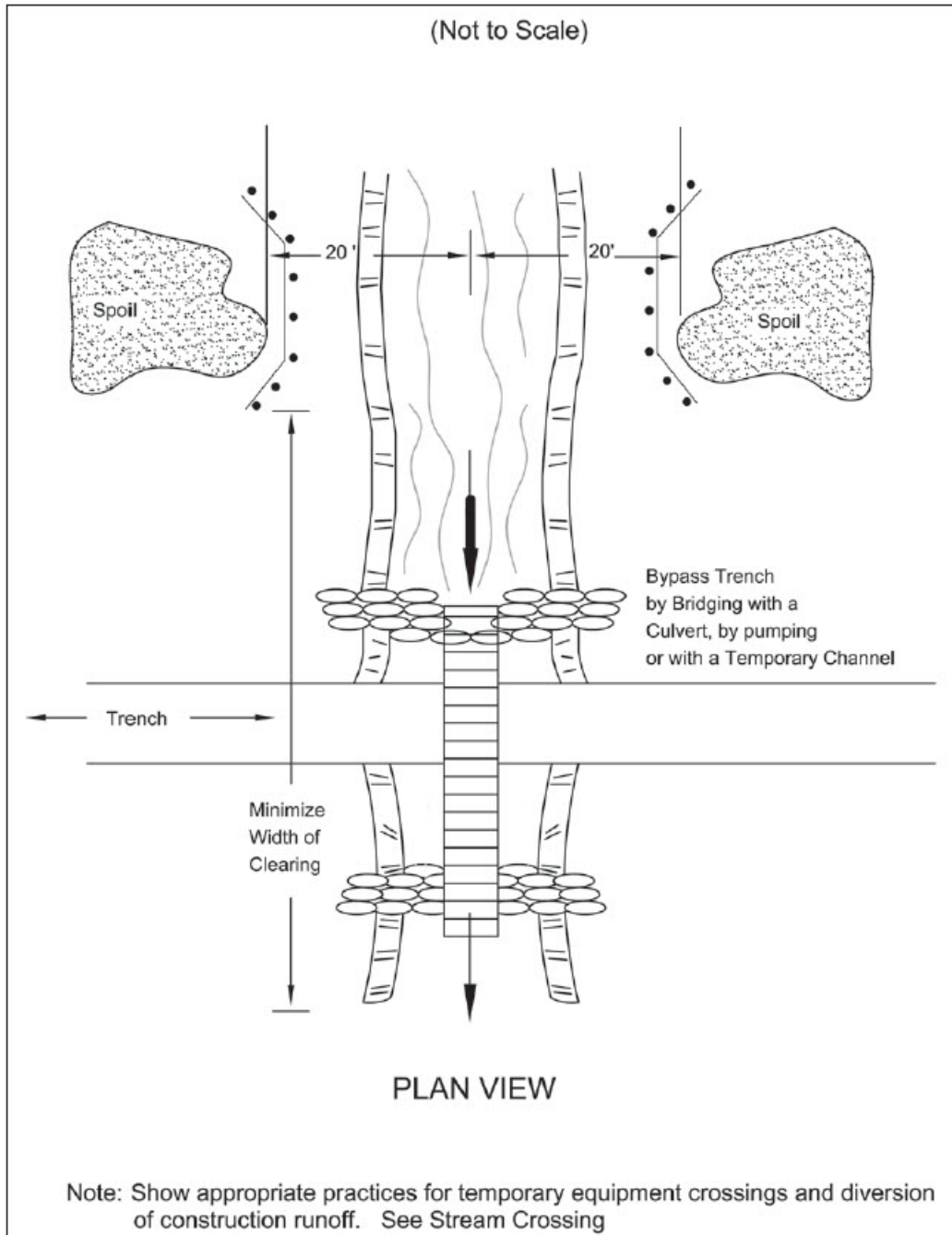
## **LARGE STREAM UTILITY CROSSING**





## **DETAIL G-2**

### **SMALL STREAM UTILITY CROSSING**

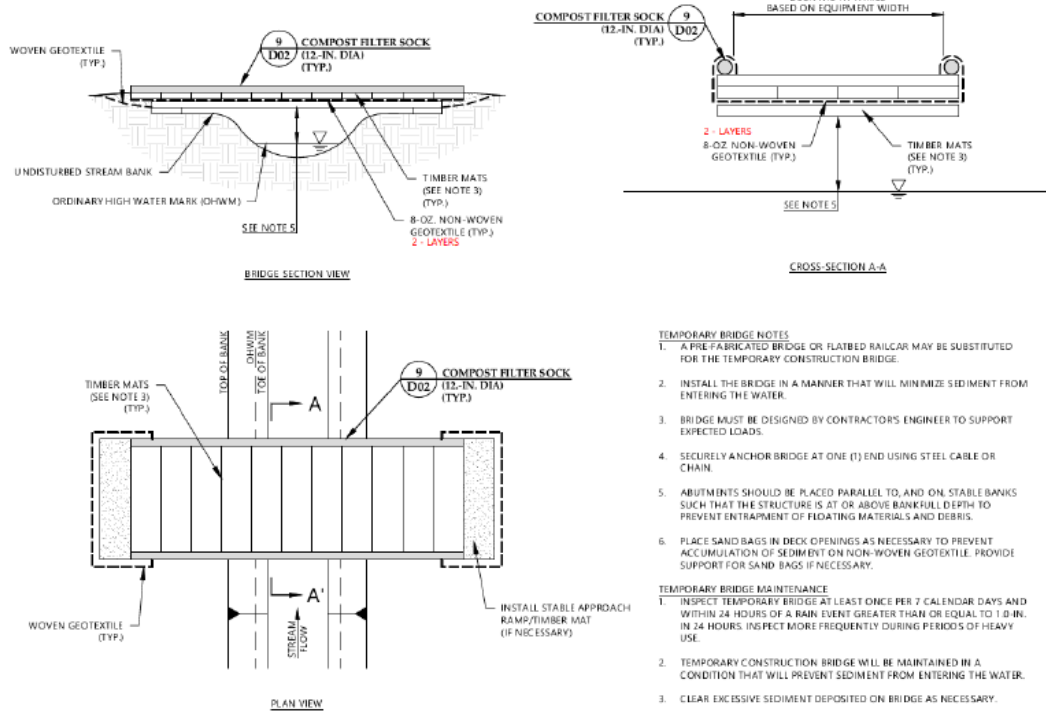


Notes: A diversion barrier may also be used to direct water away from the pipe trench  
Trench plugs will be installed as necessary on each side of water body crossings.

# DETAIL G-3

## TEMPORARY ACCESS BRIDGE

### TEMPORARY ACCESS BRIDGE



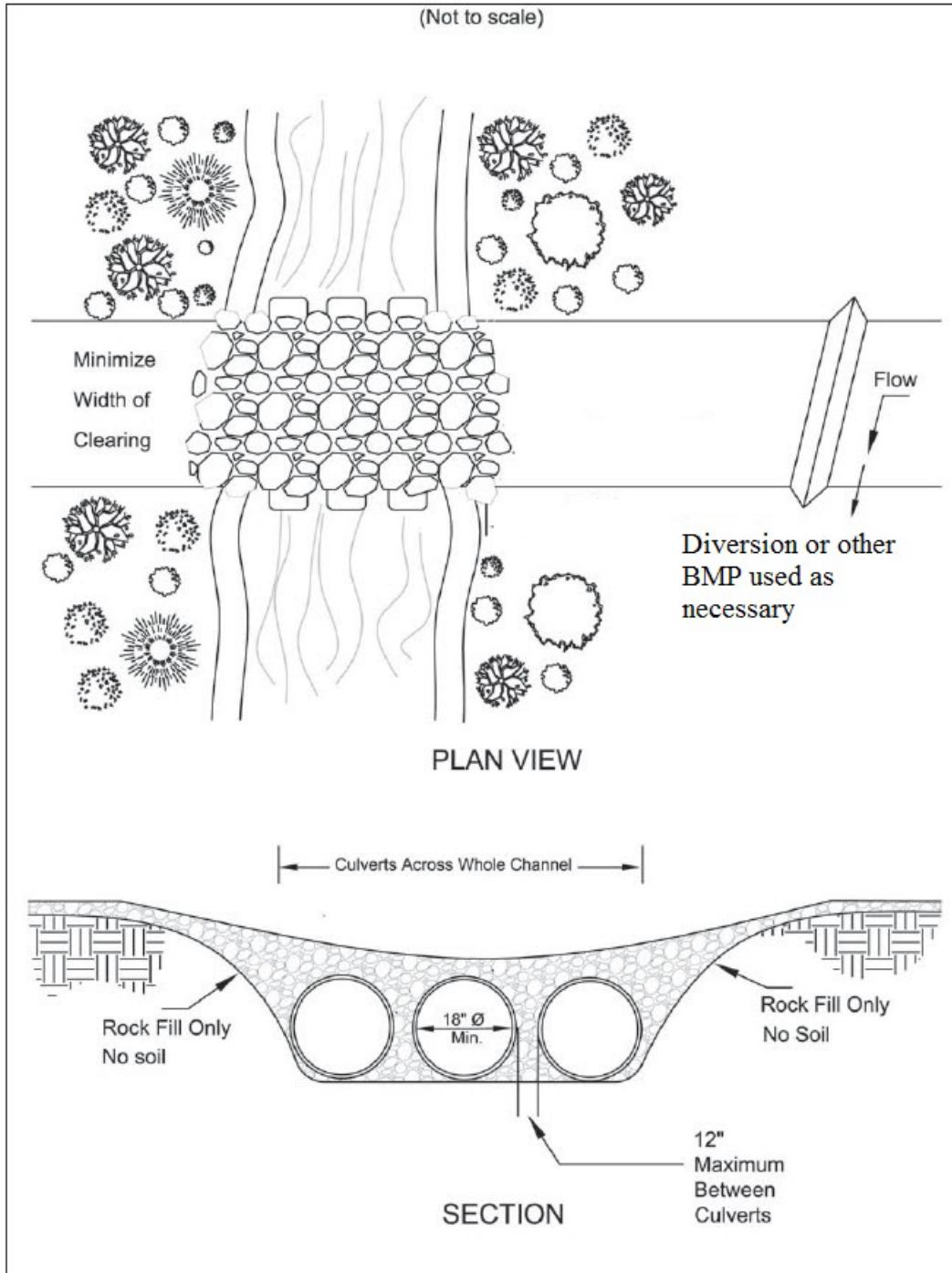
- TEMPORARY BRIDGE NOTES**
1. A PRE-FABRICATED BRIDGE OR FLATBED RAILCAR MAY BE SUBSTITUTED FOR THE TEMPORARY CONSTRUCTION BRIDGE.
  2. INSTALL THE BRIDGE IN A MANNER THAT WILL MINIMIZE SEDIMENT FROM ENTERING THE WATER.
  3. BRIDGE MUST BE DESIGNED BY CONTRACTOR'S ENGINEER TO SUPPORT EXPECTED LOADS.
  4. SECURELY ANCHOR BRIDGE AT ONE (1) END USING STEEL CABLE OR CHAIN.
  5. ABUTMENTS SHOULD BE PLACED PARALLEL TO, AND ON, STABLE BANKS SUCH THAT THE STRUCTURE IS AT OR ABOVE BANKFULL DEPTH TO PREVENT ENTRAPMENT OF FLOATING MATERIALS AND DEBRIS.
  6. PLACE SAND BAGS IN DECK OPENINGS AS NECESSARY TO PREVENT ACCUMULATION OF SEDIMENT ON NON-WOVEN GEOTEXTILE. PROVIDE SUPPORT FOR SAND BAGS IF NECESSARY.
- TEMPORARY BRIDGE MAINTENANCE**
1. INSPECT TEMPORARY BRIDGE AT LEAST ONCE PER 7 CALENDAR DAYS AND WITHIN 24 HOURS OF A RAIN EVENT GREATER THAN OR EQUAL TO 1.0 IN. IN 24 HOURS. INSPECT MORE FREQUENTLY DURING PERIODS OF HEAVY USE.
  2. TEMPORARY CONSTRUCTION BRIDGE WILL BE MAINTAINED IN A CONDITION THAT WILL PREVENT SEDIMENT FROM ENTERING THE WATER.
  3. CLEAR EXCESSIVE SEDIMENT DEPOSITED ON BRIDGE AS NECESSARY.

7  
D02 TEMPORARY BRIDGE  
NOT TO SCALE

- Notes:**
1. Culvert Pipes may be utilized instead of footings, piers or other bridge supports.
  2. Bridge will be temporarily removed during high water events.
  3. Bridge to remain until the completion of final restoration.
  4. Filter socks shall surround the bridge structure above the water line; removed during use, and replaced at night.
  5. Ramp approaches can be either graded or dug into the ground. Stone may be used on approaches.
  6. **Winter Conditions:** When necessary, excess ice and snow should be removed from the mats to allow the equipment to have proper traction. Ensure mats are positioned and leveled to decrease the chance equipment could slide on them. Exercise Stop Work Authority if conditions are unsafe.

# **DETAIL G-4**

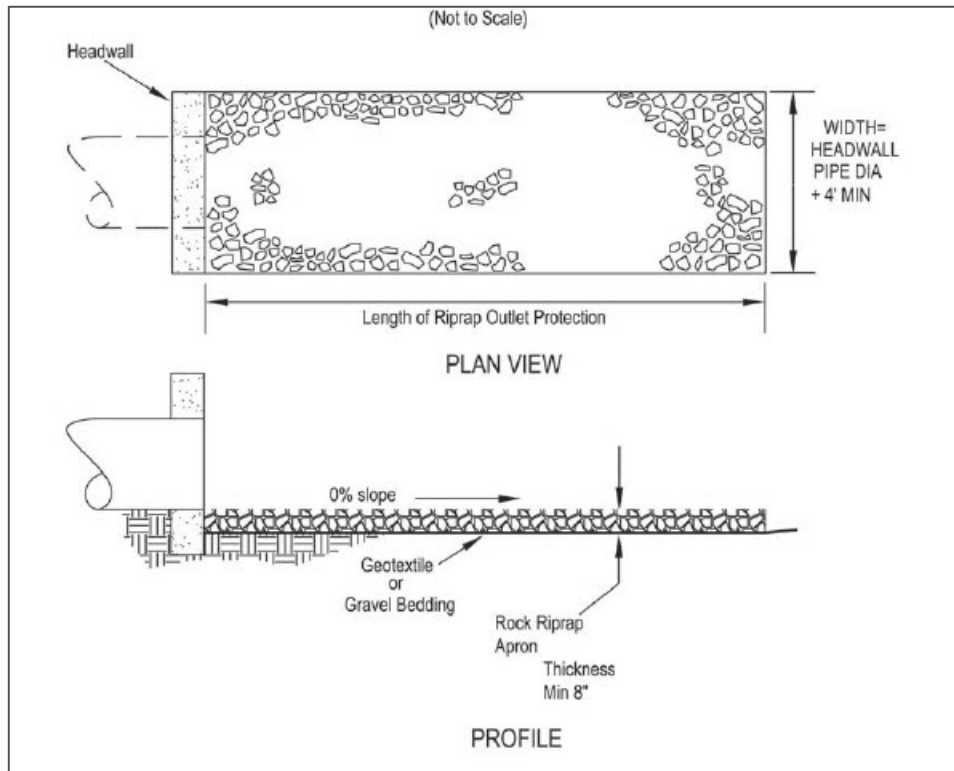
## **CULVERT (FLUMED) STREAM CROSSING**





## **DETAIL G-5**

### **ROCK OUTLET PROTECTION**

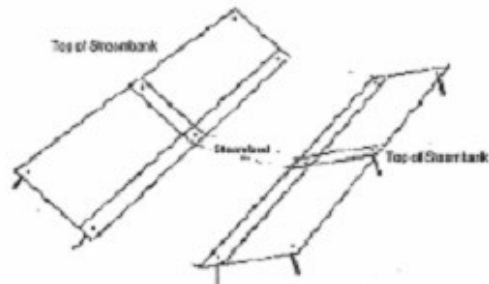


1. Subgrade for the filter or bedding and riprap shall be prepared to the required lines and grades as shown on the plan. The subgrade shall be cleared of all trees, stumps, roots, sod, loose rock, or other material.
2. Riprap shall conform to the grading limits as shown on the plan.
3. Geotextile shall be securely anchored according to manufacturers' recommendations.
4. Geotextile shall be laid with the long dimension parallel to the direction of flow and shall be laid loosely but without wrinkles and creases. Where joints are necessary, strips shall be placed to provide a 12-in. minimum overlap, with the upstream strip overlapping the downstream strip.
5. Gravel bedding shall be ODOT No. 67's or 57's unless shown differently on the drawings.
6. Riprap may be placed by equipment but shall be placed in a manner to prevent slippage or damage to the geotextile.
7. Riprap shall be placed by a method that does not cause segregation of sizes. Extensive pushing with a dozer causes segregation and shall be avoided by delivering riprap near its final location within the channel.
8. Construction shall be sequenced so that outlet protection is placed and functional when the storm drain, culvert, or open channel above it becomes operational.
9. All disturbed areas will be vegetated as soon as practical.

## **DETAIL G-6**

### **STREAM BANK RESTORATION DETAIL**

#### **Erosion Control Mat Details**



Refer to matting manufacturer's installation detail for overlap, embedment, staple patterns, and vegetative stabilization specifications

#### **Stream Rip-Rap Details**



**The following guidelines will be used to select riprap size and thickness:**

- For channels with water depth > 3 feet, use R-5 at 6" thick.
- For channels with water depth between 2 and 3 feet, use R-4 at 4" thick
- For channels with water depth between 1 and 2 feet, use R-3 at 3" thick
- For channels with water depth < 1 feet, use R-2 at 3" thick

Specifications  
for  
**Stream Utility Crossing**

---

1. When site conditions allow, one of the following shall be used to divert stream flow or keep the flow away from construction activity.
  - Drill or bore the utility lines under the stream channel.
  - Construct a cofferdam or barricade of sheet pilings, sandbags or a turbidity curtain to keep flow from moving through the disturbed area. Turbidity curtains shall be a pre-assembled system and used only parallel to flow.
  - Stage construction by confining first one-half of the channel until work there is completed and stabilized, then move to the other side to complete the crossing.
  - Route the stream flow around the work area by bridging the trench with a rigid culvert, pumping, or constructing a temporary channel. Temporary channels shall be stabilized by rock or a geotextile completely lining the channel bottom and side slopes.
2. Crossing Width -The width of clearing shall be minimized through the riparian area. The limits of disturbance shall be as narrow as possible including not only construction operations within the channel itself but also clearing done through the vegetation growing on the streambanks.
3. Clearing shall be done by cutting NOT grubbing. The roots and stumps shall be left in place to help stabilize the banks and accelerate revegetation.
4. Material excavated from the trench shall be placed at least 20 ft. from the streambanks.
5. To the extent other constraints allow, stream shall be crossed during periods of low flow.
6. Duration of Construction -The time between initial disturbance of the stream and final stabilization shall be kept to a minimum. Construction shall not begin on the crossing until the utility line is in place to within 10 ft. of the streambank.
7. Fill Placed Within the Channel -The only fill permitted in the channel should be clean aggregate, stone or rock. No soil or other fine erodible material shall be placed in the channel. This restriction includes all fill for temporary crossings, diversions, and trench backfill when placed in flowing water. If the stream flow is diverted away from construction activity the material originally excavated from the trench may be used to backfill the trench.
8. Streambank Restorations -Streambanks shall be restored to their original line and grade and stabilized with riprap or vegetative bank stabilization.
9. Runoff Control Along the Right-of-Way -To prevent sediment-laden runoff from flowing to the stream, runoff shall be diverted with water bar or swales to a sediment trapping practice a minimum of 50 ft. from the stream.
10. Sediment laden water from pumping or dewatering or pumping shall not be discharged directly to a stream. Flow shall be routed through a settling pond, dewatering sump or a flat, well-vegetated area adequate for removing sediment before the pumped water reaches the stream.
11. Dewatering operations shall not cause significant reductions in stream temperatures. If groundwater is to be discharged in high volumes during summer months, it shall first be routed through a settling pond or overland through a flat well-vegetated area.
12. Permits -In addition to these specifications, stream crossings shall conform to the rules and regulations of the U.S. Army Corps of Engineers for in-stream modifications (404 permits) and Ohio Environmental Protection Agency's State Water Quality Certification (401 permits).



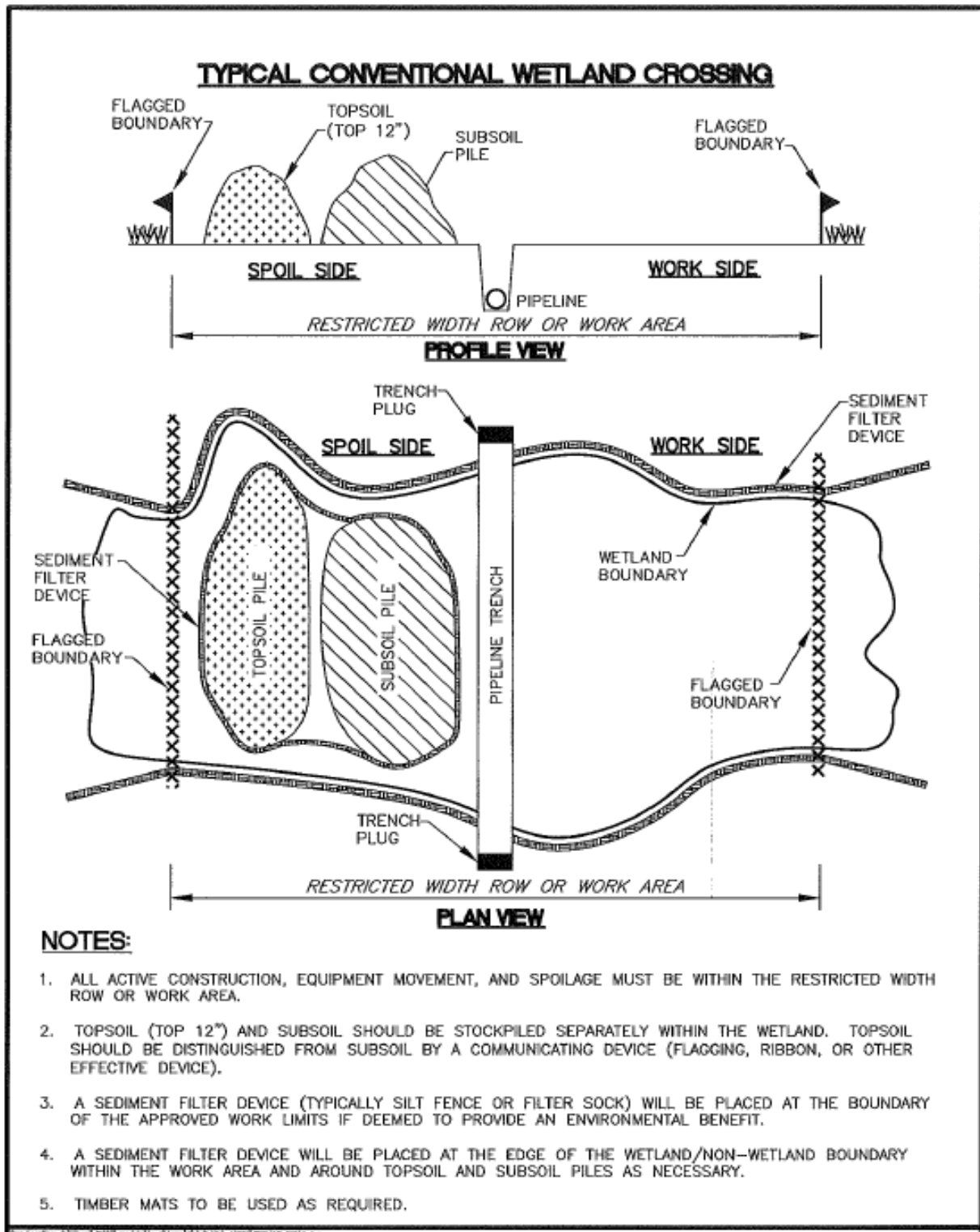
---

## **APPENDIX H**

# **Typical Wetland Crossing Drawings**

# DETAIL H-1

## TYPICAL WETLAND CROSSING



## **DETAIL H-2**

### **WETLAND TIMBER MAT CROSSING**





---

**APPENDIX I**

**NOI Application  
Documentation**



# Division of Surface Water - Notice of Intent (NOI) For Coverage Under Ohio Environmental Protection Agency General NPDES Permit

(Read accompanying instructions carefully before completing this form.)

Submission of this NOI constitutes notice that the party identified in Section I of this form intends to be authorized to discharge into state surface waters under Ohio EPA's NPDES general permit program. Becoming a permittee obligates a discharger to comply with the terms and conditions of the permit. Complete all required information as indicated by the instructions. Do not use correction fluid on this form. Forms transmitted by fax will not be accepted. A check for the proper amount must accompany this form and be made payable to "Treasurer, State of Ohio." (See the fee table in Attachment C of the NOI instructions for the appropriate processing fee.)

## I. Applicant Information/Mailing Address

**Company (Applicant) Name:** The East Ohio Gas Co d/b/a Dominion Energy Ohio

**Mailing (Applicant) Address:** 320 Springside Drive, Suite 320

**City:** Akron

**State :** OH

**Zip Code:** 44333

**Country:** USA

**Contact Person:** Greg Eastridge

**Phone:** (330) 664-2576

**Fax:**

**Contact E-mail Address:** gregory.k.eastridge@dominionenergy.com

## II. Facility/Site Location Information

**Facility/Site Name:** PIR 2788 - Apple Creek

**Facility Address:** North Hillcrest Drive

**City:** Wooster Township

**State:** OH

**Zip Code:** 44691

**County:** Wayne

**Township:** Wooster

**Facility Contact Person:** David Hollendonner

**Phone:** (330) 664-2677

**Fax:**

**Facility Contact E-mail Address:** david.hollendonner@dominionenergy.com

**Latitude:** 40.803269

**Longitude:** -81.898264

**Facility/Map Attachment**

PIR2788\_NOI\_SLM\_20240117.pdf

**Receiving Stream or MS4:** 3GQ00139\*BG, Apple Creek

## III. General Permit Information

**General Permit Number:** OHC000006

**Coverage Type:** New

**Type of Activity:** Construction Site Stormwater General Permit

**SIC Code(s):**

**Existing NPDES Facility Permit Number:** 3GC14872\*AG

**ODNR Coal Mining Application Number:**

**If Household Sewage Treatment System, is system for:**

**New Home Construction:**

**Replacement of failed existing system:**

Outfall	Design Flow (MGD):	Associated Permit Effluent Table:	Receiving Water :	Latitude	Longitude

**Are These Permits Required?**

**PTI:** NO

**Individual 401 Water Quality Certification:** NO

**Individual NPDES:** NO

**Isolated Wetland:** NO

**U.S. Army Corp Nationwide Permit:** PENDING

**Proposed Project Start Date(if applicable):** June 01, 2024

**Estimated Completion Date(if applicable):** December 31, 2024

**Total Land Disturbance (Acres):** 5.4

**MS4 Drainage Area (Sq. Miles):**

**SWP3 Attachment(s):** <None>

## IV. Payment Information

**Check #:**

**For Ohio EPA Use Only**

**Check Amount:**

**Check ID(OFA):** \_\_\_\_\_

**ORG #:** \_\_\_\_\_

**Date of Check:**

**Rev ID:** \_\_\_\_\_

**DOC #:** \_\_\_\_\_

I certify under penalty of law that this document and all attachments were prepared under my direction or supervision in accordance with a system designed to assure that qualified personnel properly gather and evaluate the information submitted. Based on my inquiry of the person or persons who manage the system, or those persons directly responsible for gathering the information, the information submitted is, to the best of my knowledge and belief, true, accurate and complete. I am aware that there are significant penalties for submitting false information, including the possibility of fine and imprisonment for knowing violations.

**Applicant Name (printed or typed):**

**Title:**

**Signature:**

**Date:**


## ADDITIONAL INFORMATION

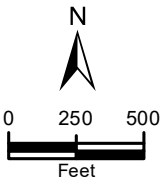
*Please add any additional comments or attachments below.*



Project Name: PIR 2788 – Apple Creek  
Facility Contact: David Hollendonner



 Project Study Area



**Figure 1**  
**Site Location Map**

PIR 2788 - Apple Creek  
Dominion Energy Ohio  
Wayne County, Ohio  
Date: 1/17/2024



---

**APPENDIX J**

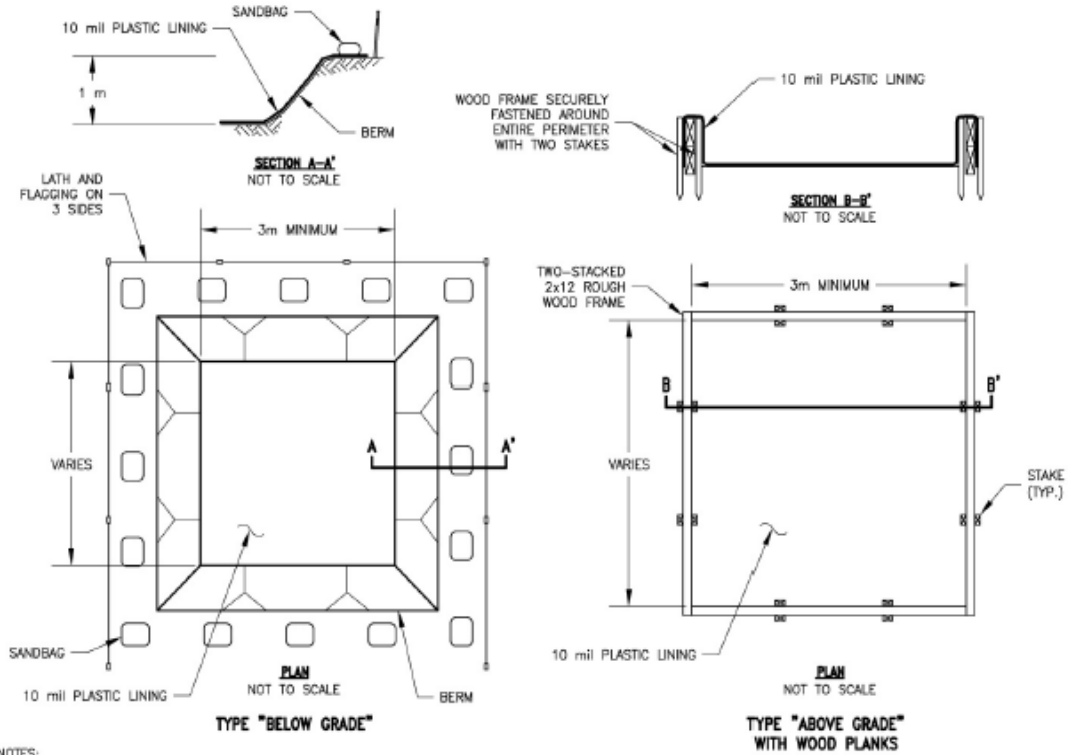
**Concrete Washout Typical  
Detail**

# DETAIL J-1

## Concrete Washout Detail\*

Note: This detail to be used in the absence of the following concrete washout BMPs:

1. Washout into a depressional area where new sidewalks will be poured.
2. Washout into a lined pit in the ground with filter socks as perimeter control.



**NOTES:**

1. ACTUAL LAYOUT DETERMINED IN THE FIELD.
2. THE CONCRETE WASHOUT SIGN (SEE PAGE 6) SHALL BE INSTALLED WITHIN 10 m. OF THE TEMPORARY CONCRETE WASH-OUT FACILITY.



Sign Examples



Photograph of the "ABOVE GRADE" concrete washout structure

- \* 1. Concrete washout location is subject to change and will be located by the contractor before construction begins.
2. Concrete washout will be installed away from wetlands and streams.
3. Proper removal and disposal of concrete washout material is required once the project is complete.



---

## **APPENDIX K**

### **SWP3 Inspection Forms**

## ECTS Checklist Guidance

---

### Checklist Title: SWP3 Inspection Form

#### (For Dominion Energy Construction Projects with a SWP3)

THIS CHECKLIST IS TO BE COMPLETED BY AN ENVIRONMENTAL INSPECTOR (EI) CONTRACTED BY DOMINION ENERGY OR A DOMINION ENERGY INSPECTOR DURING SCHEDULED OR UNSCHEDULED SITE INSPECTIONS OF ACTIVE CONSTRUCTION SITES WITH A SWP3.

- **Information at the top of the form.**

- **Site Name:** Note the Project name and/or location of the construction activity.
- **Inspector:** Note the inspector’s name and circle the appropriate title.
- **Qualifications:** Note applicable qualifications.
  - Eight-Hour Stormwater Management During Construction Course - A course administered by numerous third-party trainers.
  - CESSWI - Certified Erosion, Sediment and Stormwater Inspector. A federal certification program administered by EnviroCert International. If “Yes” include certification number.
  - Dominion SWP3 Training - A training module prepared by Dominion Energy Environment and Sustainability for Dominion Energy construction Sites
  - Other – List other applicable qualifications
- **Signature:** Include the signature of the inspector on paper copy maintained at the site.

- **Inspection Documentation Area:**

- **Circle the applicable inspection type:**
  - “Weekly” - Inspection required at least once every seven calendar days during active construction and restoration.
  - “Monthly” - Inspection required after all construction and restoration activity has ceased.
  - “Routine” - Minimum weekly inspection interval
  - “Precipitation Event” - Must be completed at least once every seven (7) calendar days and after any storm event greater than one-half inch of rain per 24-hour period by the end of the next calendar day, excluding weekends and holidays, unless work is scheduled. Rainfall amounts will be determined by Dominion Energy personnel or a designated representative using National Weather Service or other acceptable resources such as an on-site rain gauge.
  - “Other” - Random inspection, Compliance Inspection, Follow-up, etc.
- **Has it rained since last inspection? (Y/N)** Circle as appropriate and note the time started and duration of the previous storm event. If the precipitation amount is known, insert this information here.
- **Current Conditions:** Describe the weather conditions during this inspection. Circle the most appropriate soil condition. “Saturated” = standing water is visible on the ground surface.
- **Features Inspected:** List each feature inspected at the site. The Feature ID must correspond to the site plan submitted with the SWP3 or E&S Control Plan. Record any repairs or maintenance necessary for each device; include an accurate description of the

location of repair and a date when the repair must be completed.

- **Information on second page.**

- **Construction Inspector(s):** Note the inspection date, site name, and inspector's name.
- **Previous Inspections:** Review the previous site inspection form, including action items and dates of completion. Comment on any ongoing activities and its progress. The site has three days from discovery to complete applicable repairs and 10 days from discovery to install new controls if warranted.
- **Necessary Documents:** Confirm the presence of environmental permit, plans, and notices. These must include: a Stormwater Pollution Prevention Plan (SWP3) or Erosion and Sediment (E&S) Control Plan; Construction Permit/Land Disturbance Permit; Notice of Intent (NOI) to begin disturbance; and Notices of Termination.
- **Disturbed Areas:** Any disturbed areas that are anticipated to lie dormant for more than 14 days must be stabilized to prevent potential erosion. Stabilization may include: permanent cover (e.g., building, parking lot, etc.); vegetation (seed and straw), mulch or tack; gravel, stone or rip rap.
- **E/SCDs:** Are Erosion/Sediment Control Devices (E/SCDs) of appropriate design for the areas they are controlling, properly installed and being maintained? The E/SCDs installed must be described in the SWP3 or E&S Control Plan. Furthermore, design details must meet the minimum design details described in the state stormwater control manual. If alternate control methods were installed: notify the site manager and engineer to confirm the controls installed are sufficiently designed; revise the plans accordingly; or remove and replace insufficient controls. The site has three days from discovery to complete applicable repairs and 10 days from discovery to install new controls if warranted.
- **Final Grade:** List any areas at final grade since last inspection. Areas at final grade are not likely to be disturbed again and must be stabilized. See Question # 9 above.
- **Untreated Discharges:** Observations of untreated discharge may include:
  - A sheen indicating petroleum products;
  - Foam or froth indicating a chemical or other discharge;
  - Suspended particles or sludge beneath the surface;
  - Discolored water, including dirty/muddy characteristics of sedimentation;
  - A change in water temperature; and
  - Damaged or stressed vegetation or wildlife.
- **Notification:** Review the inspection findings with a site manager or other responsible person and note this individual.

Checklist Owner: Tara Buzzelli

Local: 8-657-2579

Work: 330-664-2579

Cell: 330-604-8871

Email: Tara.E.Buzzelli@DominionEnergy.com

Email: Gregory.K.Eastridge@DominionEnergy.com

Date of Last Revision: July 2020

Subject Matter Expert: Greg Eastridge

Local: 8-657-2576

Work: 330-664-2576

Cell: 330-571-7855



## OHIO SWP3 INSPECTION FORM

Site Name: \_\_\_\_\_

Date: \_\_\_\_\_

Environmental Inspection Company: \_\_\_\_\_

Environmental Inspector: \_\_\_\_\_

Qualifications: Completed 8-HR Stormwater Management During Construction Course	Y	N
CESSWI	Y	N
Dominion SWP3 Training	Y	N
Other: _____		

Inspector Signature: \_\_\_\_\_

**Weekly**

**Monthly**

**Routine Inspection**

**Precipitation Event >0.5-inch**

**Other** \_\_\_\_\_

*(circle all applicable)*

**Has it rained since last inspection?** *(circle one)*

**Yes: Date(s) & Approx. Amount** \_\_\_\_\_

**No**

**Current Conditions:** \_\_\_\_\_

**Soil Conditions:**

**Dry**

**Wet**

**Saturated**

**Frozen**

*(circle applicable conditions)*

**Feature ID**

**BMP, ECD, SCD Applied**

**Recommendations**

Feature ID	BMP, ECD, SCD Applied	Recommendations

BMP: Best Management Practice E/SCD: Erosion/Sediment Control Device SF: Silt Fence SW: Straw Wattle W: Wetland S: Stream  
 TM: Timber Mat IP: Inlet Protection WB: Waterbar RCE: Rock Construction Entrance ECM: Erosion Control Matting FS: Filter Sock

Date:

Site:

---

**Stormwater Pollution Prevention Plan Inspection Form**

---

**Construction Inspector(s) On Site:**

---

**Unresolved issues from previous inspections:**

---

**Are the SWP3, NOI and General Permit Letter on-site?      Yes      No**  
**If no, explain.**

---

**List newly disturbed areas likely to lie dormant for more than 14 days:**

---

**Have soil stockpiles been placed at least 50 feet from drainageways?**

---

**List construction entrances and SCDs used to prevent tracking into roadway:**

---

**Are E/SCDs of appropriate design for area they are controlling, properly installed and being maintained?**

---

**List any new areas at final grade since last inspection:**

---

**Is the inlet protection of appropriate design?**

---

**Were any untreated discharges into streams, wetlands or inlets observed? If yes, document location(s):**

---

**Note person(s) notified of any inspection finding(s) and expected date of correction:**

---

**Notes**

---

**APPENDIX L**

**Seeding Specifications**



# APPENDIX L-1

Specifications  
for

## Temporary Seeding

Table 7.8.1 Temporary Seeding Species Selection

Seeding Dates	Species	Lb./1000 ft2	Lb/Acre
March 1 to August 15	Oats	3	128 (4 Bushel)
	Tall Fescue	1	40
	Annual Ryegrass	1	40
	Perennial Ryegrass	1	40
	Tall Fescue	1	40
	Annual Ryegrass	1	40
	Annual Ryegrass	1.25	55
	Perennial Ryegrass	3.25	142
	Creeping Red Fescue	0.4	17
	Kentucky Bluegrass	0.4	17
August 16th to November	Oats	3	128 (3 bushel)
	Tall Fescue	1	40
	Annual Ryegrass	1	40
August 16th to November	Rye	3	112 (2 bushel)
	Tall Fescue	1	40
	Annual Ryegrass	1	40
	Wheat	3	120 (2 bushel)
	Tall Fescue	1	40
	Annual Ryegrass	1	40
	Perennial Rye	1	40
	Tall Fescue	1	40
	Annual Ryegrass	1	40
	Annual Ryegrass	1.25	40
Perennial Ryegrass	3.25	40	
Creeping Red Fescue	0.4	40	
Kentucky Bluegrass	0.4	40	
November 1 to Feb. 29	Use mulch only or dormant seeding		

Note: Other approved species may be substituted.

- Structural erosion and sediment control practices such as diversions and sediment traps shall be installed and stabilized with temporary seeding prior to grading the rest of the construction site.
- Temporary seed shall be applied between construction operations on soil that will not be graded or reworked for 21 days or greater. These idle areas shall be seeded within 7 days after grading.
- The seedbed should be pulverized and loose to ensure the success of establishing vegetation. Temporary seeding should not be postponed if ideal seedbed preparation is not possible.
- Soil Amendments—Temporary vegetation seeding rates shall establish adequate stands of vegetation, which may require the use of soil amendments. Base rates for lime and fertilizer shall be used.
- Seeding Method—Seed shall be applied uniformly with a cyclone spreader, drill, cultipacker seeder, or hydroseeder. When feasible, seed that has been broadcast shall be covered by raking or dragging and then lightly tamped into place using a roller or cultipacker. If hydroseeding is used, the seed and fertilizer will be mixed on-site and the seeding shall be done immediately and without interruption.

Specifications  
for  
**Temporary Seeding**

---

### Mulching Temporary Seeding

1. Applications of temporary seeding shall include mulch, which shall be applied during or immediately after seeding. Seedings made during optimum seeding dates on favorable, very flat soil conditions may not need mulch to achieve adequate stabilization.
2. Materials:
  - Straw—If straw is used, it shall be unrotted small-grain straw applied at a rate of 2 tons per acre or 90 lbs./ 1,000 sq. ft. (2-3 bales)
  - Hydroseeders—If wood cellulose fiber is used, it shall be used at 2000 lbs./ ac. or 46 lb./ 1,000-sq.-ft.
  - Other—Other acceptable mulches include mulch mattings applied according to manufacturer's recommendations or wood chips applied at 6 ton/ ac.
3. Straw Mulch shall be anchored immediately to minimize loss by wind or water. Anchoring methods:
  - Mechanical—A disk, crimper, or similar type tool shall be set straight to punch or anchor the mulch material into the soil. Straw mechanically anchored shall not be finely chopped but left to a length of approximately 6 inches.
  - Mulch Netting—Netting shall be used according to the manufacturers recommendations. Netting may be necessary to hold mulch in place in areas of concentrated runoff and on critical slopes.
  - Synthetic Binders—Synthetic binders such as Acrylic DLR (Agri-Tac), DCA-70, Petroset, Terra Track or equivalent may be used at rates recommended by the manufacturer.
  - Wood-Cellulose Fiber—Wood-cellulose fiber binder shall be applied at a net dry wt. of 750 lb./ac. The wood-cellulose fiber shall be mixed with water and the mixture shall contain a maximum of 50 lb. / 100 gal.

# APPENDIX L-2

Specifications  
for

## Permanent Seeding

---

### Site Preparation

1. Subsoiler, plow, or other implement shall be used to reduce soil compaction and allow maximum infiltration. (Maximizing infiltration will help control both runoff rate and water quality.) Subsoiling should be done when the soil moisture is low enough to allow the soil to crack or fracture. Subsoiling shall not be done on slip-prone areas where soil preparation should be limited to what is necessary for establishing vegetation.
2. The site shall be graded as needed to permit the use of conventional equipment for seedbed preparation and seeding.
3. Topsoil shall be applied where needed to establish vegetation.

### Seedbed Preparation

1. Lime—Agricultural ground limestone shall be applied to acid soil as recommended by a soil test. In lieu of a soil test, lime shall be applied at the rate of 100 pounds per 1,000-sq. ft. or 2 tons per acre.
2. Fertilizer—Fertilizer shall be applied as recommended by a soil test. In place of a soil test, fertilizer shall be applied at a rate of 25 pounds per 1,000-sq. ft. or 1000 pounds per acre of a 10-10-10 or 12-12-12 analyses.
3. The lime and fertilizer shall be worked into the soil with a disk harrow, spring-tooth harrow, or other suitable field implement to a depth of 3 inches. On sloping land, the soil shall be worked on the contour.

### Seeding Dates and Soil Conditions

Seeding should be done March 1 to May 31 or August 1 to September 30. If seeding occurs outside of the above-specified dates, additional mulch and irrigation may be required to ensure a minimum of 80% germination. Tillage for seedbed preparation should be done when the soil is dry enough to crumble and not form ribbons when compressed by hand. For winter seeding, see the following section on dormant seeding.

### Dormant Seedings

1. Seedings should not be made from October 1 through November 20. During this period, the seeds are likely to germinate but probably will not be able to survive the winter.
2. The following methods may be used for "Dormant Seeding":

- From October 1 through November 20, prepare the seedbed, add the required amounts of lime and fertilizer, then mulch and anchor. After November 20, and before March 15, broadcast the selected seed mixture. Increase the seeding rates by 50% for this type of seeding.
- From November 20 through March 15, when soil conditions permit, prepare the seedbed, lime and fertilize, apply the selected seed mixture, mulch and anchor. Increase the seeding rates by 50% for this type of seeding.
- Apply seed uniformly with a cyclone seeder, drill, cultipacker seeder, or hydro-seeder (slurry may include seed and fertilizer) on a firm, moist seedbed.
- Where feasible, except when a cultipacker type seeder is used, the seedbed should be firmed following seeding operations with a cultipacker, roller, or light drag. On sloping land, seeding operations should be on the contour where feasible.

### Mulching

1. Mulch material shall be applied immediately after seeding. Dormant seeding shall be mulched. 100% of the ground surface shall be covered with an approved material.
2. Materials
  - Straw—If straw is used it shall be unrotted small-grain straw applied at the rate of 2 tons per acre or 90 pounds (two to three bales) per 1,000-sq. ft. The mulch shall be spread uniformly by hand or mechanically applied so the soil surface is covered. For uniform distribution of hand-spread mulch, divide area into approximately 1,000-sq.-ft. sections and spread two 45-lb. bales of straw in each section.
  - Hydroseeders—If wood cellulose fiber is used, it shall be applied at 2,000 lb./ac. or 46 lb./1,000 sq. ft.
  - Other—Other acceptable mulches include rolled erosion control matings or blankets applied according to manufacturer's recommendations or wood chips applied at 6 tons per acre.



### 3. Straw and Mulch Anchoring Methods

Straw mulch shall be anchored immediately to minimize loss by wind or water.

- **Mechanical**—A disk, crimper, or similar type tool shall be set straight to punch or anchor the mulch material into the soil. Straw mechanically anchored shall not be finely chopped but, generally, be left longer than 6 inches.
- **Mulch Netting**—Netting shall be used according to the manufacturer's recommendations. Netting may be necessary to hold mulch in place in areas of concentrated runoff and on critical slopes.
- **Asphalt Emulsion**—Asphalt shall be applied as recommended by the manufacture or at the rate of 160 gallons per acre.

- **Synthetic Binders**—Synthetic binders such as Acrylic DLR (Agri-Tac), DCA-70, Petroset, Terra Tack or equivalent may be used at rates specified by the manufacturer.
- **Wood Cellulose Fiber**—Wood cellulose fiber shall be applied at a net dry weight of 750 pounds per acre. The wood cellulose fiber shall be mixed with water with the mixture containing a maximum of 50 pounds cellulose per 100 gallons of water.

#### Irrigation

Permanent seeding shall include irrigation to establish vegetation during dry weather or on adverse site conditions, which require adequate moisture for seed germination and plant growth.

Irrigation rates shall be monitored to prevent erosion and damage to seeded areas from excessive runoff.

**Table 7.10.2 Permanent Seeding**

Seed Mix	Seeding Rate		Notes:
	Lbs./acre	Lbs./1,000 Sq. Feet	
<b>General Use</b>			
Creeping Red Fescue	20-40	1/2-1	For close mowing & for waterways with <2.0 ft/sec velocity
Domestic Ryegrass	10-20	1/4-1/2	
Kentucky Bluegrass	20-40	1/2-1	
Tall Fescue	40-50	1-1 1/4	
Turf-type (dwarf) Fescue	90	2 1/4	
<b>Steep Banks or Cut Slopes</b>			
Tall Fescue	40-50	1-1 1/4	
Crown Vetch	10-20	1/4-1/2	Do not seed later than August
Tall Fescue	20-30	1/2-3/4	
Flat Pea	20-25	1/2-3/4	Do not seed later than August
Tall Fescue	20-30	1/2-3/4	
<b>Road Ditches and Swales</b>			
Tall Fescue	40-50	1-1 1/4	
Turf-type (Dwarf) Fescue	90	2 1/4	
Kentucky Bluegrass	5	0.1	
<b>Lawns</b>			
Kentucky Bluegrass	100-120	2	
Perennial Ryegrass		2	
Kentucky Bluegrass	100-120	2	For shaded areas
Creeping Red Fescue		1-1/2	

Note: Other approved seed species may be substituted.

---

## **APPENDIX M**

### **Pre-Construction and Post- Construction Runoff Volumes & Peak Rate Calculations**

**Final Volume Calculations**

*(SCS Curve Number Method)*

<b>Parameter</b>	<b>Drainage Area</b>	<b>Proposed Change Area</b>	<b>Notes</b>
Curve Number, CN	83.1	89	<i>Refer "CurveNumber" worksheet for CN values for "Drainage Area"</i>
Precipitation, P (in)	4.42	4.42	<i>25-year 24hr precipitation (Refer "CriticalStorm" worksheet)</i>
Drainage Area (ac)	21472.3	0.220	
Potential maximum retention after runoff begins, S (in)	2.03	1.24	
Runoff (in)	2.66	3.22	
Runoff (ft3)	<b><u>2.08E+08</u></b>	<b><u>2570.9</u></b>	

**Final Peak Runoff Calculations**

*(Rational Method)*

<b>Parameter</b>	<b>Drainage Area</b>	<b>Proposed Change Area</b>	
Runoff Coefficient, C	NA	0.7	<i>Estimated Based on Landuse as per Ohio's Rainwater and Land Development Standards document</i>
Time of concentration, Tc (hours)	NA	0.4	<i>Estimated using TR55</i>
Rainfall Intensity, i (in/hr)	NA	1.16	<i>Estimated based on Tc as per Ohio's Rainwater and Land Development Standards</i>
Peak Flow Rate, Qp (cfs)	<b><u>4380.0</u></b>	<b><u>0.179</u></b>	



***PRE-DEVELOPMENT***

**Parameter**

Curve Number, CN	76
Precipitation, P (in)	2.06 1-year 24hr precipitation
Drainage Area (ac)	0.220
Potential maximum retention after runoff begins, S (in)	3.16
Runoff (in)	0.44
Runoff (ft3)	355.3

**Proposed Change Area**

***POST-DEVELOPMENT***

**Parameter**

Curve Number, CN	89
Precipitation, P (in)	2.06 1-year 24hr precipitation
Drainage Area (ac)	0.220
Potential maximum retention after runoff begins, S (in)	1.24
Runoff (in)	1.08
Runoff (ft3)	860.8

**Proposed Change Area**

142%

**Critical Storm**

**25-Year**

Based on Ohio's "Rainwater and Land Development Standards" document if post-development 1-Year runoff volume is more than by 100% to 250% of pre-development 1-year runoff volume, 25-year storm is the critical storm to be considered to fulfill water quality standards.

*Areas (acres) of each combination of soil hydrologic group and land use*

LanduseCode	---	A	B	B/D	C	C/D	D	Grand Total	Landuse Name
11	3.06		0.33	0.84	1.68	5.72	5.05	16.68	Openwater
21	0.81	3.43	52.25	21.04	328.04	550.21	74.00	1029.78	Developed Open
22	2.41	2.91	49.78	18.03	390.17	621.42	92.70	1177.42	Developed Low
23	1.32	1.43	19.95	5.88	166.42	305.85	32.76	533.62	Developed Medium
24	8.25	0.22	5.25	0.50	50.98	132.24	13.45	210.89	Developed High
31	0.38		0.28		2.50	11.62	3.76	18.54	Barren
41	0.47	45.39	445.04	257.79	769.65	969.06	238.15	2725.56	Forest
42			20.26		38.27	22.49	1.93	82.95	Forest
43	0.25	2.18	35.72	18.08	130.81	116.03	22.07	325.15	Forest
52		0.67	0.05	0.11	3.81	5.80	10.69	21.13	Shrub
71		1.11	2.10	0.33	11.07	16.99	4.28	35.88	Grass
81	14.58	9.98	317.73	311.60	2079.85	3289.72	485.22	6508.68	Pasture
82	15.80	18.55	178.75	308.64	1844.30	5223.13	1045.66	8634.84	Crop
90		5.52	0.08	11.56	16.91	57.88	2.10	94.06	Wetland
95				0.63	0.26			0.89	Wetland

**21416.04**

*Curve Number for each combination of soil hydrologic group and land use*

LanduseCode								
11	100.00	100.00	100.00	100.00	100.00	100.00	100.00	100.00
21	84.00	49.00	69.00	84.00	79.00	84.00	84.00	84.00
22	82.00	46.00	65.00	82.00	77.00	82.00	82.00	82.00
23	86.00	57.00	72.00	86.00	81.00	86.00	86.00	86.00
24	92.00	77.00	85.00	92.00	90.00	92.00	92.00	92.00
31	94.00	77.00	86.00	94.00	91.00	94.00	94.00	94.00
41	79.00	36.00	60.00	79.00	73.00	79.00	79.00	79.00
42	79.00	36.00	60.00	79.00	73.00	79.00	79.00	79.00
43	79.00	36.00	60.00	79.00	73.00	79.00	79.00	79.00
52	79.00	36.00	60.00	79.00	73.00	79.00	79.00	79.00
71	84.00	49.00	69.00	84.00	79.00	84.00	84.00	84.00
81	84.00	49.00	69.00	84.00	79.00	84.00	84.00	84.00
82	89.00	67.00	78.00	89.00	85.00	89.00	89.00	89.00
90	100.00	100.00	100.00	100.00	100.00	100.00	100.00	100.00
95	100.00	100.00	100.00	100.00	100.00	100.00	100.00	100.00

*Curve Number contribution of each combination of soil hydrologic group and land use*

LanduseCode								
11	0.01	0.00	0.00	0.00	0.01	0.03	0.02	
21	0.00	0.01	0.17	0.08	1.21	2.16	0.29	
22	0.01	0.01	0.15	0.07	1.40	2.38	0.35	
23	0.01	0.00	0.07	0.02	0.63	1.23	0.13	
24	0.04	0.00	0.02	0.00	0.21	0.57	0.06	
31	0.00	0.00	0.00	0.00	0.01	0.05	0.02	
41	0.00	0.08	1.25	0.95	2.62	3.57	0.88	
42	0.00	0.00	0.06	0.00	0.13	0.08	0.01	
43	0.00	0.00	0.10	0.07	0.45	0.43	0.08	
52	0.00	0.00	0.00	0.00	0.01	0.02	0.04	
71	0.00	0.00	0.01	0.00	0.04	0.07	0.02	
81	0.06	0.02	1.02	1.22	7.67	12.90	1.90	
82	0.07	0.06	0.65	1.28	7.32	21.71	4.35	
90	0.00	0.03	0.00	0.05	0.08	0.27	0.01	
95	0.00	0.00	0.00	0.00	0.00	0.00	0.00	

**83.1** Total weighted curve number for the drainage area

**ATTACHMENT G**  
**SUMMIT COUNTY SOIL & WATER CONSERVATION DISTRICT**  
**COORDINATION**



February 26, 2024

**BY UPS**

Rob Kastner  
Wayne Soil & Water Conservation District  
428 West Liberty Street  
Wooster, Ohio 44691

**RE: The East Ohio Gas Company, Pipeline Infrastructure Replacement Program  
Wayne County Stormwater Management Plan Review Application and  
Application for Work in Floodplain  
PIR 2788 – Apple Creek**

Dear Mr. Kastner:

The East Ohio Gas Company, d/b/a Dominion Energy Ohio (DEO), requests review of the following information associated with the Pipeline Infrastructure Replacement (PIR) project, PIR 2788 – Apple Creek. DEO is proposing to replace natural gas pipeline under the PIR Program. The purpose of the program is to replace existing pipe to ensure the safety and reliability of pipeline operations.

The PIR 2788 Project is located within Wooster Township, Wayne County approximately 40 feet from the edge of pavement along N. Hillcrest Drive as well as an existing sixty (60)-ft wide utility easement which originates at N. Hillcrest Drive and extends northeast to S. Geyers Chapel Road, and a newly acquired sixty (60)-foot wide easement which originates as a private drive on the east side of N. Hillcrest Drive and extends east to Apple Creek. The following documents are enclosed for review:

- PIR 2788 Stormwater Pollution Prevention Plan (SWPPP) (Attachment 1)
- Wayne County Construction Application (CAP) Permit (Attachment 2)
- Wayne County Floodplain Development Permit Application, “No – Impact” Floodway Certification, and Construction Drawings (Attachment 3)
- Ohio EPA General Permit OHC000006 NOI Documentation (Attachment 4)
- A check for \$600 made payable to Wayne County Commissioners (CAP fee)
- A check for \$200 made payable to Wayne County Planning Department (Floodplain Fee)

The Ohio EPA construction storm water permit documentation included as Attachment 4 was generated from the online permit submission site. DEO anticipates submitting the online permit request to the Agency in the near future. The issued Ohio EPA construction storm water permit will be forwarded to your attention upon receipt.

The United States Army Corps of Engineers is currently reviewing the project. The issued Nationwide Permit #12 Authorization will be provided upon receipt.

DEO will hold a pre-construction meeting with the Wayne County Soil and Water Conservation District (SWCD) inspector prior to earthwork activities. This meeting will be scheduled by DEO with Wayne SWCD office personnel, DEO, the contractor, and the DEO environmental inspector.

Review and approval of this project is appreciated. Please forward responses to the attention of:

Greg Eastridge  
Environmental Specialist III  
320 Springside Drive, Suite 320  
Akron, Ohio 44333  
gregory.k.eastridge@dominionenergy.com

If you have any questions, please contact Greg Eastridge at (330) 664-2576.

Sincerely,



Darrell R. Shier  
Authorized Representative  
Manager Environmental Services

Enclosures

cc: Greg Eastridge  
Administrator, Wayne County MS4 (one [1] copy of the SWPPP)

CHERYL GOLDEN  
1001 DOM ENERGY FLEX  
DOMINION ENERGY  
320 SPRINGSIDE DR  
AKRON OH 44333

Commercial Convenience Check 284

1/31/2024 68-1/510  
Date

Pay to the order of WAYNE COUNTY PLANNING DEPT \$ 200<sup>00</sup>  
two hundred and <sup>xx</sup>/100 Dollars

Security Features Details on Back

Bank of America Bank of America, N.A. Richmond, VA  
MWO 63449624

Void after 60 days  
For Deposit Only

For PIR 2788 APPLE CREEK

*[Signature]* MP

⑆051000017100551102664891⑆0284

Harland Clarke

CHERYL GOLDEN  
1001 DOM ENERGY FLEX  
DOMINION ENERGY  
320 SPRINGSIDE DR  
AKRON OH 44333

Commercial Convenience Check 285

1/30/2024 68-1/510  
Date

Pay to the order of WAYNE COUNTY COMMISSIONERS DEPT \$ 600<sup>00</sup>  
six hundred and <sup>xx</sup>/100 Dollars

Security Features Details on Back

Bank of America Bank of America, N.A. Richmond, VA  
MWO 63449624

Void after 60 days  
For Deposit Only

For PIR 2788 APPLE CREEK

*[Signature]* MP

⑆051000017100551102664891⑆0285

Harland Clarke



**Attachment 1**

**PIR 2788 Stormwater Pollution Prevention Plan (SWPPP)**



**OHIO GENERAL PERMIT AUTHORIZATION FOR STORMWATER  
DISCHARGES ASSOCIATED WITH CONSTRUCTION ACTIVITY UNDER  
THE NATIONAL POLLUTANT DISCHARGE ELIMINATION SYSTEM (NPDES)**

**The East Ohio Gas Company, d/b/a Dominion Energy Ohio  
Stormwater Pollution Prevention Plan (SWP3)**

**PIR 2788 – Apple Creek  
Wooster Township, Wayne County, Ohio**

**Planned Construction Start Date: June 2024**

**Planned Construction Completion Date: December 2024**

**Construction Supervisor: \_\_\_\_\_**

**Telephone: \_\_\_\_\_**

**Project Manager (signature): \_\_\_\_\_**

**Construction Contractor (signature): \_\_\_\_\_**

**Environmental Inspector (signature): \_\_\_\_\_**

**Note:**

**THIS PLAN MUST BE KEPT AT THE  
CONSTRUCTION SITE DURING WORKING HOURS**

**SWP3 Prepared: February 22, 2024**

**Prepared by: Environmental Consulting & Technology, Inc.**


DULY AUTHORIZED

**OPERATOR/PERMITEE CERTIFICATION**

I certify that the positions named below are my duly authorized representatives for the Ohio EPA General Construction Stormwater Permits (Ohio NPDES General Permit OHC000006 or General Permit for Storm Water Discharges Associated with Construction Activity from Oil and Gas Linear Transmission Line and Gathering Line Installation OHCG00001) for Discharges of Stormwater from Construction Activities. I certify that these positions named below and defined within the corresponding SWPPP are my duly authorized representatives to have overall responsibilities sufficient to implement the SWPPP, amend or modify the SWPPP, and sign all required reports as assigned.

I also certify that the positions named below are my duly authorized representatives for the Ohio EPA General Permit Authorization to Discharge Hydrostatic Test Water (Ohio NPDES General Permit OHH000004). These individuals are my duly authorized representatives to sign all required reports or other information that may be requested by the Ohio EPA Director.

“Facilities Project Manager, Owner  
Project Engineer  
Environmental Compliance Coordinator  
Supervisor Environmental  
Qualified Inspection Personnel”

Signature   
Printed Name Zachary R. Goodson  
Title Director - Gas operations  
Date 5-4-2023

This Operator Certification must be signed by a responsible corporate officer or delegated authority.



DULY AUTHORIZED

**OPERATOR/PERMITEE CERTIFICATION**

I certify that the positions named below are my duly authorized representatives for the Ohio EPA General Construction Stormwater Permits (Ohio NPDES General Permit OHC000006 or General Permit for Storm Water Discharges Associated with Construction Activity from Oil and Gas Linear Transmission Line and Gathering Line Installation OHCG00001) for Discharges of Stormwater from Construction Activities. I certify that these positions named below and defined within the corresponding SWPPP are my duly authorized representatives to have overall responsibilities sufficient to implement the SWPPP, amend or modify the SWPPP, and sign all required reports as assigned.

I also certify that the positions named below are my duly authorized representatives for the Ohio EPA General Permit Authorization to Discharge Hydrostatic Test Water (Ohio NPDES General Permit OHH000004). These individuals are my duly authorized representatives to sign all required reports or other information that may be requested by the Ohio EPA Director.

“Facilities Project Manager, Owner  
Project Engineer  
Environmental Compliance Coordinator  
Supervisor Environmental  
Qualified Inspection Personnel”

Signature George K. Smith  
Printed Name George K. Smith  
Title Director Gas Operations  
Date 5-10-23

This Operator Certification must be signed by a responsible corporate officer or delegated authority.

**CERTIFICATIONS**

*Owner/Developer Certification (must be signed by president, vice-president or equivalent or ranking elected official)*

I certify under penalty of law that this document and all attachments were prepared under my direction or supervision in accordance with a system designed to assure that qualified personnel properly gathered and evaluated the information submitted. Based on my inquiry of the person or persons who manage the system or those persons directly responsible for gathering the information, the information submitted is, to the best of my knowledge and belief, true, accurate and complete. I am aware that there are significant penalties for submitting false information, including the possibility of fine and imprisonment for knowing violations.

\_\_\_\_\_  
Signature

\_\_\_\_\_  
Date

\_\_\_\_\_  
Printed Name

\_\_\_\_\_  
Title

*If authorization is no longer accurate because of a different individual or position has responsibility for the overall operation of the Project, a new authorization must be submitted to the Director prior to, or together with any reports, information, or applications to be signed by an authorized representative.*

*Contractor(s) Certification (must be signed by president, vice-president or equivalent or ranking elected official)*

I certify under penalty of law that I have reviewed this document, any attachments, and the SWP3 referenced above. Based on my inquiry of the construction site owner/developer identified above, and/or my inquiry of the person directly responsible for assembling this SWP3, I believe the information submitted is accurate. I am aware that this SWP3, if approved, makes the above-described construction activity subject to the Ohio NPDES General Permit, and that certain activities on-site are thereby regulated. I am aware that there are significant penalties, including the possibility of fine and imprisonment for knowing violations and for failure to comply with these permit requirements.

\_\_\_\_\_  
Primary Contractor Name

\_\_\_\_\_  
\_\_\_\_\_  
Primary Contractor Address

\_\_\_\_\_  
Signature

\_\_\_\_\_  
Date

\_\_\_\_\_  
Printed Name

\_\_\_\_\_  
Title

\_\_\_\_\_  
Subcontractor Name

\_\_\_\_\_  
\_\_\_\_\_  
Subcontractor Address

\_\_\_\_\_  
Signature

\_\_\_\_\_  
Date

\_\_\_\_\_  
Printed Name

\_\_\_\_\_  
Title



**OHIO GENERAL PERMIT AUTHORIZATION FOR STORMWATER  
DISCHARGES ASSOCIATED WITH CONSTRUCTION ACTIVITY UNDER  
THE NPDES STORMWATER POLLUTION PREVENTION PLAN**

**THE EAST OHIO GAS COMPANY, d/b/a DOMINION ENERGY OHIO  
PIR 2788 – Apple Creek  
Wooster Township, Wayne County, Ohio**

**TABLE OF CONTENTS**

<b>SECTION</b>	<b>Page</b>
<b>EXECUTIVE SUMMARY .....</b>	<b>v</b>
<b>1.0 PERMIT REQUIREMENTS.....</b>	<b>1</b>
<b>2.0 STORMWATER POLLUTION PREVENTION PLAN .....</b>	<b>2</b>
2.1    SITE/PROJECT DESCRIPTION AND LOCATION/SETTING .....	3
2.2    PRE-CONSTRUCTION AND POST-CONSTRUCTION SITE CONDITIONS ....	4
2.3    EXISTING SOIL DATA .....	4
2.4    STEEP SLOPES.....	4
2.5    PRIOR LAND USES .....	4
2.6    RECEIVING STREAMS OR SURFACE WATERS .....	4
2.7    IMPLEMENTATION SCHEDULE .....	6
2.8    SITE MAPPING .....	8
<b>3.0 CONTROLS .....</b>	<b>9</b>
3.1    PRESERVATION METHODS.....	9
3.2    EROSION CONTROL PRACTICES .....	9
3.3    RUNOFF CONTROL PRACTICES.....	12
3.4    SURFACE WATER PROTECTION.....	13
3.5    WETLAND PRACTICES.....	14
3.6    SEDIMENT CONTROL PRACTICES .....	15
3.7    POST-CONSTRUCTION STORMWATER MANAGEMENT (PCSM).....	17
3.8    OTHER CONTROLS .....	17
3.9    MAINTENANCE .....	20
3.10   INSPECTIONS .....	21

<b>4.0</b>	<b>APPROVED STATE OR LOCAL PLANS.....</b>	<b>23</b>
<b>5.0</b>	<b>EXCEPTIONS.....</b>	<b>24</b>
<b>6.0</b>	<b>NOTICE OF TERMINATION REQUIREMENTS.....</b>	<b>25</b>

## LIST OF TABLES

<b>Table</b>		<b>Page</b>
1	Permanent Stabilization .....	8
2	Temporary Stabilization .....	8
3	Summary of Onsite Streams/Rivers .....	12
4	Summary of Onsite Wetlands.....	13
5	Required Spacing and Materials for Trench Plugs.....	15

## LIST OF APPENDICES

A	Site Location Maps (highway, topographic, watershed)
B	Soils Map and Table Identifying Soil Types and Characteristics
C	Detailed Erosion and Sediment Control Location Drawings
D	Site Drawing Checklist and Logs
E	Corrective Action Log
F	Typical Upland Erosion and Sediment Control Plan Drawings
G	Typical Stream Crossing Drawings
H	Typical Wetland Crossing Drawing
I	NOI Application Documentation
J	Concrete Washout Typical Detail
K	SWP3 Inspection Forms
L	Seeding Specifications
M	Pre-Construction and Post-Constriction Runoff Volumes & Peak Rate Calculations



## **LIST OF DEFINITIONS**

BMP	Best Management Practice
C&DD	Construction and Demolition Debris
Director	Director of the Ohio Environmental Protection Agency
E&S	Erosion and Sediment
EPA	Environmental Protection Agency
General Permit	General Permit for Stormwater Discharges Associated with Construction Activities Under the National Pollutant Discharge Elimination System Permit No. OHC000006, effective April 23, 2023, expires April 22, 2028.
HUC	Hydrologic Unit Code
MS4	Municipal Separate Storm Sewer System
NOI	Notice of Intent
NOT	Notice of Termination
NPDES	National Pollutant Discharge Elimination System
OAC	Ohio Administrative Code
ORAM	Ohio Rapid Assessment Method
ORC	Ohio Revised Code
PCSM	Post-Construction Stormwater Management
PTI	Permit to Install
SPCC	Spill Prevention Control and Countermeasures
SWP3	Stormwater Pollution Prevention Plan
VAP	Voluntary Action Program

## EXECUTIVE SUMMARY

The purpose of this Stormwater Pollution Prevention Plan (SWP3) is to present procedures that will be followed during construction activities to minimize adverse impacts due to sedimentation and potential environmental pollutants resulting from storm water runoff and to reduce sediment and environmental pollutant runoff after Project completion. This SWP3 sets forth procedures to be followed during construction activities for The East Ohio Gas Company, d/b/a Dominion Energy Ohio (Dominion Energy), Pipeline Infrastructure Replacement (PIR) project, PIR 2788 – Apple Creek (Project), located in Wooster Township, Wayne County, Ohio. The procedures developed in this plan must be implemented throughout the duration of the Project.

Dominion Energy will be responsible for the development, implementation, and enforcement of this plan. Dominion Energy personnel may designate qualified representatives such as environmental inspectors or contractors to ensure the provisions of this permit are properly employed.

This document was prepared in accordance with the following documents: Ohio Department of Natural Resources, Division of Soil and Water Conservation "Rainwater and Land Development" Manual Third Edition 2006, Updated 11-6-14; Ohio Environmental Protection Agency (EPA), Authorization for Stormwater Discharges Associated with Construction Activity Under the National Pollutant Discharge Elimination System Permit OHC000006; and Ohio EPA Stormwater Program Website, <http://www.epa.state.oh.us/dsw/storm/index.aspx>.

This plan covers all new and existing discharges composed entirely of stormwater discharges associated with construction activity that enter surface waters of the State or a storm drain leading to surface waters of the State. Construction activities include any clearing, grading, excavating, grubbing and/or filling activities that disturb one (1) or more acres of land.

## 1.0 PERMIT REQUIREMENTS

The purpose of this SWP3 is to present procedures that will be followed during construction activities to minimize adverse impacts due to sedimentation resulting from storm water runoff and to reduce sediment runoff after Project completion. Operators who intend to obtain initial coverage for a stormwater discharge associated with construction activity under this General Permit Authorization for Storm Water Discharges Associated with Construction Activity Under the National Pollutant Discharge Elimination System (NPDES), Ohio EPA Permit Number OHC000006 (effective April 23, 2023 and expires April 22, 2028 (General Permit)) must submit a complete and accurate Notice of Intent (NOI) application form and appropriate fee at least 21 days prior to the commencement of construction activity. The completed NOI application is provided in **Appendix I**.

Dominion Energy must make NOIs and SWP3s available upon request of the Director of Ohio EPA; local agencies approving sediment and erosion control plans, grading plans or stormwater management plans; local governmental officials, or operators of municipal separate storm sewer systems (MS4s) receiving drainage from the permitted site.



## 2.0 STORMWATER POLLUTION PREVENTION PLAN

This SWP3 was prepared in accordance with sound engineering and/or conservation practices by a professional experienced in the design and implementation of standard erosion and sediment controls and stormwater management practices addressing all phases of construction. This SWP3 was prepared by Dominion Energy and Environmental Consulting & Technology, Inc.

This SWP3 has identified potential sources of pollution which may reasonably be expected to affect the quality of stormwater discharges associated with construction activities. This SWP3 describes and ensures the implementation of Best Management Practices (BMPs) that reduce the pollutants in stormwater discharges during construction and pollutants associated with post-construction activities to ensure compliance with Ohio Revised Code (ORC) Section 6111.04, Ohio Administrative Code (OAC) Chapter 3745-1 and the terms and conditions of the General Permit. In addition, the SWP3 must conform to the specifications of the Ohio Rainwater and Land Development Manual.

### Plan Availability

Dominion Energy must provide a copy of this SWP3 within seven (7) days upon written request by any of the following: The Director or the Director's authorized representative; a local agency approving sediment and erosion plans, grading plans or stormwater management plans; or; in the case of a stormwater discharge associated with construction activity which discharges through a municipal separate storm sewer system with an NPDES permit, to the operator of the system. A copy of the NOI and letter granting permit coverage under this General Permit must also be made available at the site.

All NOIs, General Permit approval for coverage letters, and SWP3s are considered reports that must be available to the public in accordance with the Ohio Public Records law. Dominion Energy must make documents available to the public upon request or provide a copy at public expense, at cost, in a timely manner. However, Dominion Energy may claim to Ohio EPA any portion of a SWP3 as confidential in accordance with Ohio law.

### Plan Revisions and Amendments.

The Director or authorized representative, and/or any regulatory authority associated with approval of this plan, may notify Dominion Energy at any time that the SWP3 does not meet one (1) or more of the minimum requirements. Within ten (10) days after such notification from the Director (or as otherwise provided in the notification) or authorized representative, and/or any regulatory authority associated with approval of this plan, Dominion Energy must make the required changes to the SWP3 and, if requested, must submit to Ohio EPA, and/or other regulatory authority, the revised SWP3 or a written certification that the requested changes have been made. Dominion Energy must also amend the SWP3 whenever there is a change in site design, construction, operation, or maintenance that requires the installation of BMPs or modifications to existing BMPs.

## Duty to Inform Contractors and Subcontractors.

Dominion Energy must inform all contractors and subcontractors who will be involved in the implementation of the SWP3 of the terms and conditions of the General Permit and/or other approval from a regulatory authority. Dominion Energy must maintain a written document containing the signatures of all contractors and subcontractors involved in the implementation of the SWP3 as proof acknowledging that they reviewed and understand the conditions and responsibilities of the SWP3. The written document must be created and signatures of each individual contractor must be obtained prior to their commencement of work on the construction site. Certification statements for contractors and subcontractors can be found at the beginning of this document.

### **2.1 SITE/PROJECT DESCRIPTION AND LOCATION/SETTING**

Dominion Energy is proposing to install approximately 3,900 feet of replacement natural gas pipeline (twelve [12]-inch diameter) and conduct any necessary abandonment activities under Dominion Energy's PIR Program. The purpose of this program is to replace existing pipe to ensure the safety and reliability of pipeline operations.

The PIR 2788 Project is located within Wooster Township, Wayne County, along N. Hillcrest Drive, in an existing sixty (60)-ft wide utility easement which originates at N. Hillcrest Drive and extends northeast to S. Geyers Chapel Road, and in a newly acquired sixty (60)-foot wide easement which originates as a private drive on the east side of N. Hillcrest Drive and extends east to Apple Creek. At intersections with roads with no proposed mainline replacement, small portions of pipeline may be installed to "tie in" the new pipeline to existing pipelines. Along any portions of abandoned pipeline, small areas of excavation may occur to allow the line to be purged and cut and capped. The need for any laydown and/or material storage areas will be determined by the selected construction contractor. The Project area is easily accessible from public roads as well as from a residential drive off N. Hillcrest Drive and a farm access road off S. Geyers Chapel Road.

The scope of work is to install and abandon sections of natural gas pipeline; as well as a permanent gravel access to an underground drip tank with an above ground 2" siphon and four (4) bollards. No other utilities will be constructed. The construction of new buildings is not included in the scope of work. Disturbance within the Project area will be minimized as much as possible. The area environmentally reviewed to facilitate the Project is approximately 13.0 acres. Approximately 5.4 acres will be temporarily disturbed due to excavation, filling, grading, and installation of erosion control measures. The 5.4 acres will be disturbed in phases.

The Project area is located in residential, agricultural, and undeveloped land within the Walhonding River drainage basin (Hydrologic Unit Code [HUC] 05040003). The Project area has undulating elevations. Six (6) streams and one (1) wetland are located in the Project area.

The maps included in **Appendix A** depict the location of the Project on a roadway map, U.S. Geological Survey Topographic Map, and a watershed map.

## 2.2 PRE-CONSTRUCTION AND POST-CONSTRUCTION SITE CONDITIONS

The Project does create approximately 0.20 acre of impervious area as a result of the development of the gravel access road to the 2” siphon; therefore, there will be a permanent increase in stormwater runoff. Pre-Construction and Post-Construction runoff volume and peak rate calculations are provided in **Appendix M**. All other areas disturbed by the Project will be restored to their pre-construction material, condition, and contours.

*Table 1: Runoff Coefficients Based on Land Use*

Land Use	Runoff Coefficient
Industrial and Commercial	0.8
High Density Residential (more than eight dwellings per acre)	0.5
Medium Density Residential (four to eight dwellings per acre)	0.4
Low Density Residential (less than four dwellings per acre)	0.3
Open Space and Recreational Areas	0.2

## 2.3 EXISTING SOIL DATA

The United States Department of Agriculture, Natural Resources Conservation Service (NRCS) Soil Survey was utilized to identify soil map units within the Project site. The primary soils types located within the Project include Tioga silt loam, occasionally flooded (Tg); Canfield silt loam, 2 to 6 percent slopes (CdB); and Wooster-Riddles silt loams, 6 to 12 percent slopes (WuC). A copy of the Soil Survey for the Project and a table identifying the soil types and characteristics (drainage capacity, depth to water table, K factor rating, etc.) are provided in **Appendix B**.

## 2.4 STEEP SLOPES

The Project area does exhibit steep/critical slopes. At those areas exhibiting steep/critical slopes, erosion and sediment controls appropriate for use were selected.

## 2.5 PRIOR LAND USES

Prior land uses for the Project site includes residential, agricultural, and undeveloped land.

## 2.6 RECEIVING STREAMS OR SURFACE WATERS

The Project is located within the Apple Creek subwatershed (HUC12 05040003 0602) of the Apple Creek-Killbuck Creek watershed (HUC10 05040003 06), within the Walhonding River watershed (HUC8 05040003). The first named receiving stream for the Project is Apple Creek, which is located in the Project area. Apple Creek drains into Killbuck Creek which drains south into the Walhonding River. The Walhonding River is a tributary of the Muskingum River which drains to the Ohio River. A map depicting where the Project is located within a watershed setting is included in **Appendix A**. Any rivers, streams, wetlands, and any significant ponds or ditches crossed by the Project have been included on the maps in **Appendix C**.



The following water bodies are located within the Project area: Wetland A, Stream 1 (Apple Creek), Stream 2, Stream 3, Stream 4, Stream 5, and Stream 6. Wetland A, Stream 1 (Apple Creek), Stream 4, Stream 5, and Stream 6 will be open cut and temporarily impacted. Stream 2 will also be impacted due to the installation of a temporary culvert for equipment crossing. Temporary impacts to these resources are anticipated to be authorized under Nationwide Permit #12. Stream 3 is set away from the Project work area. No impact will occur to this stream.

Wetland A is a large (over one [1] acre) riparian wetland that abuts Stream 1 (Apple Creek) within the Project area. Wetland A has forested, shrub, and emergent dominated portions. Emergent portions of Wetland A are regularly mowed and cleared to maintain farm access areas. Wetland A drains directly into Stream 1 (Apple Creek).

Stream 1 (Apple Creek) is a large perennial stream that flows east to west across the Project area. Dominant substrate types within Stream 1 (Apple Creek) include cobble and gravel. Although the assessed reach of Stream 1 (Apple Creek) is protected within a forested riparian area, the surrounding agricultural landscape likely influences sedimentation and nutrient loads within the stream. Apple Creek has been designated as Warmwater Habitat by the OEPA and the nearest sampling station #R03W47 was in partial attainment per the 2018 Integrated Water Quality Monitoring and Assessment Report.

Stream 2, an ephemeral stream, drains south through the Project area along the western side of S. Geyers Chapel Road. Stream 2 is also culverted beneath a farm access road immediately north of its confluence with Stream 1 (Apple Creek) within the eastern Project area. Substrates of Stream 2 are dominated by silt and clay/hardpan. The stream has been channelized to run parallel to the road, and water quality is likely heavily influenced by stormwater from the adjacent roadway and agricultural fields.

Stream 3, an ephemeral stream, drains northwest through the Project area. The stream has been channelized to run underneath the existing pipeline easement through a culvert and water quality is likely heavily influenced by stormwater from the surrounding residential area and agricultural fields. Substrates of Stream 3 are dominated by gravel, cobble, and sand.

Stream 4 is an intermittent stream located in the western Project area along a potential site access route. Stream 4 drains north through the Project area and Wetland A into Stream 1 (Apple Creek). Stream 4 has been heavily channelized and is culverted beneath an existing field access road. Dominant substrate types within Stream 4 include gravel and clay/hardpan. Stream 4 is likely highly influenced by stormwater from the adjacent fallow fields/maintained lawn areas.

Stream 5 is an ephemeral stream that originates in western portions of the Project area and flows north towards Stream 1 (Apple Creek) where it eventually loses bed and bank within portions of Wetland A. Dominant substrate types of Stream 5 include cobble and clay/hardpan.

Stream 6 is an ephemeral stream captured in a roadside ditch along the western edge of N. Hillcrest Drive. Dominant substrate types in Stream 6 include boulder and cobble. Stream 6 is heavily impacted by stormwater runoff from the adjacent roadway.

Floodplain associated with Stream 1 (Apple Creek) is located within the Project area. Temporary impact to this floodplain is anticipated due to construction and coordination for work within the floodplain will be conducted prior to project commencement.

The Ohio EPA conducts periodic surveys to collect water quality data on Ohio's streams and rivers. The data are incorporated into the Ohio Integrated Water Quality Monitoring and Assessment Report. The watershed monitoring data closest to the Project area indicates that Apple Creek at Ely Road is in partial attainment for Aquatic Life Use. The Watershed Assessment indicates that the watershed, as a whole, is impaired for recreational use. The water is not utilized for drinking water supply.

The project is located in Wayne County which holds a MS4 Stormwater General Permit (3GQ00139\*BG).

Dedicated asphalt and/or concrete batch plant discharges are not applicable to this Project.

## **2.7 IMPLEMENTATION SCHEDULE**

A general implementation schedule providing the sequence of major construction operations is provided below. Construction activities are expected to be initiated and completed in 2024. The specific start date will be determined by the receipt of all applicable permits and the selected construction contractors' schedule. The completion date may be affected by weather conditions. Surface stabilization at the Project site is expected to take place incrementally, as construction progresses. Once all land disturbing activities have been completed, the site must be permanently stabilized. Throughout the life of the Project, construction logs must be kept to record major dates of grading, excavating, and stabilizing.

### **1 - SITE PREPARATION FOR ENTIRE PROJECT (To be determined by the contractor)**

- Mobilization.
- Survey and stake existing pipeline and limits of construction.
- Flag/field mark wetland areas, as necessary.
- Installation/improvement to construction entrances, and installation of silt fence or other BMPs designated to control storm water at the project boundary.
- Install gravel on dirt roads, and fill-in rutted areas on existing gravel roads.

## **2 - SITE PREPARATION FOR EACH JOB (To be determined by the contractor)**

- Install BMPs (see Section 3.0) for access roads/equipment crossings at stream crossings and wetland crossings.
- Begin clearing and grubbing of the site.
- Install temporary runoff controls and erosion control devices where needed.
- Conduct grading activities, as needed.
- Monitor all erosion and sediment controls

## **3 - MAJOR CONSTRUCTION ACTIVITIES (To be determined by the contractor)**

- Excavation.
- Implement BMPs (See Section 3.0) for dewatering (if required).
- Monitor all erosion and sediment controls

## **4 - RESTORATION (To be determined by the contractor)**

- Restore grade to preconstruction contours and install permanent runoff controls, where needed.
- Installation of concrete washout (if required)
- Apply seed and mulch to all disturbed upland areas.
- Install erosion control blankets or turf matting on steep slopes.
- Monitor all erosion and sediment controls

## **5 - POST-CONSTRUCTION MONITORING (On-going until 70 percent cover reached)**

- Removal of concrete washout and disposal of washout material
- Monitor adequacy of erosion control practices.
- Remove temporary erosion and sediment controls and runoff controls once 70 percent uniform vegetative growth is achieved.
- Submit Notice of Termination.

## 2.8 SITE MAPPING

The scope of this Project is to install replacement natural gas pipeline, conduct activities associated with pipeline abandonment, and install a gravel access road to a new underground drip tank. No other utilities, buildings, roads, or parking facilities will be constructed.

Project site location maps are provided in **Appendix A**. The Soil Survey map for the Project is provided in **Appendix B**. The Project specific erosion and sediment control location drawings (in **Appendix C**) depict the limits of earth-disturbing activity, existing and proposed contours; surface water locations, relation to existing buildings and roads, the location of all erosion and sediment control measures, and the location of all construction entrances. The site drawing checklist and logs are included in **Appendix D**. Typical erosion and sediment control drawings for all sediment and erosion controls practices are also included in **Appendices F, G, and H**.



### 3.0 CONTROLS

To the extent practicable, the locations of temporary and permanent stormwater BMPs to be implemented for the Project site are shown on the drawings provided in **Appendix C**. [Some BMP locations (construction entrances, ingress/egress points, etc.) will be determined in the field upon discussion with the selected construction contractor and will be noted on the project drawings (in **Appendix A, B, and/or C**, as appropriate) at that time. The construction contractor will complete the “Site Drawing Checklist” (**Appendix D**) verifying the inclusion of these features.] The BMPs will be implemented in accordance with the Typical Drawings provided in **Appendices F, G, and H**. The erosion, sediment, and stormwater management practices to be implemented are in accordance with the standards and specification in the current edition of Ohio’s Standards for Stormwater Management, Land Development and Urban Stream Protection, Rainwater and Land Development Manual, Third Edition 2006 updated November 6, 2014.

#### 3.1 PRESERVATION METHODS

In order to preserve the existing natural condition as much as feasible, the Project will avoid clearing and grubbing where feasible, minimize the amount of soil and vegetation disturbances by phasing construction operations, and minimize disturbances to surface waters. The recommended buffer along any surface water of the state to be undisturbed is fifty (50) feet measured from the ordinary high water mark of the surface water.

Disturbance within the Project area will be minimized as much as possible. Approximately 5.4 acres will be temporarily disturbed. The 5.4 acres will be disturbed in phases.

Separation of the topsoil from the subsoil will generally be performed at residential properties, any wetlands and streams, and agricultural lands. The backfill material returned to the excavation will consist of the same material removed from the excavation, to the extent practicable.

#### 3.2 EROSION CONTROL PRACTICES

Erosion control measures provide cover over disturbed soils in order to minimize erosion. Disturbed areas must be stabilized after construction activities. Erosion control measures likely employed for the Project include: phased disturbance, clearing and grubbing, construction entrances, dust control, matting (Temporary Rolled Erosion Control Product), mulching, topsoiling, temporary seeding, permanent seeding, and sodding. Erosion Control Measures will be in accordance with the Rainwater and Land Development Manual. Typical drawings for these erosion control measures are provided in **Appendix F**.

Permanent stabilization is defined as the establishment of permanent vegetation, decorative landscape mulching, matting, sod, rip rap and landscaping techniques to provide permanent erosion control on areas where construction operations are complete or where no further disturbance is expected for at least one (1) year.

Temporary stabilization is defined as the establishment of temporary vegetation, mulching, geotextiles, sod, preservation of existing vegetation and other techniques capable of quickly

establishing cover over disturbed areas to provide erosion control between construction operations.

Final stabilization is defined and achieved when all soil disturbing activities at the site are complete and disturbed surfaces are covered with new structures, pavement, a uniform perennial vegetative cover (e.g., evenly distributed, without large bare areas) with a density of at least seventy (70) percent cover, or other equivalent stabilization measures (such as the use of landscape mulches, rip-rap, gabions or geotextiles) have been employed. In addition, all temporary erosion and sediment control practices are removed and disposed of and all trapped sediment is permanently stabilized to prevent further erosion.

Disturbed areas will be stabilized following completion of construction activities as specified in **Tables 1 and 2** below and in accordance with the site layout maps and detail sheets provided in **Appendix C**.

*Table 1: Permanent Stabilization*

<b>Area Requiring Permanent Stabilization</b>	<b>Time Frame to Apply Erosion Controls (Stabilization)</b>
Any areas that will lie dormant for one (1) year or more.	Within seven (7) days of the most recent disturbance.
Any areas within 50 feet of a surface water of the State and at final grade.	Within two (2) days of reaching final grade.
Any other areas at final grade.	Within seven (7) days of reaching final grade within that area.

*Table 2: Temporary Stabilization*

<b>Area Requiring Temporary Stabilization</b>	<b>Time Frame to Apply Erosion Controls (Stabilization)</b>
Any disturbed areas within 50 feet of a surface water of the State and not at final grade.	Within two (2) days of the most recent disturbance if the area will remain idle for more than fourteen (14) days.
For all construction activities, any disturbed areas that will be dormant for more than fourteen (14) days but less than one (1) year, and not within 50 feet of a surface water of the State.	Within seven (7) days of the most recent disturbance within the area.  For residential subdivisions, disturbed areas must be stabilized at least seven (7) days prior to transfer of permit coverage for the individual lot(s).
Disturbed areas that will be idle over winter.	Prior to the onset of winter weather.

**Clearing and Grubbing:** Clearing and grubbing is the removal of trees, brush, and other unwanted material in order to develop land for other uses or provide access for site work. Clearing generally describes the cutting and removal of above ground material, while grubbing is the removal of roots, stumps, and other unwanted material below existing grade. Clearing and grubbing includes the proper disposal of materials and the implementation of BMPs in order to minimize exposure of soil to erosion and causing downstream sedimentation.

Construction Entrance: A construction entrance is a method of erosion control that is used to reduce the amount of mud tracked off-site with construction traffic. A construction entrance is a stabilized pad of stone underlain with a geotextile. These entrances are located at points of ingress/egress of construction traffic.

Dust Control: Dust control is a method of erosion control that involves preventing or reducing dust from exposed soils or other sources during land disturbing, demolition, and construction activities to reduce the presence of airborne substances which may present health hazards, traffic safety problems, or harm animal or plant life.

Matting/Temporary Rolled Erosion Control Product (TREC): TRECPs are a method of erosion control which is a degradable manufactured material used to stabilize easily eroded areas while vegetation becomes established. Temporary Rolled Erosion Control Products are degradable products composed of biologically, photo chemically, or otherwise degradable materials. TRECPs consist of erosion control netting, open weave textiles, and erosion control blankets and mattings. These products reduce soil erosion and assist vegetative growth by providing temporary cover from the erosive action of rainfall and runoff while providing soil-seed contact.

Mulching: Mulching is a temporary or permanent method of erosion control used to protect exposed soil or freshly seeded areas from the direct impact of precipitation by providing a temporary surface cover. Mulch also helps establish vegetation by conserving moisture and creating favorable conditions for seeds to germinate. Mulch must be used liberally throughout construction to limit the areas that are bare and susceptible to erosion. Mulch can be used in conjunction with seeding to establish vegetation or by itself to provide erosion control when the season does not allow grass to grow. Mulch and other vegetative practices must be applied on all disturbed portions of construction-sites that will not be re-disturbed for more than fourteen (14) days.

Permanent Seeding: Permanent seeding is a method of erosion control used to permanently stabilize soil on construction sites where land-disturbing activities, exposed soil, and work has been completed or is not scheduled for more than twelve (12) months. Permanent seeding must be applied to any disturbed areas or portions of construction sites at final grade. Permanent seeding must not be delayed on any one portion of the site at final grade while construction on another portion of the site is being completed. Permanent seeding must be completed in phases, if necessary. Permanent vegetation is used to stabilize soil, reduce erosion, prevent sediment pollution, reduce runoff by promoting infiltration, and provide stormwater quality benefits offered by dense grass cover.

Phased Disturbance: Phased disturbance is a method of erosion control that limits the total amount of grading at any one time and sequences operations so that at least half the site is either left as undisturbed vegetation or re-stabilized prior to additional grading operations. This approach actively monitors and manages exposed areas so that erosion is minimized and sediment controls can be more effective in protecting aquatic resources and downstream landowners.

Sodding: Sodding is a method of erosion control that utilizes rolls or mats of turf grass to provide immediate stabilization to bare soils. It is especially useful in highly erosive areas such as drainage

ways and on slopes that will be mowed. Sod may be used where immediate cover is required or preferred and where vegetation will be adequate stabilization such as minor swales, around drop inlets, and lawns.

Temporary Seeding: Temporary seeding is a method of erosion control used to temporarily and quickly stabilize soil on construction sites where land-disturbing activities have been initiated but not completed. Appropriate rapidly growing annual grasses or small grains must be planted on the disturbed areas. Temporary seeding effectively minimizes the area of a construction site prone to erosion and must be used everywhere the sequence of construction operations allows vegetation to be established. Temporary seeding must be applied on exposed soil where additional work (grading, etc.) is not scheduled for more than fourteen (14) days. Mixes to be applied are specific to the time of year the seeding will take place and the location of the Project within the state.

Topsoiling: During grading operations, topsoil and the upper most organic layer of soil will be stripped and stockpiled and then subsequently replaced on the newly graded areas. Topsoil provides a more suitable growing medium than subsoil or on areas with poor moisture, low nutrient levels, undesirable pH, or in the presence of other materials that would inhibit establishment of vegetation. Replacing topsoil helps plant growth by improving the water holding capacity, nutrient content, and consistency of the soils.

### **3.3 RUNOFF CONTROL PRACTICES**

Temporary and permanent runoff control is important on development sites to minimize on-site erosion and to prevent off-site sediment discharge. Runoff control methods likely implemented for this Project include dewatering measures, compost sock check dams, and waterbars. Runoff control measures will be in accordance with Chapter 4 and 5 of the Rainwater and Land Development Manual.

Dewatering Measures. Dewatering consists of providing an area for receiving and treating surface runoff and groundwater pumped from excavation or work areas prior to being released off the site, such as desilting basins or sediment traps. For project areas without these detention features, dewatering typically consists of the use of filter devices (e.g. filter bags) to treat and release water removed from excavation. Filter bags should discharge to an upland location if possible. These practices reduce sediment impacts to downstream water resources.

Compost Sock Check Dam. Compost sock check dams are dams constructed in swales, grassed waterways or diversions comprised of a compost filter sock (staked in place). Compost sock check dams reduce the velocity of concentrated flows thereby reducing erosion within the swale or waterway.

Waterbar. A waterbar is a diversion constructed across the slope of an access road or utility right-of-way. Waterbars are used to reduce concentrated runoff on unpaved road surfaces, thus reducing water accumulation and erosion gullies from occurring. Waterbars divert runoff to road side swales, vegetated areas, or settling ponds.



### 3.4 SURFACE WATER PROTECTION

The Project area encompasses six (6) streams and one (1) wetland (see Section 2.6). Waters must be protected by avoiding crossing of streams and wetlands where feasible and using sediment and erosion control practices to prevent sediment-laden runoff from reaching the surface waters.

Surface Waters of the State Protection. If construction activities disturb areas adjacent to surface waters of the State, structural practices must be designed and implemented onsite to protect all adjacent surface waters of the State from the impacts of sediment runoff. No structural sediment controls (e.g., the installation of silt fence or a sediment settling pond) must be used in a surface water of the State. For all construction activities immediately adjacent to surface waters of the State, it is recommended that a setback of at least 25 feet, as measured from the ordinary high water mark of the surface water, be maintained in its natural state as a permanent buffer.

Where impacts within this setback area are unavoidable due to the nature of the construction activity (e.g., stream crossings for roads or utilities), the Project must be designed such that the number of crossings and the width of the disturbance within the setback area are minimized.

In order to minimize the amount of disturbance and sedimentation caused by work at wetland crossings, every effort will be made to minimize impacts. Movement across waters will be limited to necessary equipment only. BMPs for vehicle crossing of streams and wetlands will be utilized when practical. Dominion will employ a typical temporary equipment crossing at each crossing location. These crossing methods are found on the typical drawings in **Appendices G and H**. All wetland crossings will be restored to pre-construction grades, contours, and, when feasible, vegetation type. Dominion will obtain all necessary wetland crossing permits from federal and state regulatory agencies. Summaries of the onsite surface waters and any impacts are provided in **Tables 3 and 4**.

Surface Water Utility Crossing. Surface water utility crossings include pipeline, power line, or road construction projects that cross streams, rivers, or wetlands. Measures used to minimize damage from the construction of utilities across streams and wetlands start in the planning stages of a project and continue through site restoration.

Temporary Surface Water Crossing. A temporary surface water crossing provides construction traffic temporary access across a surface water while reducing the amount of disturbance and sediment pollution. It is a temporary practice which includes restoring the crossing area after construction. The typical kinds of surface water crossings are: bridges, timber mats, culverts and fords. Each has specific applications and each is designed to minimize surface water damage by leaving wetland areas and stream banks stable and vegetated.

Table 3: Summary of Onsite Streams/Rivers

Stream ID	Stream Length (lf) within Project Area	Bankfull Width (feet)	Flow Regime	Substrate Type(s)	Designation/ Classification <sup>1</sup>	Crossing Method <sup>2</sup>	Impacts - Upstream to Downstream Length (lf)	Impacts- Trench Crossing Length (lf)
1 (Apple Creek)	180	48	Perennial	Cobble, gravel	Warm Water Habitat	Open Cut	52	48
2	155	2	Ephemeral	Silt, clay/hardpan	Modified Class I PHW1	Culvert	68	0 <sup>3</sup>
3	83	6	Ephemeral	Gravel/sand	Modified Class II PHW	Avoid	0	0
4	93	9	Intermittent	Gravel, clay/hardpan	Modified Class II PHW	Open Cut	44	9
5	83	4	Ephemeral	cobble, clay/hardpan	Class II PHW	Open Cut	9	4
6	673	4	Ephemeral	boulder, cobble	Modified Class II PHW	Open Cut	10	4

Notes:

- 1 Designation determination made using Quality Habitat Evaluation Index (QHEI) and Headwater Habitat Evaluation Index (HHEI) scoring methods.
- 2 Project Managers must approve changes to crossing methods.
- 3 Impacts to Stream 2 will involve the installation of a temporary culvert for equipment access and will not involve trenching.

Table 4: Summary of Onsite Wetlands

Wetland ID	Vegetation Cover Type within the Project Area	Area within ROW (acres)	ORAM <sup>1</sup> Category	Crossing Method <sup>2</sup>	Impact Area (acres)	Impacts Length of Wetland Crossing (lf)
A	PEM/PSS/PFO	2.380	2	Open Cut	0.924	671

Notes:

- 1 Ohio Rapid Assessment Method
- 2 Project Managers must approve changes to crossing methods.

### 3.5 WETLAND PRACTICES

Concentrated stormwater runoff from proposed BMPs to natural wetlands must be converted to diffuse flow before the runoff enters the wetlands. The flow must be released such that no erosion occurs downslope. Level spreaders may need to be placed in series, particularly on steep sloped sites, to ensure non-erosive velocities. Other structural BMPs may be used between stormwater features and natural wetlands, in order to protect the natural hydrology, hydroperiod, and wetland flora. If Dominion Energy proposes to discharge to natural wetlands, a hydrologic analysis must be performed. Dominion Energy must attempt to match the pre-development hydroperiods and hydrodynamics that support the wetland. Dominion Energy must assess whether their construction activity will adversely impact the hydrologic flora and fauna of the wetland. Practices such as vegetative buffers, infiltration basins, conservation of forest cover, and the preservation of intermittent streams, depressions, and drainage corridors may be used to maintain wetland hydrology.

### 3.6 SEDIMENT CONTROL PRACTICES

All Project activities will occur within the areas indicated on site drawings in **Appendix C**. All Sediment Control Devices will match those indicated on the mapping in **Appendix C**. Minor adjustments to control devices (type, location, etc.) deemed necessary to maintain compliance can be made on the project mapping. The location of any laydown and/or material storage areas will be determined in the field upon discussion with the selected construction contractor and will be noted on the project site drawings at that time. The “Site Drawing Checklist” (**Appendix D**) will be completed, verifying the inclusion of these features or minor adjustments. Any necessary mainline to mainline tie-ins (at intersections with streets with no proposed mainline replacement) will also be noted on the drawings. Construction activities for this Project will be limited to the Limit of Disturbance of 5.4 acres. Sediment Control Practices must treat runoff allowing sediments to settle and/or divert flows away from exposed soils or otherwise limit runoff from exposed areas. Structural practices must be used to control erosion and trap sediment from a disturbed site. Methods of control that may be used include, among others: silt fence, storm drain inlet protection, filter socks, and trench plugs. All sediment control practices must be capable of ponding runoff in order to be considered functional. Earth diversion dikes or channels alone are not considered a sediment control practice unless those are used in conjunction with a sediment settling pond. Sediment Controls must be designed, installed, and maintained in accordance with the requirements set forth in Chapter 6 of the Ohio Rainwater and Land Development Manual, and/or Ohio General Permit OHC000006. Dominion Energy discourages the use of haybales unless utilized as a secondary treatment element in conjunction with another erosion and sediment control(s) and only if approved by Dominion Energy.

Timing. Sediment control structures must be present, as indicated or otherwise deemed to be necessary, and must be functional throughout the course of earth disturbing activity. Sediment basins and perimeter sediment barriers must be implemented prior to grading and within seven (7) days from the start of grubbing. Sediment control structures must continue to function until the up-slope development area is restabilized. As construction progresses and the topography is altered, appropriate controls must be constructed or existing controls altered to address the changing drainage patterns.

Silt Fence. Silt fence is a temporary method of sediment control that is used in sheet-flow areas to encourage the ponding of runoff and settling of sediments. It consists of a geotextile fabric secured to wood or steel posts that have been trenched into the ground. It is installed downslope of the disturbed area, installed along slopes, at bases of slopes on a level contour, and around the perimeter of a site as a final barrier to sediment being carried off site. Maximum drainage area and slopes must be considered when determining the appropriateness of silt fence. Silt fence is removed after permanent vegetation is established.

Silt fence must be installed where indicated on the site drawings and as needed throughout the Project site where construction activity is likely to cause sediment-laden runoff to be carried offsite and into downstream surface waters. After construction is completed and the Project site has been permanently stabilized, silt fence must be removed and disposed of at an appropriate offsite disposal facility.

Placing silt fence in a parallel series does not extend the size of the drainage area. Stormwater diversion practices must be used to keep runoff away from disturbed areas and steep slopes where practicable. Such devices, which include swales, dikes or berms, may receive stormwater runoff from areas up to ten (10) acres.

See the silt fence detail located in **Appendix F** (for additional information on proper installation procedures).

Inlet Protection. Storm drain inlet protection devices remove sediment from stormwater before it enters storm sewers and downstream areas. Inlet protection devices may consist of washed gravel or crushed stone, geotextile fabrics, and other materials that are supported around or across storm drain inlets. Inlet protection is installed to capture some sediment and reduce the maintenance of storm sewers and other underground piping systems prior to the site being stabilized. Due to their poor effectiveness, inlet protection is considered a secondary sediment control to be used in conjunction with other more effective controls. Other erosion and sediment control practices must minimize sediment laden water entering active storm drain systems, unless the storm drain system drains to a sediment settling pond. Generally, inlet protection is limited to areas draining less than one (1) acre; areas of one or more acres will require a sediment settling pond.

Filter Sock. Filter socks are sediment-trapping devices using compost inserted into a flexible, permeable tube. Filter socks trap sediment by filtering water passing through the berm and allowing water to pond, creating a settling of solids. Filter socks may be a preferred alternative where equipment may drive near or over sediment barriers, as they are not as prone to complete failure as silt fence if this occurs during construction. Driving over filter socks is not recommended; however, if it should occur, the filter sock must be inspected immediately, repaired, and moved back into place as soon as possible. Typically, filter socks can handle the same water flow or slightly more than silt fence. For most applications, standard silt fence is replaced with twelve (12)-inch diameter filter socks.

Trench Plugs. Trench Plugs are required at each side of streams and wetlands crossings completed by trenching, regardless of trench slope. These requirements supplement DEO’s general construction practice for the placement of plugs in trenches on steep slopes. Trench plugs will also be installed if it is determined that flooding at the low point elevation of a pipeline will adversely affect the adjacent property. Installation will be in accordance with the details depicted in **Detail F-9** and **Table 5** below.

*Table 5: Required Spacing and Materials for Trench Plugs*

<b>Trench Slope (%)</b>	<b>Spacing (ft)</b>	<b>Plug Material</b>
< 5	*	*
5 – 15	500	Sand or Earth** Filled Sacks
15 – 25	300	Sand or Earth** Filled Sacks
25 – 35	200	Sand or Earth** Filled Sacks
35 – 100	100	Sand or Earth** Filled Sacks
> 100	50	Cement Filled Bags (Wetted) or Mortared Stone



- \* Trench Plugs are required at each side of all stream, river or water-body crossings completed by trenching, regardless of trench slope; otherwise not required.
- \*\* Topsoil may not be used to fill sacks.

Modifying Controls. If periodic inspections or other information indicates a control has been used inappropriately or incorrectly, Dominion Energy must replace or modify the control for site conditions.

### **3.7 POST-CONSTRUCTION STORMWATER MANAGEMENT (PCSM)**

The proposed disturbance associated with the Project is temporary; therefore, no permanent stormwater structures will be required. The Project area will be restored to original contours and re-vegetated. No impervious areas will be created for this Project.

### **3.8 OTHER CONTROLS**

In some instances, a non-sediment pollutant source may become present on the Project site and pollution controls may be required.

#### **Non-Sediment Pollutant Controls**

Handling of Toxic or Hazardous Materials. All construction personnel, including subcontractors who may use or handle hazardous or toxic materials, must be made aware of the general guidelines regarding management and disposal of toxic or hazardous construction wastes. This can be accomplished by training for construction personnel by the Contractor or by Dominion Energy.

Waste Disposal. Containers (e.g., dumpsters, drums) must be available for the proper collection of all waste material including construction debris, sanitary garbage, petroleum products, and any hazardous materials to be used on-site. Containers must be covered, as required, and not leaking. All waste material must be disposed of at facilities approved by the Ohio EPA for that material. Ensure storage time frames are not exceeded.

Clean Hard Fill. No Construction related waste materials are to be buried on-site. By exception, clean fill (clean bricks, hardened concrete, and soil) may be utilized in a way which does not encroach upon natural wetlands, streams, or floodplains or result in the contamination of waters.

Construction and Demolition Debris (C&DD). C&DD waste will be disposed of in an Ohio EPA permitted C&DD landfill as required by ORC 3714 and approved by Dominion Energy.

Construction Chemical Compounds. Storing, mixing, pumping, transferring or other handling of construction chemicals such as fertilizer, lime, asphalt, concrete drying compounds, and all other potentially hazardous materials must be done in an area away from any waterbody, ditch, or storm drain.

Equipment Fueling and Maintenance. Oil changing, equipment refueling, maintenance on hydraulic systems, etc., must be performed away from waterbodies, ditches, or storm drains, and

in an area designated for that purpose. The designated area must be equipped for recycling oil and catching spills. Secondary containment must be provided for all fuel and oil storage tanks. These areas must be inspected every seven (7) days and within 24 hours of a one-half (0.5)-inch or greater rain event to ensure there are no exposed materials which would contaminate stormwater. Site operators must be aware that Spill Prevention Control and Countermeasures (SPCC) requirements may apply. An SPCC plan is required for sites with accumulative aboveground storage of 1,320 gallons or more, or 42,000 gallons of underground storage.

No detergent may be used to wash vehicles. Wash waters will be treated in a sediment basin or alternative control which provides equivalent treatment prior to discharge.

Concrete Wash Water and Wash Outs. Concrete wash water must not be allowed to flow to streams, ditches, storm drains, or any other water conveyance. A lined sump or pit with no potential for discharge must be constructed if needed to contain concrete wash water. Field tile (agricultural drain tiles) or other subsurface drainage structures within ten (10) feet of the concrete sump or wash pit must be cut and plugged. Concrete wash water is wastewater and thus is not permitted to be discharged under the provisions of Ohio EPA's Construction General Permit which only allows the discharge of stormwater. Concrete washout details are located in **Appendix J**. The location for concrete washout will be determined in the field as necessary.

Spill Reporting Requirements. In the event of a spill of a regulated or hazardous material, immediately contact the Dominion Energy ECC assigned to the site or Project. The Dominion Energy ECC (if Dominion Energy ECC not available, other Dominion Energy Environmental staff) will coordinate spill reporting to the appropriate agencies. Spills on pavement must be absorbed with sawdust, kitty litter or other absorbent material. Spills to land require excavation of the contaminated material. Wastes generated from spill cleanup must be disposed of in accordance with applicable Federal, State, and Local waste regulations. Hazardous or industrial wastes including, but not limited to, most solvents, gasoline, oil-based paints, oil, grease, battery acid, muriatic acid, and cement curing compounds require special handling<sup>1</sup>. Spills must be reported to Ohio EPA (1-800-282-9378). Spills of 25 gallons or more of petroleum products must be reported to Ohio EPA (1-800-282-9378), the local fire department, and the Local Emergency Planning Committee within thirty (30) minutes of the discovery of the release. All spills (no matter how small), which result in contact with waters of the state, must be reported to Ohio EPA's Hotline. Spills of hazardous substances, extremely hazardous substances, petroleum, and objectionable substances that are of a quantity, type, duration, and in a location as to damage the waters of the state must be immediately reported to the Ohio EPA's Regional Environmental Coordinator.

---

<sup>1</sup> The Federal Resource Conservation and Recovery Act (RCRA) requires that all wastes generated by industrial activity, including construction activities, be evaluated to determine if the waste is hazardous, non-hazardous or special wastes. Hazardous waste and special wastes have specific handling and disposal requirements which must be met to comply with RCRA. Additional information regarding the waste evaluation process and the proper handling and disposal requirements for wastes can be found in the following Dominion Guidance Documents: "Hazardous Waste Guidance", "Hazardous Waste Guidance Labeling", "Hazardous Waste Guidance Labeling - Appendix A", "Nonhazardous Waste Management", "Universal Waste Management", "Universal Waste Guidance - Appendix A - Labeling Matrix", and "Used Oil and Oil Filter Management". Consult with the DES ECC assigned to the site or project for advice.

Contaminated Soils. If substances such as oil, diesel fuel, hydraulic fluid, antifreeze, etc. are spilled, leaked, or released onto the soil, the soil must be dug up and disposed of at a licensed sanitary landfill or other approved petroleum contaminated soil remediation facility (not a construction/demolition debris landfill) which has been approved by Dominion Energy.

Open Burning. Waste disposal by open burning is prohibited by Dominion Energy.

Dust Controls/Suppressants. Dust control is required to prevent nuisance conditions. Dust controls must be used in accordance with the manufacturer's specifications and not be applied in a manner, which would result in a discharge to waters of the state. Isolation distances from bridges, catch basins, and other drainage ways must be observed. Application (excluding water) may not occur when precipitation is imminent as noted in the short term forecast. Used oil may not be applied for dust control. Watering must be done at a rate that prevents dust but does not cause soil erosion. Chemical stabilizers and adhesives must not be used, unless written permission is received from Ohio EPA.

Air Permitting Requirements. All contractors and subcontractors must be made aware that certain activities associated with construction will require air permits. Activities including, but not limited to, mobile concrete batch plants, mobile asphalt plants, concrete crushers, generators, etc., will require specific Ohio EPA Air Permits for installation and operation. Dominion Energy must seek authorization from the corresponding district of Ohio EPA for these activities. Notification for Restoration and Demolition must be submitted to Ohio EPA for all commercial sites to determine if asbestos abatement actions are required.

Process Wastewater/Leachate Management. All contractors must be made aware that Ohio EPA's Construction General Permit only allows the discharge of stormwater. Other waste discharges including, but not limited to, vehicle and/or equipment washing, leachate associated with on-site waste disposal, concrete wash outs, etc. are a process wastewater. These types of wastewaters are not authorized for discharge under the General Stormwater Permit associated with Construction Activities. All process wastewaters must be collected and properly disposed at an Dominion Energy approved disposal facility. In the event there are leachate outbreaks (water that has passed through contaminated material and has acquired elevated concentrations of the contaminated material) associated with onsite disposal, measures must be taken to isolate this discharge for collection and proper disposal at an Dominion Energy approved disposal facility. Investigative measures and corrective actions must be implemented to identify and eliminate the source of all leachate outbreaks.

Permit to Install (PTI) Requirements. All contractors and subcontractors must be made aware that a PTI must be submitted and approved by Ohio EPA prior to the construction of all centralized sanitary systems, including sewer extensions, and sewerage systems (except those serving one (1), two (2), and three (3) family dwellings) and potable water lines. The issuance of an Ohio EPA Construction General Stormwater Permit does not authorize the installation of any sewerage system where Ohio EPA has not approved a PTI. If necessary, Dominion Energy will acquire the PTI or Dominion Energy will require the contractor to acquire the PTI.

Compliance with Other Requirements. This plan is consistent with State and/or local waste disposal, sanitary sewer or septic system regulations including provisions prohibiting waste disposal by open burning. Contaminated soils are not expected to be encountered on this Project. If they are encountered within the limits of construction, they will be managed and disposed of properly by trained personnel.

Trench and Groundwater Control. There must be no turbid discharges to surface waters of the State resulting from dewatering activities. If trench or groundwater contains sediment, it must pass through a sediment settling pond or other equally effective sediment control device, prior to being discharged from the construction site. Alternatively, sediment may be removed by settling in place or by dewatering into a sump pit, filter bag, or comparable practice. Groundwater dewatering which does not contain sediment or other pollutants is not required to be treated prior to discharge. However, care must be taken when discharging groundwater to ensure that it does not become pollutant laden by traversing over disturbed soils or other pollutant sources. Discharge of contaminated groundwater is not authorized.

Contaminated Sediment. Where construction activities are to occur on sites with historical contamination, operators must be aware that concentrations of materials that meet other criteria (is not considered a Hazardous Waste, meeting VAP standards, etc.) may still result in stormwater discharges in excess of Ohio Water Quality Standards. Such discharges are not authorized and may require coverage under a separate individual or general remediation permit. Contaminated soil stockpiles shall be protected from discharges by covering the contaminated soil with a tarp or other such material which will prohibit water from coming in contact with the soils. Contaminated soils can also be removed from the site and disposed of at a Dominion Energy approved facility.

### **3.9 MAINTENANCE**

All temporary and permanent control measures must be maintained and repaired as needed to ensure continued performance of their intended function. All sediment control measures must be maintained in a functional condition until all up slope areas are permanently stabilized. The following maintenance procedures will be conducted to ensure the continued performance of control practices.

- Qualified personnel must inspect all BMPs at least once every seven (7) days and after any storm event greater than one-half inch of rain per 24-hour period by the end of the next calendar day, excluding weekends and holidays, unless work is scheduled. Rainfall amounts will be determined by Dominion Energy personnel or a designated representative using National Weather Service or other acceptable resources such as an on-site rain gauge, and determine if the SWP3 has been properly implemented.
- Maintenance or repair of BMPs must be completed by the designated contractor within three (3) days of the date of the inspection that revealed a deficiency. For sediment ponds, repair or maintenance is required within ten (10) days of the date of the inspection.
- Off-site vehicle tracking of sediments and dust generation must be minimized. Temporary construction entrances must be provided where applicable to help reduce vehicle tracking



of sediment. Any paved roads adjacent to the site entrance must be swept daily to remove excess mud, dirt, or rock tracked from the site, as necessary.

### 3.10 INSPECTIONS

The following inspection practices must be followed once site activities have commenced and erosion and sediment control measures have been installed.

- All onsite controls must be inspected by Dominion Energy personnel or a designated representative at least once every seven (7) calendar days and after any storm event greater than one-half inch of rain per 24-hour period by the end of the next calendar day, excluding weekends and holidays, unless work is scheduled.
- Inspection frequency may be reduced to at least once every month if the entire site is temporarily stabilized or runoff is unlikely due to weather conditions (e.g., site is covered with snow, ice, or the ground is frozen). A waiver of inspection requirements is available from Ohio EPA until one (1) month before thawing conditions are expected to result in a discharge if all of the following conditions are met: the Project is located in an area where frozen conditions are anticipated to continue for extended periods of time (i.e., more than one (1) month); land disturbance activities have been suspended; and the beginning and ending dates of the waiver period are documented in the SWP3. Dominion Energy will obtain the waiver at the request of the contractor.
- Once a definable area has reached final stabilization as defined in Section 3.2 Erosion Control Practices, the area must be marked on the SWP3 and no further inspection requirements apply to that portion of the site.
- A Dominion Energy or a designated representative “qualified inspection personnel” must conduct inspections to ensure that the control practices are functional and to evaluate whether the SWP3 is adequate and properly implemented in accordance with the schedule or whether additional control measures are required.
- Following inspection, a checklist must be completed and signed by the qualified inspection personnel representative. The inspection form and checklist is provided in **Appendix K**. The record and certification must be signed in accordance with Ohio Permit OHC000006.
- Inspection reports must be maintained for three (3) years following the submittal of a Notice of Termination.
- For BMPS that require repair or maintenance, BMPs must be repaired or maintained within three (3) days of the inspection; sediment settling ponds must be repaired or maintained within ten (10) days of the inspection.
- For BMPs that are not effective and that another, more appropriate BMP is required, the SWP3 must be amended and the more appropriate BMP must be installed within ten (10) days of the inspection.

- For BMPs depicted on the SWP3 that have not been actually installed onsite, the control practice must be implemented within ten (10) days from the inspection.

#### **4.0 APPROVED STATE OR LOCAL PLANS**

This SWP3 must comply, unless exempt, with the lawful requirements of municipalities, counties, and other local agencies regarding discharges of stormwater from construction activities. All erosion and sediment control plans and stormwater management plans approved by local officials must be retained.

## **5.0 EXCEPTIONS**

If specific site conditions prohibit the implementation of any of the erosion and sediment control practices contained in this plan or site specific conditions are such that implementation of any erosion and sediment control practices contained in this plan will result in no environmental benefit, then Dominion Energy must provide justification for rejecting each practice based on site conditions. Dominion Energy may request approval from Ohio EPA and any other applicable regulatory authority to use alternative methods if Dominion Energy can demonstrate that the alternative methods are sufficient to protect the overall integrity of receiving streams and the watershed.



## **6.0 NOTICE OF TERMINATION REQUIREMENTS**

Once a site reaches final stabilization and construction activities have ceased, NPDES permit coverage is terminated by filing a notice of termination (NOT). The NOT must be filed within 45 days of reaching final stabilization. The terms and conditions of this permit must remain in effect until a signed NOT form is submitted. NOT forms must be submitted in accordance with Ohio Permit OHC000006.

Similarly, a notice of completion must be provided to any municipalities, counties, and other local agencies that require such notice.

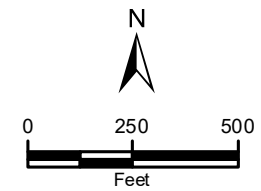
---

## **APPENDIX A**

### **Site Location Maps**



 Project Study Area



Base Layer: ESRI Street Map 2019

**Appendix A - Figure 1  
Site Location**


PIR 2788 - Apple Creek  
Dominion Energy Ohio  
Wayne County, Ohio

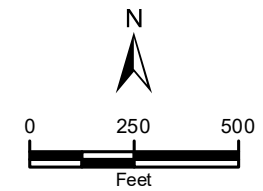
Date: 1/17/2024







 Project Study Area



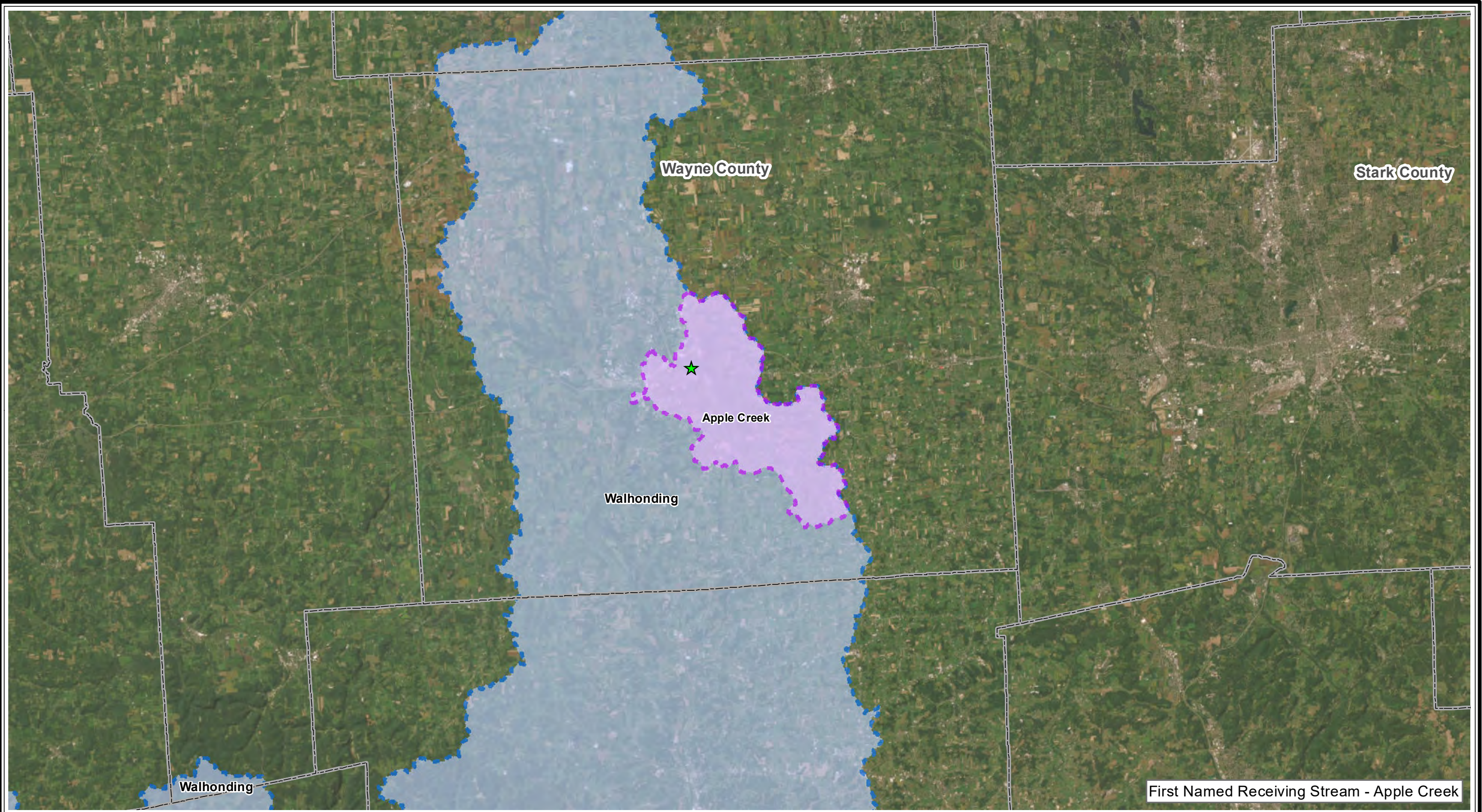
Base Layer: US TopoMaps, 1998

**Appendix A - Figure 2**  
**USGS Topographic - Wooster Quadrangle**

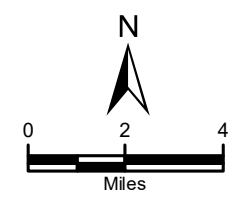
PIR 2788 - Apple Creek  
Dominion Energy Ohio  
Wayne County, Ohio  
Date: 1/17/2024







- ★ Project Study Area - Approx. Location
- HUC 12: Apple Creek
- HUC 8: Walhonding
- County Boundaries



Sources: USGS NAIP Aerial

First Named Receiving Stream - Apple Creek

**Appendix A - Figure 3  
Watershed Location Map**

PIR 2788 - Apple Creek  
Dominion Energy Ohio  
Wayne County, Ohio  
Date: 1/17/2024





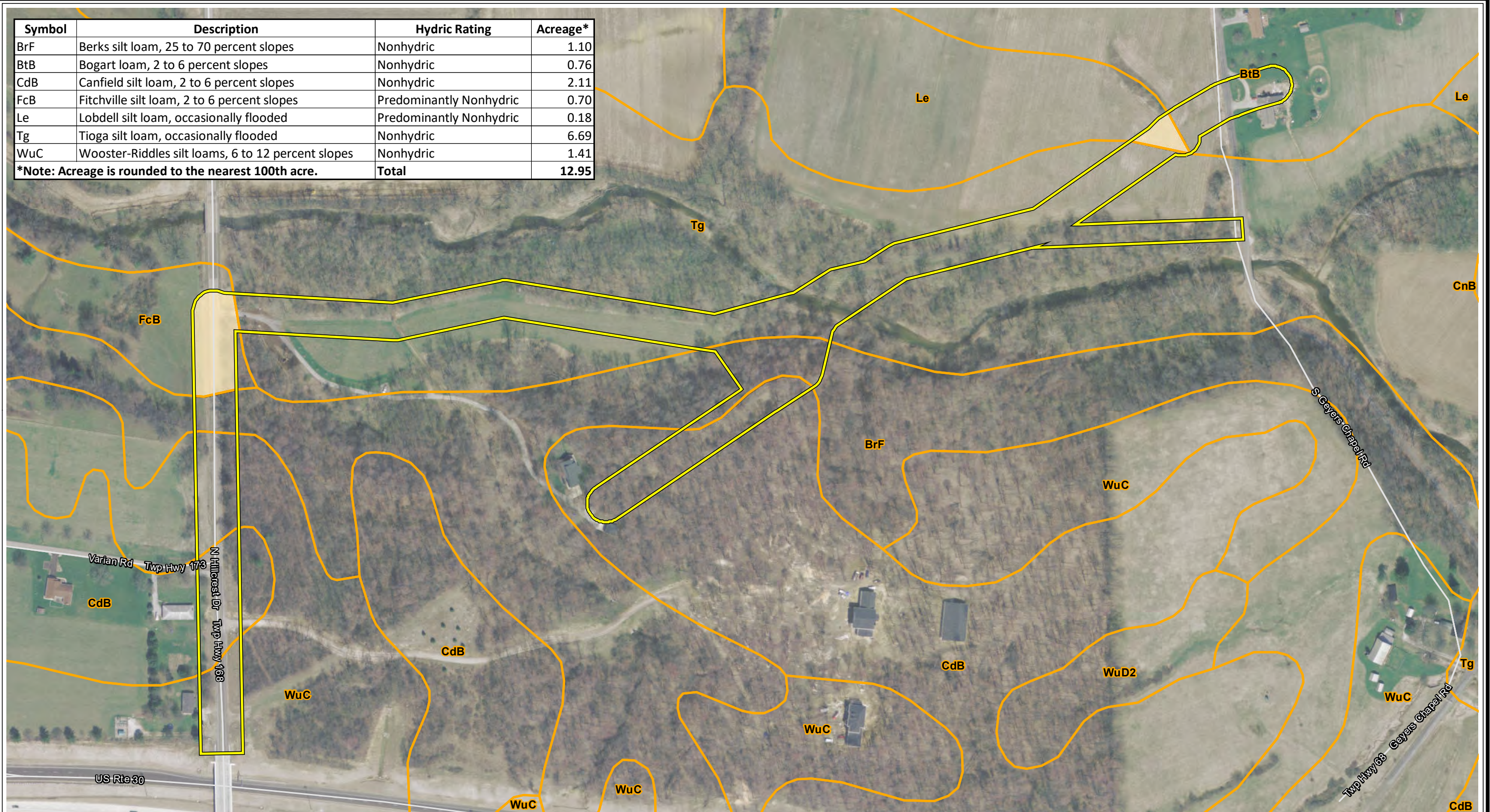
---

## **APPENDIX B**

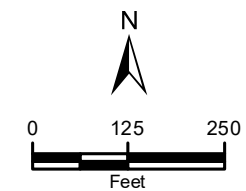
### **Soil Map and Table**



Symbol	Description	Hydric Rating	Acreage*
BrF	Berks silt loam, 25 to 70 percent slopes	Nonhydic	1.10
BtB	Bogart loam, 2 to 6 percent slopes	Nonhydic	0.76
CdB	Canfield silt loam, 2 to 6 percent slopes	Nonhydic	2.11
FcB	Fitchville silt loam, 2 to 6 percent slopes	Predominantly Nonhydic	0.70
Le	Lobdell silt loam, occasionally flooded	Predominantly Nonhydic	0.18
Tg	Tioga silt loam, occasionally flooded	Nonhydic	6.69
WuC	Wooster-Riddles silt loams, 6 to 12 percent slopes	Nonhydic	1.41
<b>*Note: Acreage is rounded to the nearest 100th acre.</b>		<b>Total</b>	<b>12.95</b>



- Project Study Area
- NRCS Soils
- NRCS Soils - Hydric Rating
- Predominantly Nonhydic
- Nonhydic



Base Layer: OSIP Aerial, 2016

**Appendix B - Figure 1  
NRCS Soil Survey Units**

PIR 2788 - Apple Creek  
Dominion Energy Ohio  
Wayne County, Ohio

Date: 1/17/2024





**Appendix B - Soil Types and Descriptions**

<b>Soil Type</b>	<b>Map Symbol</b>	<b>Slope</b>	<b>Material</b>	<b>Drainage Class</b>	<b>Location</b>	<b>Depth to Water Table (cm)</b>	<b>Depth to Restrictive Feature (cm)</b>	<b>K Factor, Whole Soil (Erodibility)</b>
Tioga silt loam, occasionally flooded	Tg	1%	Alluvium	Well drained	Floodplains	137	>200	0.32
Canfield silt loam, 2 to 6 percent slopes	CdB	4%	Till	Moderately well drained	Till plains	38	66	0.37
Wooster-Riddles silt loams, 6 to 12 percent slopes	WuC	9%	Till	Well drained	Ridges, hills, terraces	153	69	0.43
Berks silt loam, 25 to 70 percent slopes	BrF	48%	Residuum weathered from sandstone and shale and/or residuum weathered from siltstone	Well drained	Valleys, floodplains	>200	71	0.37
Bogart loam, 2 to 6 percent slopes	BtB	4%	Stratified outwash	Moderately well drained	Terraces, lake plains	84	>200	0.28
Fitchville silt loam, 2 to 6 percent slopes	FcB	4%	Glaciolacustrine deposits	Somewhat poorly drained	Terraces	23	>200	0.37
Lobdell silt loam, occasionally flooded	Le	1%	Alluvium	Moderately well drained	Floodplains	84	>200	0.37

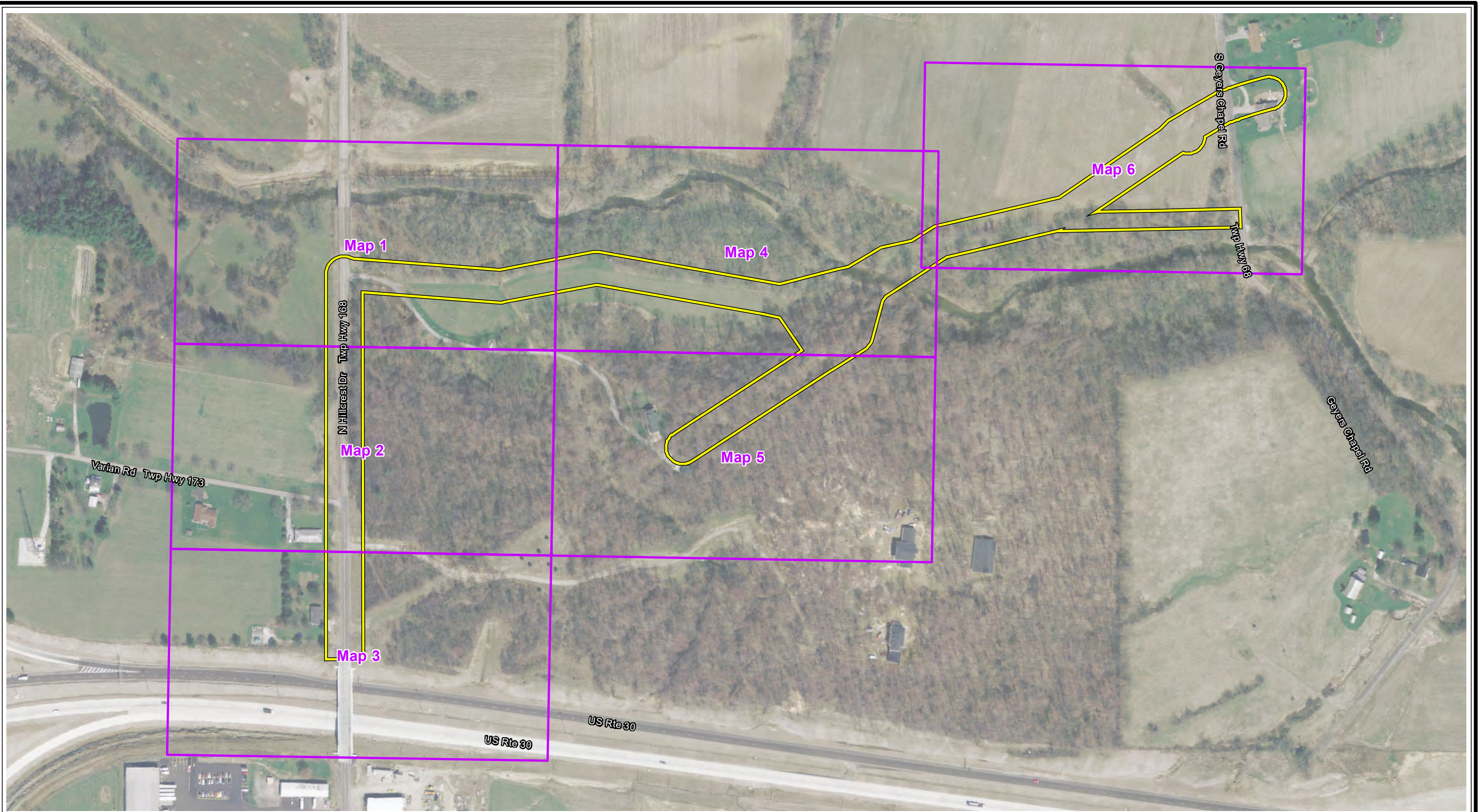


---

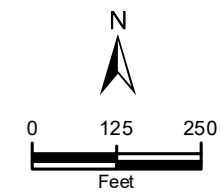
## **APPENDIX C**

# **Detailed Erosion and Sediment Control Location Drawings**





Project Study Area  
 Map Extent



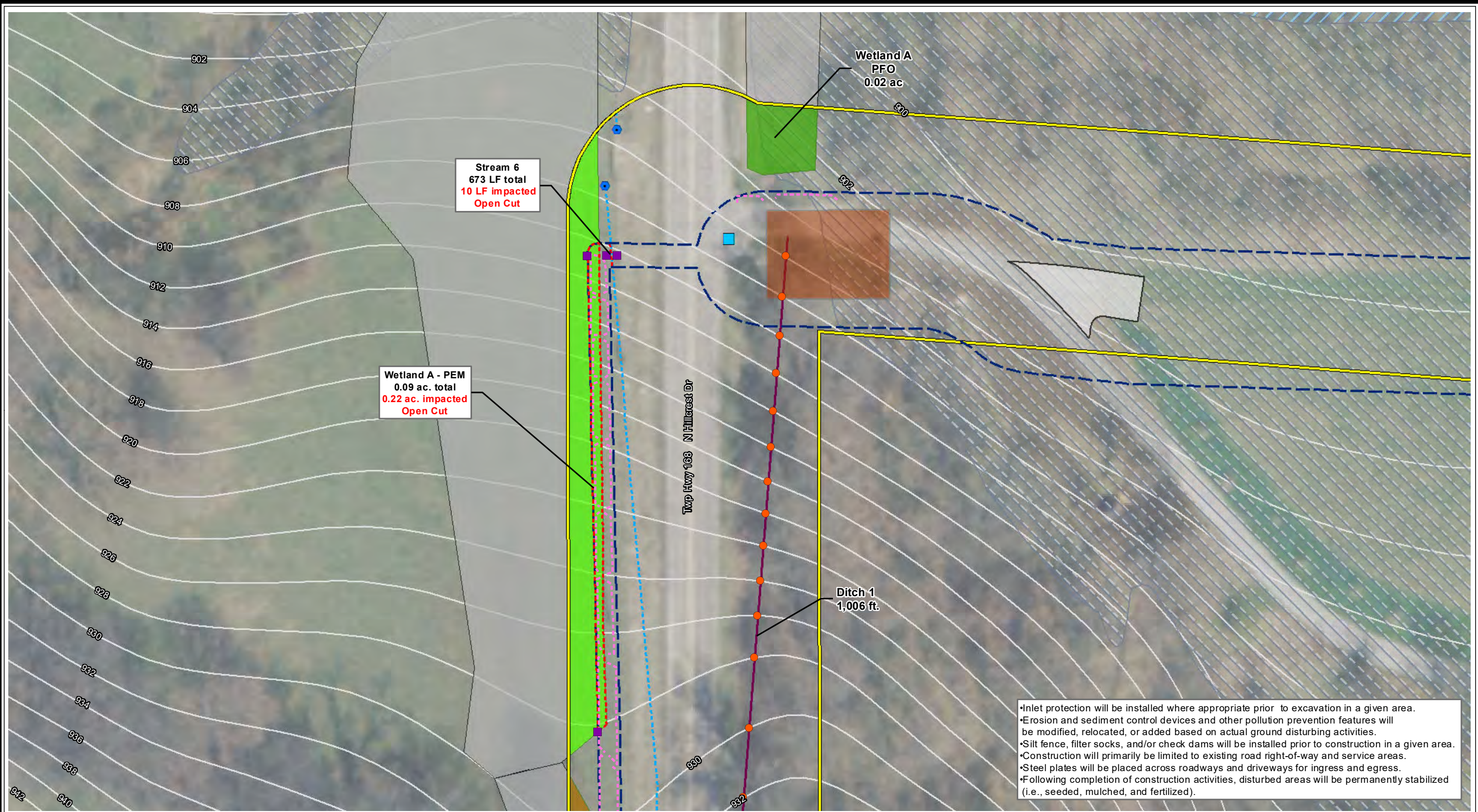
Base Layer: OSIP 2016

**Appendix C - Figure 1**  
**Erosion and Sediment Control Map Book**

PIR 2788 - Apple Creek  
 Dominion Energy Ohio  
 Wayne County, Ohio  
 Date: 1/17/2024







**Stream 6**  
673 LF total  
10 LF impacted  
Open Cut

**Wetland A - PEM**  
0.09 ac. total  
0.22 ac. impacted  
Open Cut

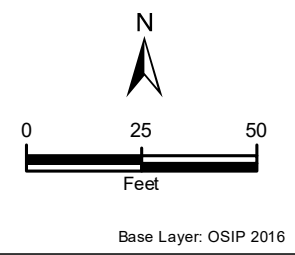
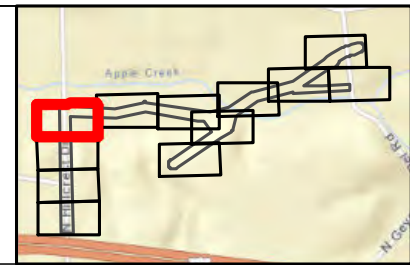
**Wetland A PFO**  
0.02 ac

**Ditch 1**  
1,006 ft.

Twp Hwy 168 N Hillcrest Dr

- Inlet protection will be installed where appropriate prior to excavation in a given area.
- Erosion and sediment control devices and other pollution prevention features will be modified, relocated, or added based on actual ground disturbing activities.
- Silt fence, filter socks, and/or check dams will be installed prior to construction in a given area.
- Construction will primarily be limited to existing road right-of-way and service areas.
- Steel plates will be placed across roadways and driveways for ingress and egress.
- Following completion of construction activities, disturbed areas will be permanently stabilized (i.e., seeded, mulched, and fertilized).

Project Study Area	Wetland Impact	Off-site Intermittent Stream	Off-Site Wetland
Work Corridor	Stormwater Inlet	On-site Ephemeral Stream	Flood Zones (FEMA)
Construction Entrance	Culvert	Off-site Ephemeral Stream	1% Annual Chance Flood Hazard
Gravel Access Road	Potential Root Tree	Delineated Ditch	Regulatory Floodway
Trench Plug	Delineated Stream	On-site Emergent Wetland	2-Foot Contour
Check Dam	On-site Perennial Stream	On-site Forested Wetland	
Filter Fence	Off-site Perennial Stream	On-site Shrub Scrub Wetland	
Stream Impact	On-site Intermittent Stream		

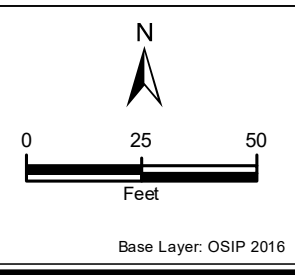
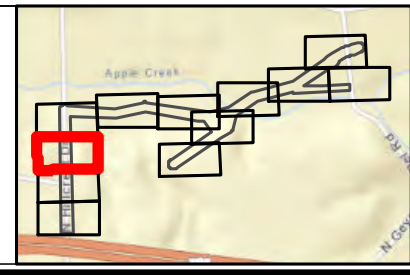
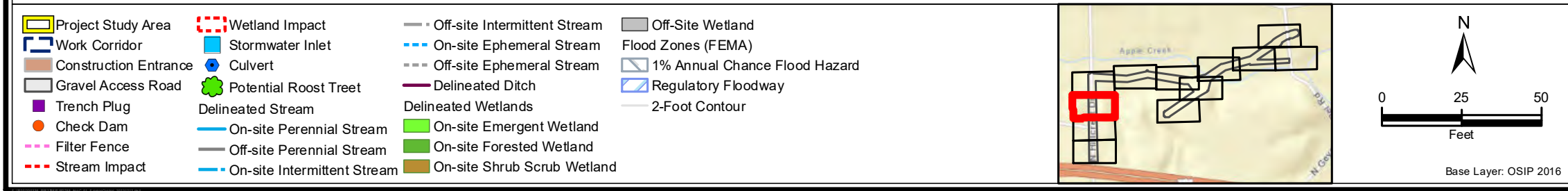
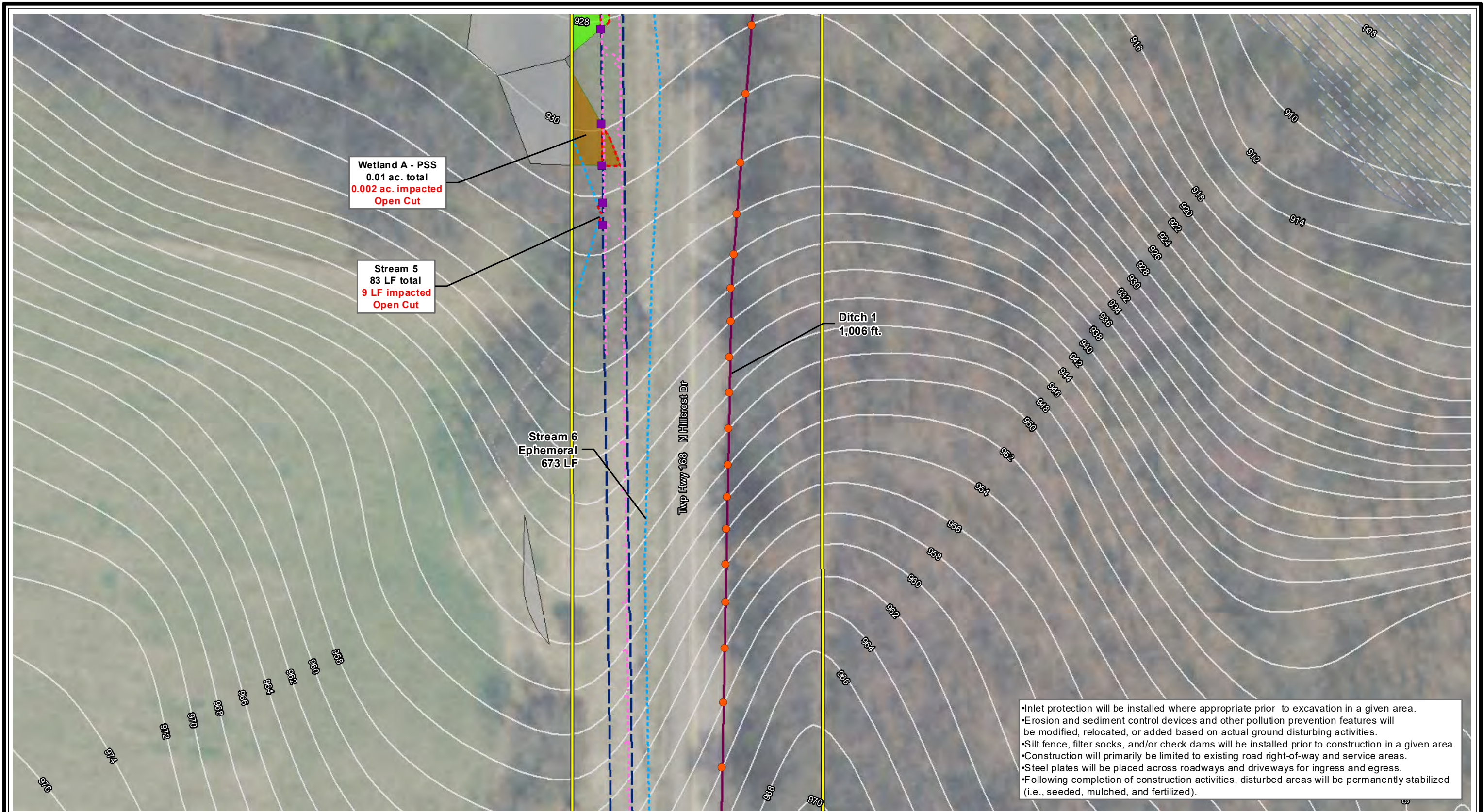


**Appendix C - Figure 1**  
**Erosion and Sediment Control Map 1 of 12**

PIR 2788 - Apple Creek  
Dominion Energy Ohio  
Wayne County, Ohio  
Date: 2/20/2024





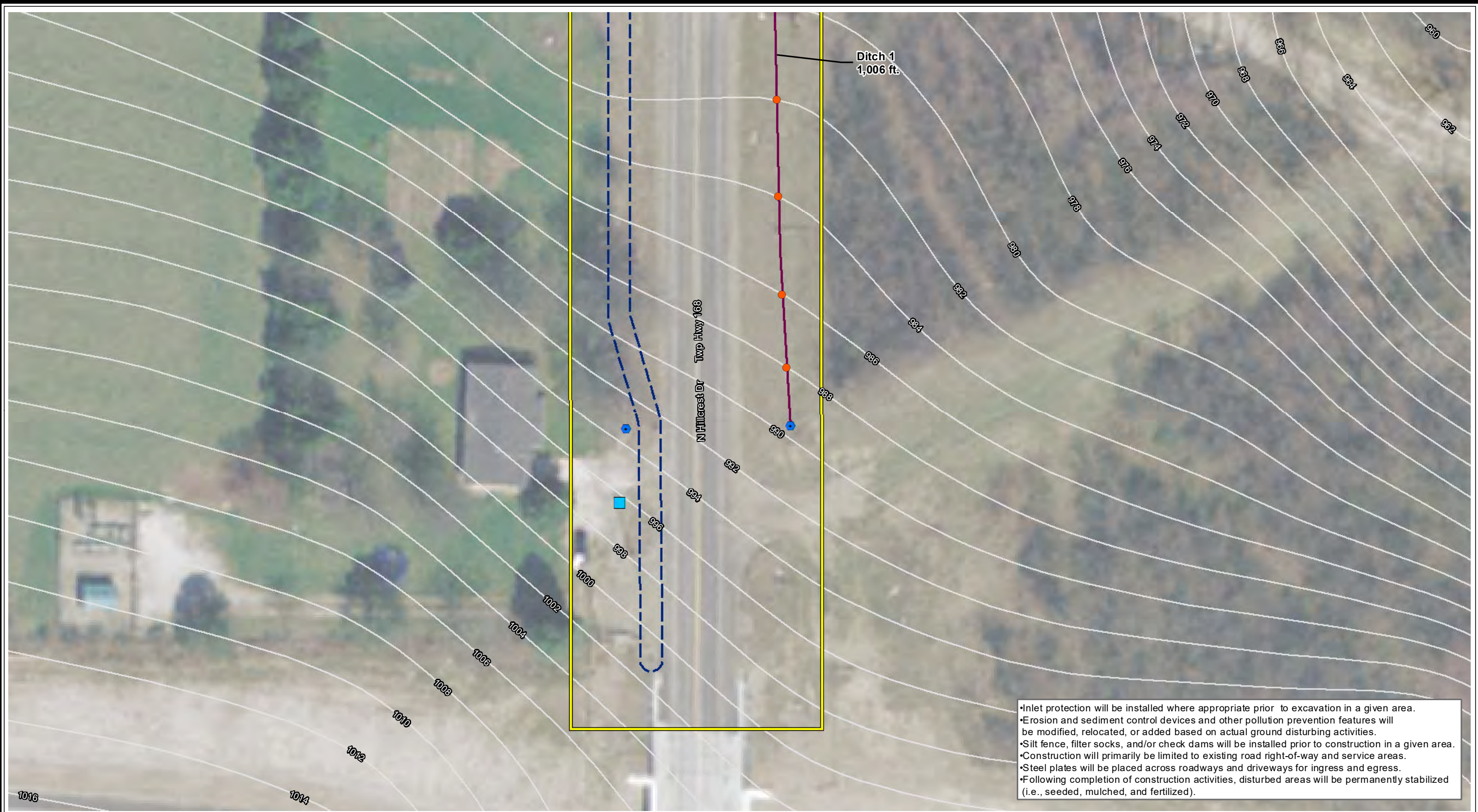


**Appendix C - Figure 1**  
**Erosion and Sediment Control Map 2 of 12**  
 PIR 2788 - Apple Creek  
 Dominion Energy Ohio  
 Wayne County, Ohio  
 Date: 2/20/2024

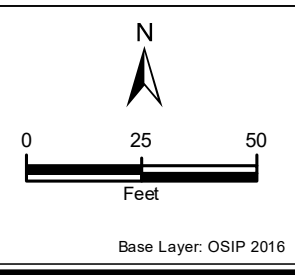
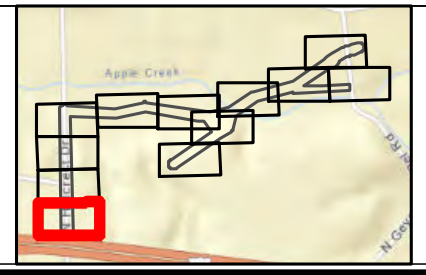








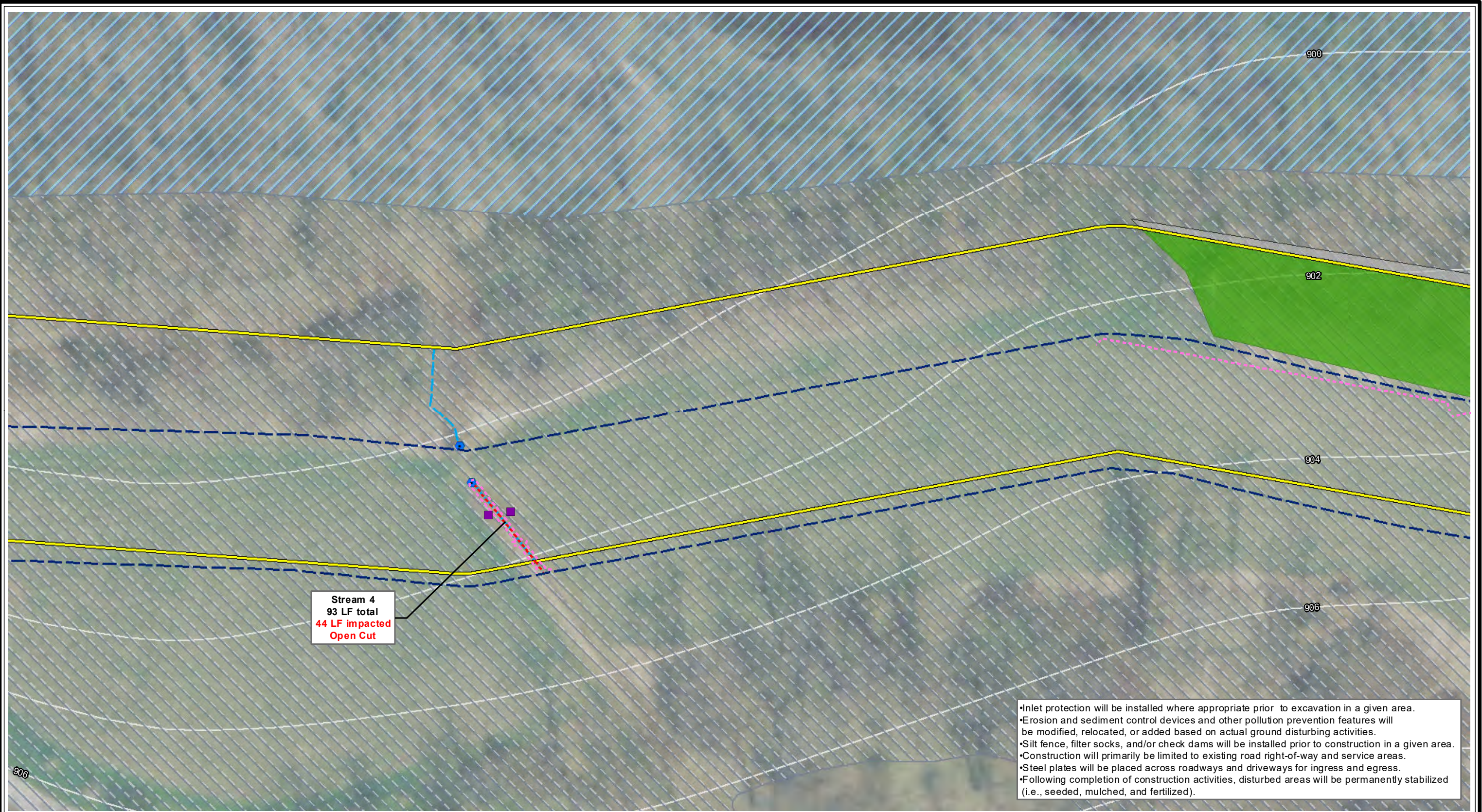
Project Study Area	Wetland Impact	Off-site Intermittent Stream	Off-Site Wetland
Work Corridor	Stormwater Inlet	On-site Ephemeral Stream	Flood Zones (FEMA)
Construction Entrance	Culvert	Off-site Ephemeral Stream	1% Annual Chance Flood Hazard
Gravel Access Road	Potential Root Tree	Delineated Ditch	Regulatory Floodway
Trench Plug	Delineated Stream	On-site Emergent Wetland	2-Foot Contour
Check Dam	On-site Perennial Stream	On-site Forested Wetland	
Filter Fence	Off-site Perennial Stream	On-site Shrub Scrub Wetland	
Stream Impact	On-site Intermittent Stream		



**Appendix C - Figure 1**  
**Erosion and Sediment Control Map 4 of 12**

PIR 2788 - Apple Creek  
 Dominion Energy Ohio  
 Wayne County, Ohio  
 Date: 2/20/2024

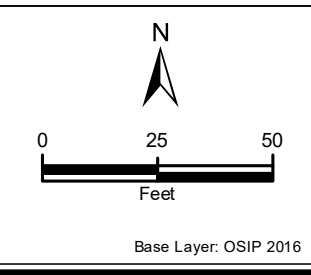
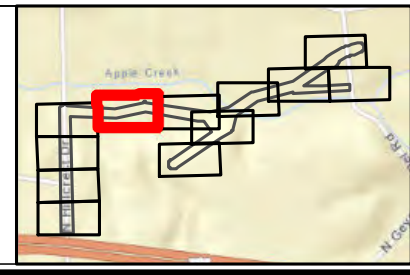




Stream 4  
93 LF total  
44 LF impacted  
Open Cut

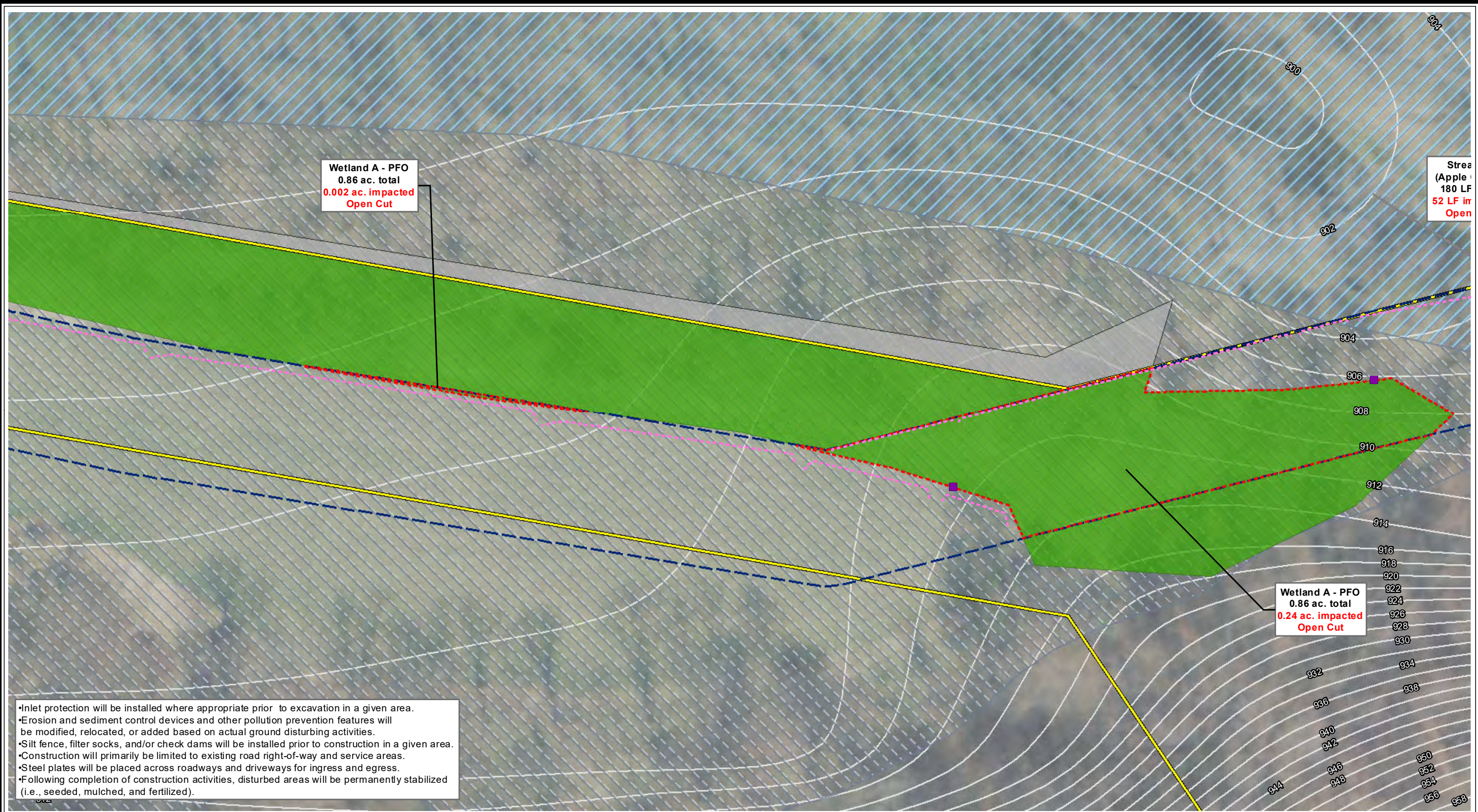
- Inlet protection will be installed where appropriate prior to excavation in a given area.
- Erosion and sediment control devices and other pollution prevention features will be modified, relocated, or added based on actual ground disturbing activities.
- Silt fence, filter socks, and/or check dams will be installed prior to construction in a given area.
- Construction will primarily be limited to existing road right-of-way and service areas.
- Steel plates will be placed across roadways and driveways for ingress and egress.
- Following completion of construction activities, disturbed areas will be permanently stabilized (i.e., seeded, mulched, and fertilized).

Project Study Area	Wetland Impact	Off-site Intermittent Stream	Off-Site Wetland
Work Corridor	Stormwater Inlet	On-site Ephemeral Stream	Flood Zones (FEMA)
Construction Entrance	Culvert	Off-site Ephemeral Stream	1% Annual Chance Flood Hazard
Gravel Access Road	Potential Root Treet	Delineated Ditch	Regulatory Floodway
Trench Plug	Delineated Stream	Delineated Wetlands	2-Foot Contour
Check Dam	On-site Perennial Stream	On-site Emergent Wetland	
Filter Fence	Off-site Perennial Stream	On-site Forested Wetland	
Stream Impact	On-site Intermittent Stream	On-site Shrub Scrub Wetland	



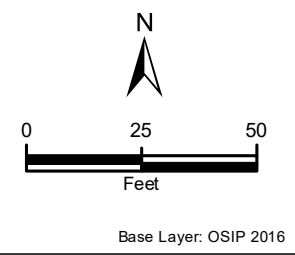
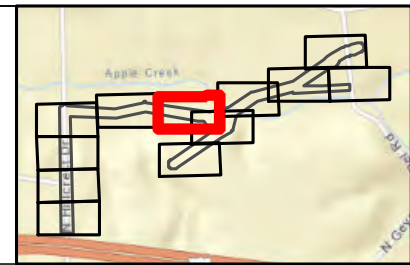
**Appendix C - Figure 1**  
**Erosion and Sediment Control Map 5 of 12**  
 PIR 2788 - Apple Creek  
 Dominion Energy Ohio  
 Wayne County, Ohio  
 Date: 2/20/2024





- Inlet protection will be installed where appropriate prior to excavation in a given area.
- Erosion and sediment control devices and other pollution prevention features will be modified, relocated, or added based on actual ground disturbing activities.
- Silt fence, filter socks, and/or check dams will be installed prior to construction in a given area.
- Construction will primarily be limited to existing road right-of-way and service areas.
- Steel plates will be placed across roadways and driveways for ingress and egress.
- Following completion of construction activities, disturbed areas will be permanently stabilized (i.e., seeded, mulched, and fertilized).

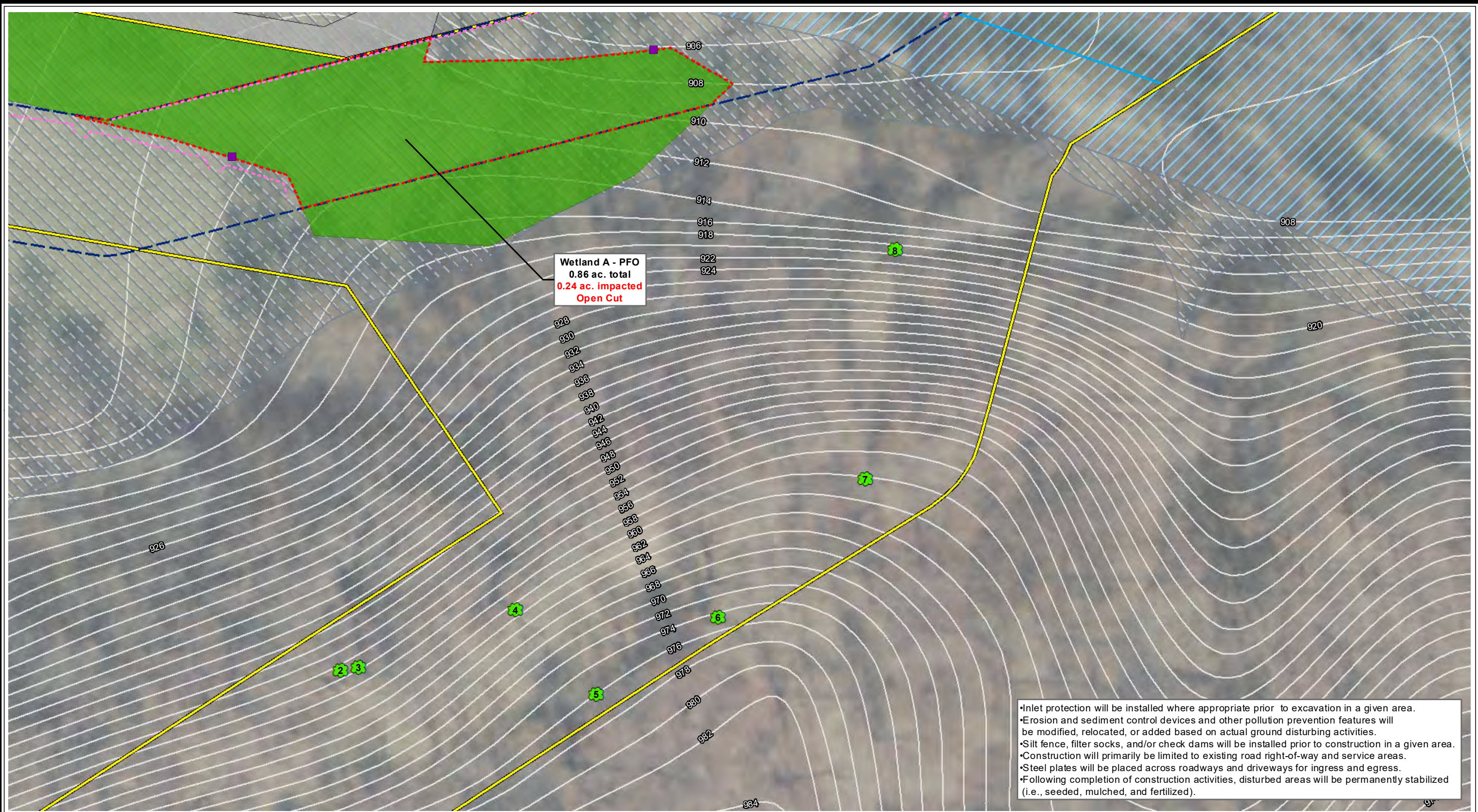
Project Study Area	Wetland Impact	Off-site Intermittent Stream	Off-Site Wetland
Work Corridor	Stormwater Inlet	On-site Ephemeral Stream	Flood Zones (FEMA)
Construction Entrance	Culvert	Off-site Ephemeral Stream	1% Annual Chance Flood Hazard
Gravel Access Road	Potential Root Tree	Delineated Ditch	Regulatory Floodway
Trench Plug	Delineated Stream	Delineated Wetlands	2-Foot Contour
Check Dam	On-site Perennial Stream	On-site Emergent Wetland	
Filter Fence	Off-site Perennial Stream	On-site Forested Wetland	
Stream Impact	On-site Intermittent Stream	On-site Shrub Scrub Wetland	



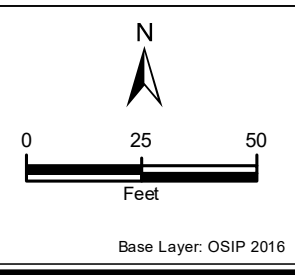
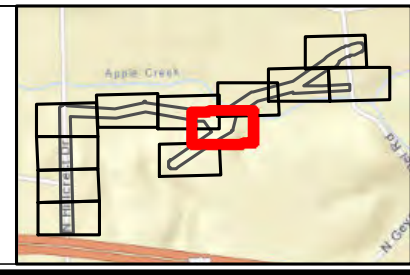
**Appendix C - Figure 1**  
**Erosion and Sediment Control Map 6 of 12**

PIR 2788 - Apple Creek  
 Dominion Energy Ohio  
 Wayne County, Ohio  
 Date: 2/20/2024





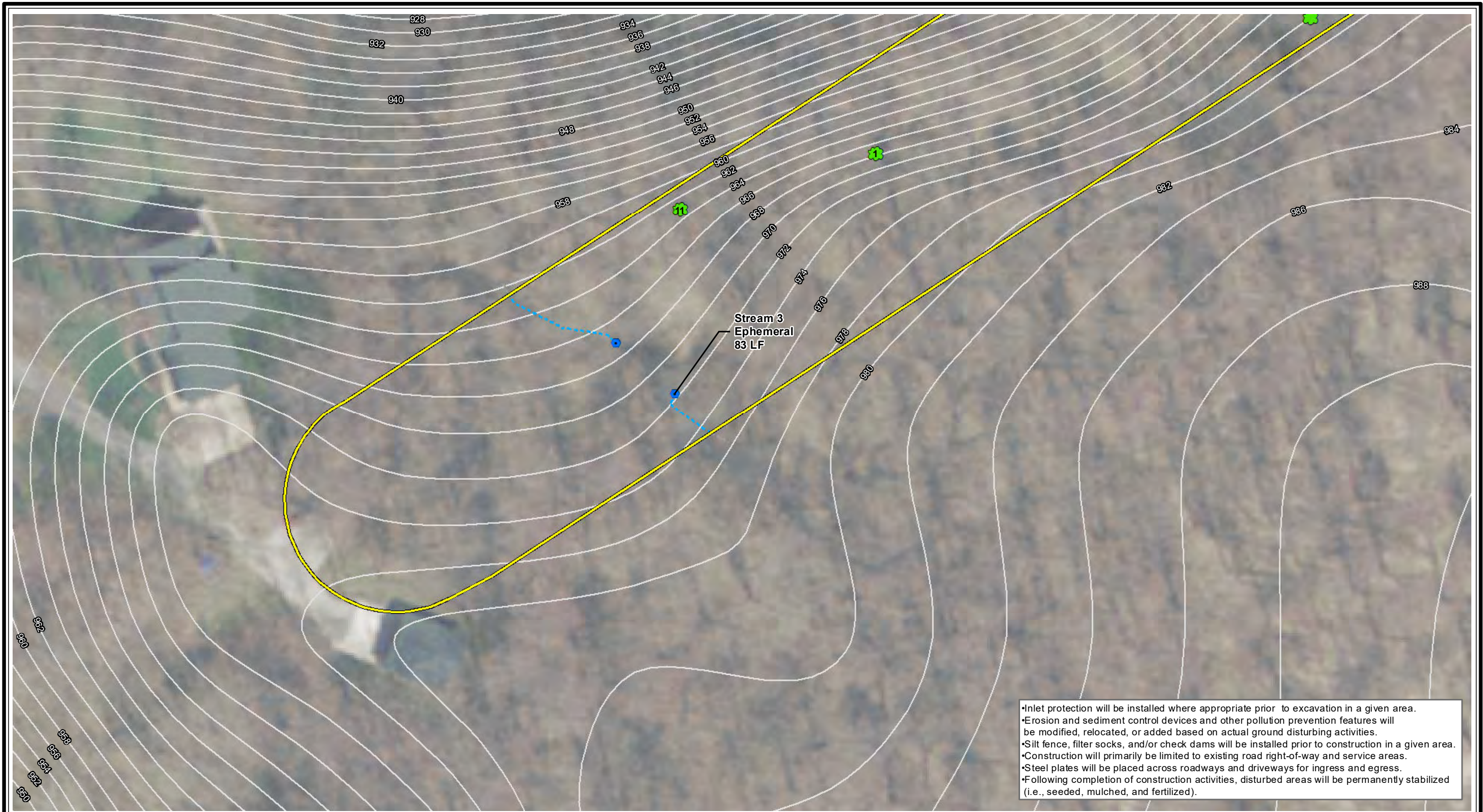
- |                       |                             |                              |                               |
|-----------------------|-----------------------------|------------------------------|-------------------------------|
| Project Study Area    | Wetland Impact              | Off-site Intermittent Stream | Off-Site Wetland              |
| Work Corridor         | Stormwater Inlet            | On-site Ephemeral Stream     | Flood Zones (FEMA)            |
| Construction Entrance | Culvert                     | Off-site Ephemeral Stream    | 1% Annual Chance Flood Hazard |
| Gravel Access Road    | Potential Roost Tree        | Delineated Ditch             | Regulatory Floodway           |
| Trench Plug           | Delineated Stream           | Delineated Wetlands          | 2-Foot Contour                |
| Check Dam             | On-site Perennial Stream    | On-site Emergent Wetland     |                               |
| Filter Fence          | Off-site Perennial Stream   | On-site Forested Wetland     |                               |
| Stream Impact         | On-site Intermittent Stream | On-site Shrub Scrub Wetland  |                               |



**Appendix C - Figure 1**  
**Erosion and Sediment Control Map 7 of 12**


PIR 2788 - Apple Creek  
 Dominion Energy Ohio  
 Wayne County, Ohio  
 Date: 2/20/2024






- Inlet protection will be installed where appropriate prior to excavation in a given area.
- Erosion and sediment control devices and other pollution prevention features will be modified, relocated, or added based on actual ground disturbing activities.
- Silt fence, filter socks, and/or check dams will be installed prior to construction in a given area.
- Construction will primarily be limited to existing road right-of-way and service areas.
- Steel plates will be placed across roadways and driveways for ingress and egress.
- Following completion of construction activities, disturbed areas will be permanently stabilized (i.e., seeded, mulched, and fertilized).

<ul style="list-style-type: none"> <li>Project Study Area</li> <li>Work Corridor</li> <li>Construction Entrance</li> <li>Gravel Access Road</li> <li>Trench Plug</li> <li>Check Dam</li> <li>Filter Fence</li> <li>Stream Impact</li> </ul>	<ul style="list-style-type: none"> <li>Wetland Impact</li> <li>Stormwater Inlet</li> <li>Culvert</li> <li>Potential Roost Tree</li> <li>Delineated Stream</li> <li>On-site Perennial Stream</li> <li>Off-site Perennial Stream</li> <li>On-site Intermittent Stream</li> </ul>	<ul style="list-style-type: none"> <li>Off-site Intermittent Stream</li> <li>On-site Ephemeral Stream</li> <li>Off-site Ephemeral Stream</li> <li>Delineated Ditch</li> <li>Delineated Wetlands</li> <li>On-site Emergent Wetland</li> <li>On-site Forested Wetland</li> <li>On-site Shrub Scrub Wetland</li> </ul>	<ul style="list-style-type: none"> <li>Off-Site Wetland</li> <li>Flood Zones (FEMA)</li> <li>1% Annual Chance Flood Hazard</li> <li>Regulatory Floodway</li> <li>2-Foot Contour</li> </ul>
---	--	---	--



N



25


50

Feet

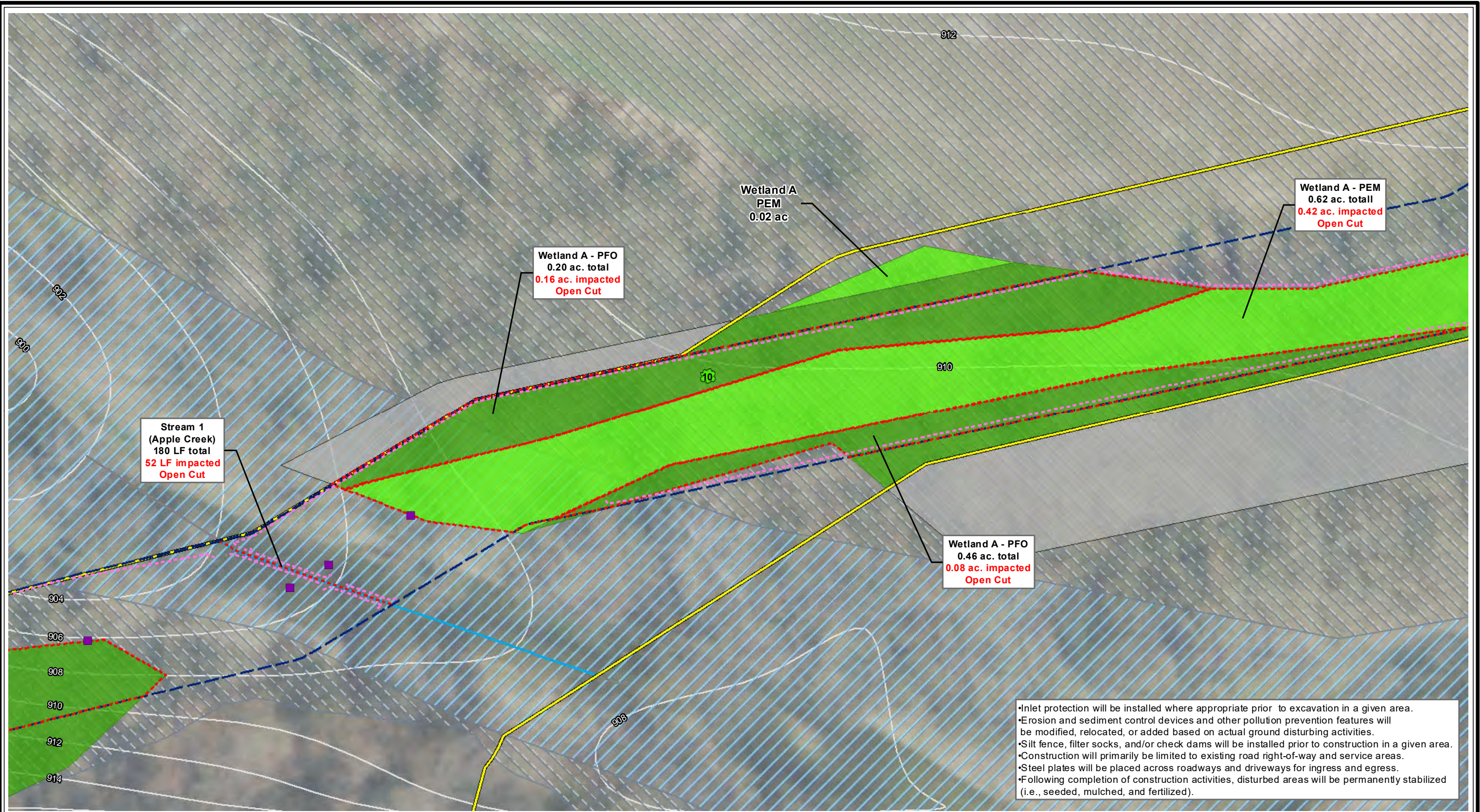
Base Layer: OSIP 2016

**Appendix C - Figure 1**  
**Erosion and Sediment Control Map 8 of 12**

PIR 2788 - Apple Creek  
 Dominion Energy Ohio  
 Wayne County, Ohio  
 Date: 2/20/2024







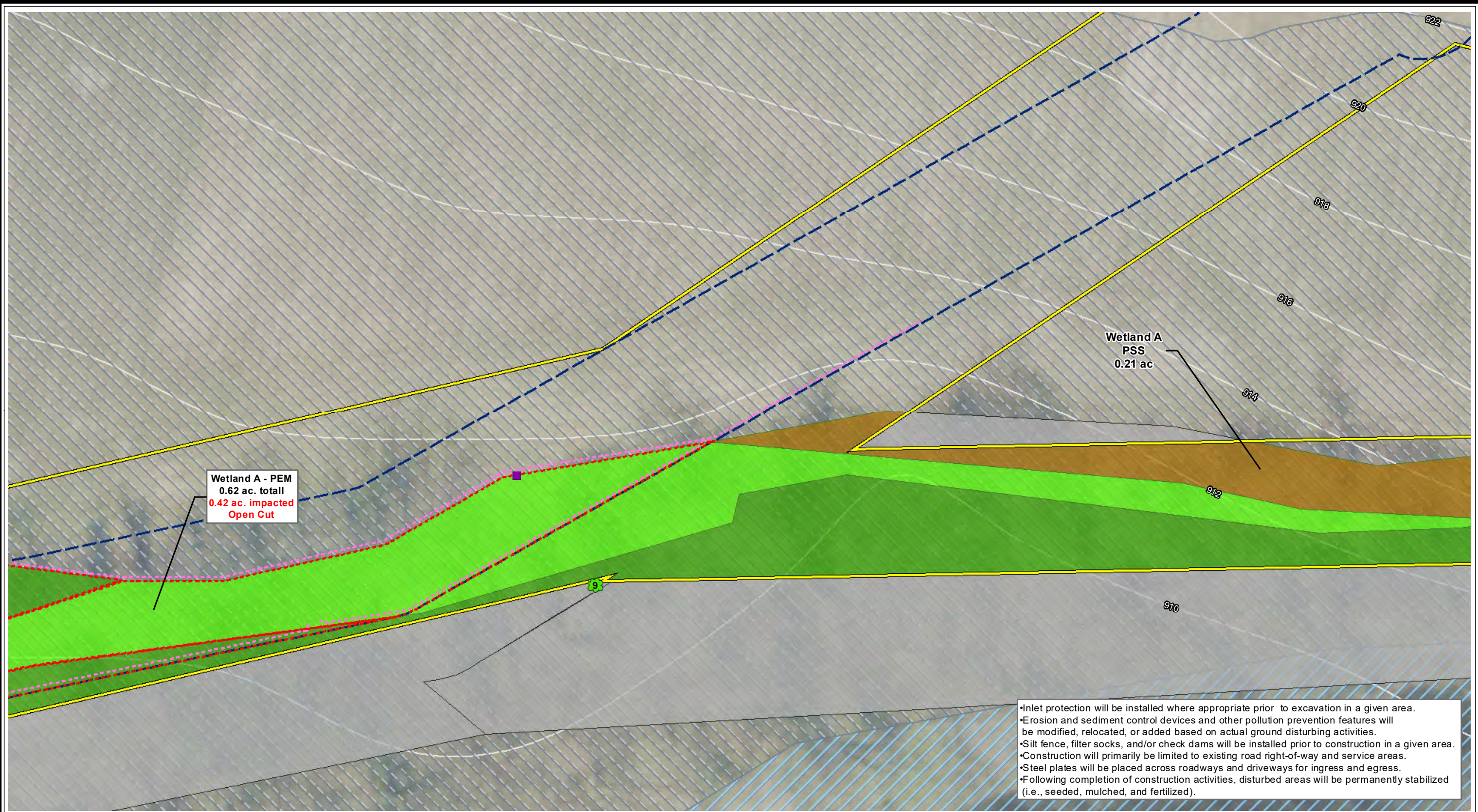
Project Study Area	Wetland Impact	Off-site Intermittent Stream	Off-Site Wetland
Work Corridor	Stormwater Inlet	On-site Ephemeral Stream	Flood Zones (FEMA)
Construction Entrance	Culvert	Off-site Ephemeral Stream	1% Annual Chance Flood Hazard
Gravel Access Road	Potential Roost Tree	Delineated Ditch	Regulatory Floodway
Trench Plug	<b>Delineated Stream</b>	<b>Delineated Wetlands</b>	2-Foot Contour
Check Dam	On-site Perennial Stream	On-site Emergent Wetland	
Filter Fence	Off-site Perennial Stream	On-site Forested Wetland	
Stream Impact	On-site Intermittent Stream	On-site Shrub Scrub Wetland	

Base Layer: OSIP 2016

**Appendix C - Figure 1**  
**Erosion and Sediment Control Map 9 of 12**

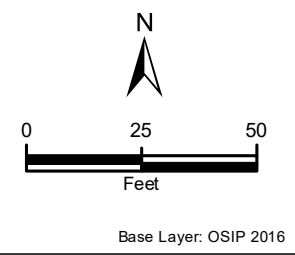
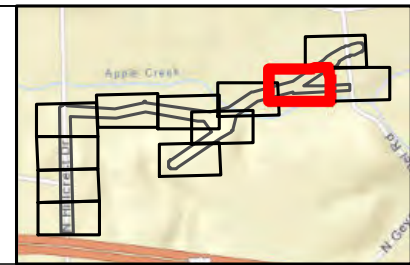
PIR 2788 - Apple Creek  
Dominion Energy Ohio  
Wayne County, Ohio  
Date: 2/20/2024





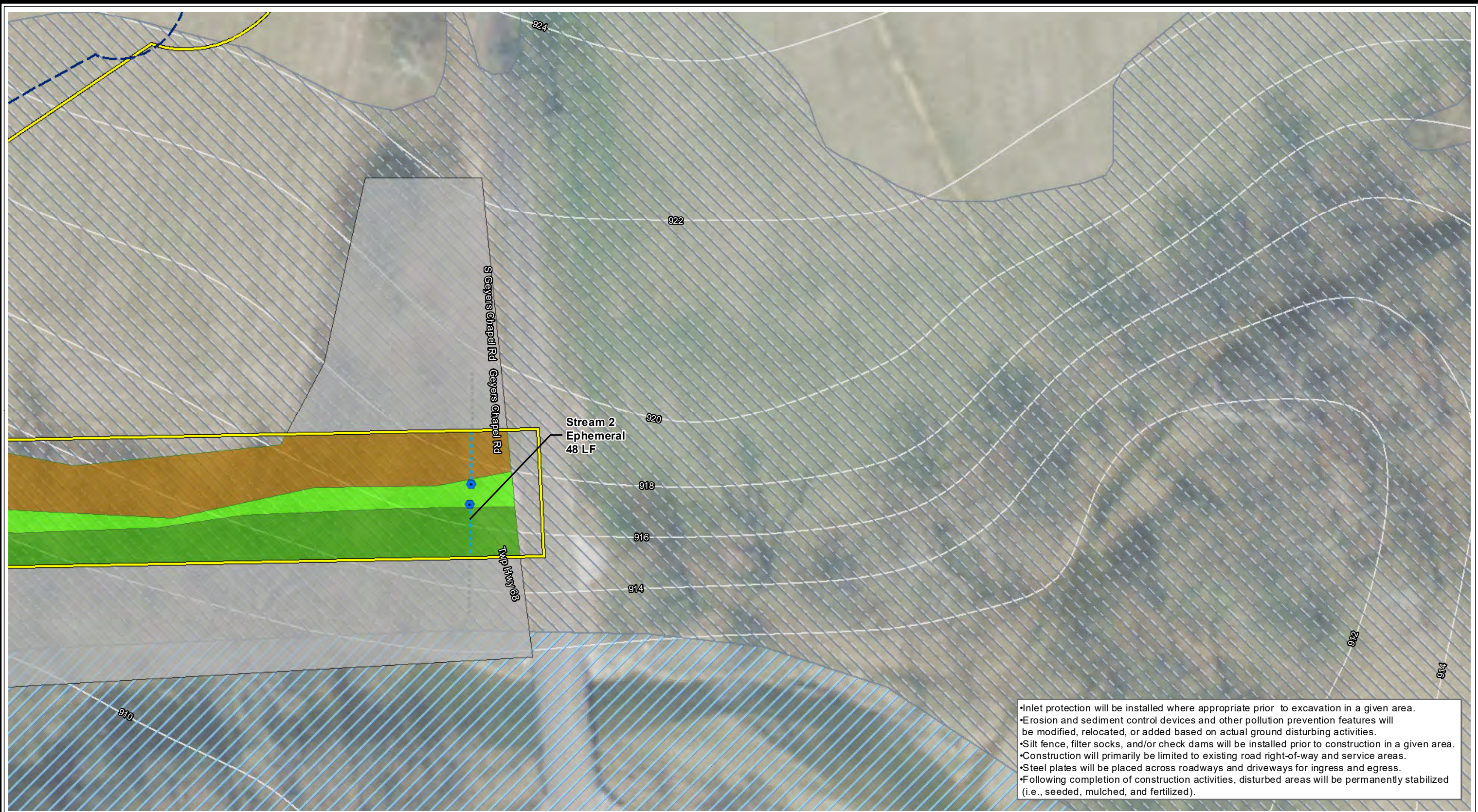
- Inlet protection will be installed where appropriate prior to excavation in a given area.
- Erosion and sediment control devices and other pollution prevention features will be modified, relocated, or added based on actual ground disturbing activities.
- Silt fence, filter socks, and/or check dams will be installed prior to construction in a given area.
- Construction will primarily be limited to existing road right-of-way and service areas.
- Steel plates will be placed across roadways and driveways for ingress and egress.
- Following completion of construction activities, disturbed areas will be permanently stabilized (i.e., seeded, mulched, and fertilized).

Project Study Area	Wetland Impact	Off-site Intermittent Stream	Off-Site Wetland
Work Corridor	Stormwater Inlet	On-site Ephemeral Stream	Flood Zones (FEMA)
Construction Entrance	Culvert	Off-site Ephemeral Stream	1% Annual Chance Flood Hazard
Gravel Access Road	Potential Roost Tree	Delineated Ditch	Regulatory Floodway
Trench Plug	Delineated Stream	Delineated Wetlands	2-Foot Contour
Check Dam	On-site Perennial Stream	On-site Emergent Wetland	
Filter Fence	Off-site Perennial Stream	On-site Forested Wetland	
Stream Impact	On-site Intermittent Stream	On-site Shrub Scrub Wetland	

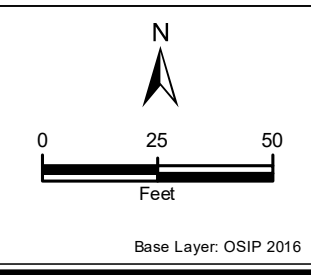
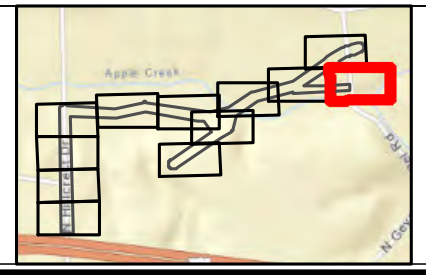


**Appendix C - Figure 1**  
**Erosion and Sediment Control Map 10 of 12**  
 PIR 2788 - Apple Creek  
 Dominion Energy Ohio  
 Wayne County, Ohio  
 Date: 2/20/2024





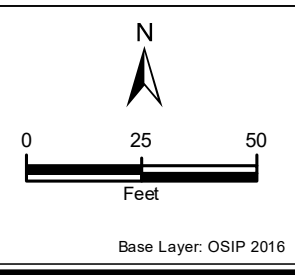
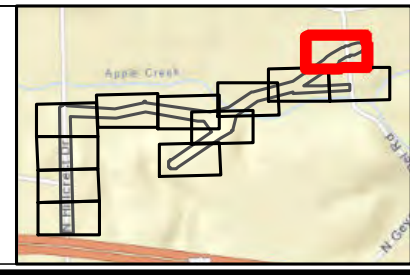
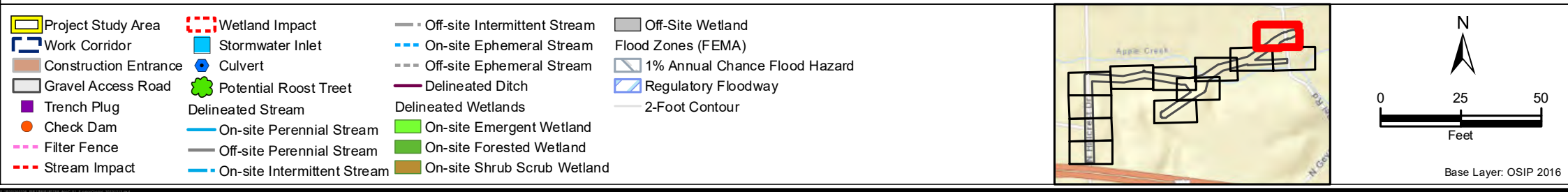
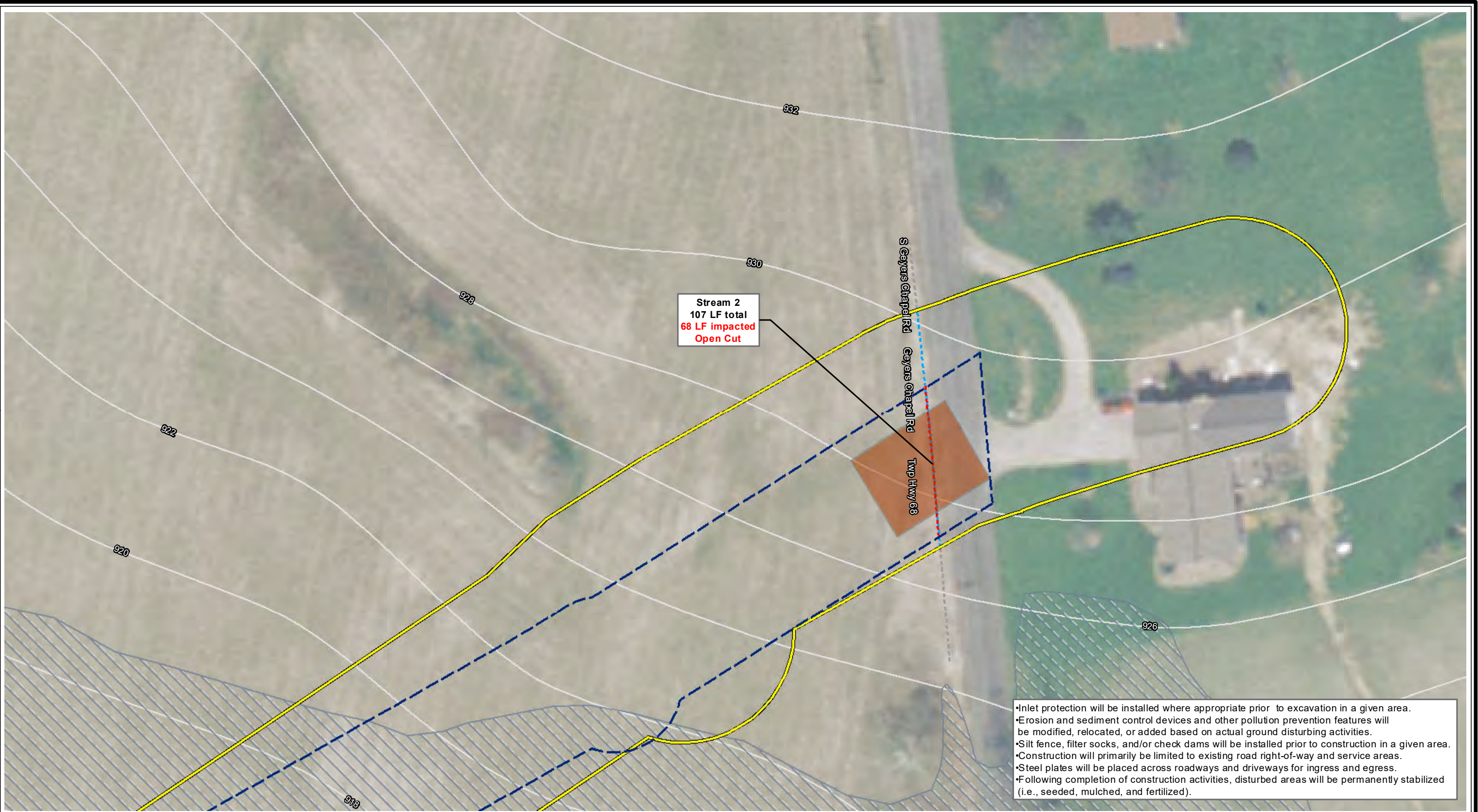
Project Study Area	Wetland Impact	Off-site Intermittent Stream	Off-Site Wetland
Work Corridor	Stormwater Inlet	On-site Ephemeral Stream	Flood Zones (FEMA)
Construction Entrance	Culvert	Off-site Ephemeral Stream	1% Annual Chance Flood Hazard
Gravel Access Road	Potential Root Tree	Delineated Ditch	Regulatory Floodway
Trench Plug	Delineated Stream	Delineated Wetlands	2-Foot Contour
Check Dam	On-site Perennial Stream	On-site Emergent Wetland	
Filter Fence	Off-site Perennial Stream	On-site Forested Wetland	
Stream Impact	On-site Intermittent Stream	On-site Shrub Scrub Wetland	



**Appendix C - Figure 1**  
**Erosion and Sediment Control Map 11 of 12**

PIR 2788 - Apple Creek  
 Dominion Energy Ohio  
 Wayne County, Ohio  
 Date: 2/20/2024





**Appendix C - Figure 1**  
**Erosion and Sediment Control Map 12 of 12**

PIR 2788 - Apple Creek  
Dominion Energy Ohio  
Wayne County, Ohio  
Date: 2/20/2024



---

## **APPENDIX D**

### **Site Drawing Checklist and Logs**

## **D-1 SITE DRAWING CHECKLIST \*\***

- **Location of solid waste dumpsters**
- **Location designated for waste drums of oil soaked absorbent pads/rags; solids, sludge, or oil collected from pipeline**
- **Locations of sanitary facilities such as Port-a-Jons (update these locations on drawings as project progresses)**
- **Locations of diesel and gasoline storage tanks (secondary containment provided)**
- **Locations of pipe and equipment storage yards**
- **Locations of cement truck washout**

**\*\* *These locations can be hand drawn on the site drawings.***

**SWPPP Amendment Log**

D-2

**Project Name:** \_\_\_\_\_

**Construction Inspector:** \_\_\_\_\_

<b>Amendment Number</b>	<b>Description of Amendment</b>	<b>Date of Amendment</b>	<b>Amendment Prepared by (name and title)</b>





---

## **APPENDIX E**

### **Corrective Action Log**



**Dominion Construction Stormwater General Permit: Corrective Action Log**

**Project Name:**

**State-Specific Corrective Action Requirement\*:**

**Positions Authorized to Document Corrective Action Completion:**

Corrective Action #	Inspection Date	Inspector Name(s)	Description of Deficiency	Corrective Action Required	Date Corrective Action is Due*	Agency Notification Required? (Y/N)	Date Corrective Action Performed / Responsible Person

\*Corrective action requirements/deadlines are state specific. Thus, refer to your construction stormwater permit. Should the project team not be able to meet the permit deadlines then the stormwater management program authority (e.g. state agency) must be notified.



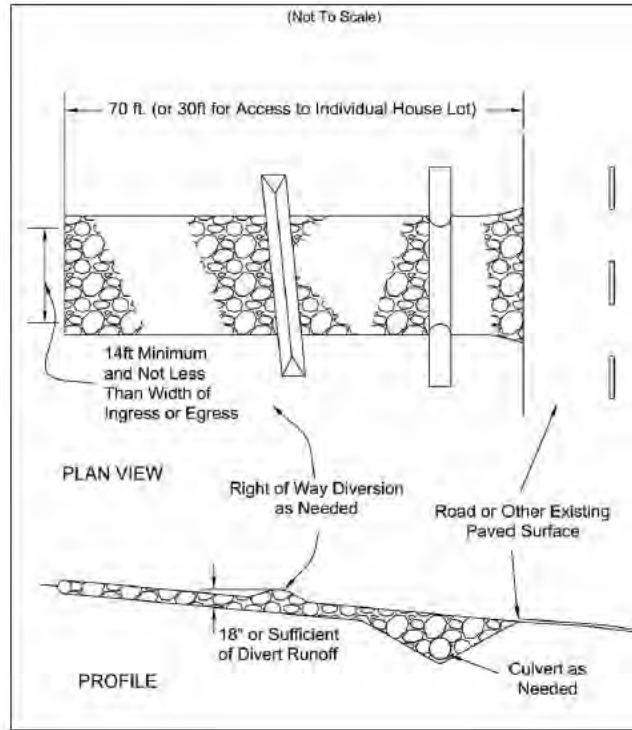
---

## **APPENDIX F**

# **Typical Upland Erosion and Sediment Control Plan Drawings**

# DETAIL F-1

## ROCK CONSTRUCTION ENTRANCE DETAIL



Specifications  
for

### Construction Entrance

1. Stone Size—ODOT # 2 (1.5-2.5 inch) stone shall be used, or recycled concrete equivalent.
2. Length—The Construction entrance shall be as long as required to stabilize high traffic areas but not less than 70 ft. (exception: apply 30 ft. minimum to single residence lots).
3. Thickness -The stone layer shall be at least 6 inches thick for light duty entrances or at least 10 inches for heavy duty use.
4. Width -The entrance shall be at least 14 feet wide, but not less than the full width at points where ingress or egress occurs.
5. Geotextile -A geotextile shall be laid over the entire area prior to placing stone. It shall be composed of strong rot-proof polymeric fibers and meet the following specifications:
6. Timing—The construction entrance shall be installed as soon as is practicable before major grading activities.
7. Culvert -A pipe or culvert shall be constructed under the entrance if needed to prevent surface water from flowing across the entrance or to prevent runoff from being directed out onto paved surfaces.
8. Water Bar -A water bar shall be constructed as part of the construction entrance if needed to prevent surface runoff from flowing the length of the construction entrance and out onto paved surfaces.
9. Maintenance -Top dressing of additional stone shall be applied as conditions demand. Mud spilled, dropped, washed or tracked onto public roads, or any surface where runoff is not checked by sediment controls, shall be removed immediately. Removal shall be accomplished by scraping or sweeping.
10. Construction entrances shall not be relied upon to remove mud from vehicles and prevent off-site tracking. Vehicles that enter and leave the construction-site shall be restricted from muddy areas.
11. Removal—the entrance shall remain in place until the disturbed area is stabilized or replaced with a permanent roadway or entrance.

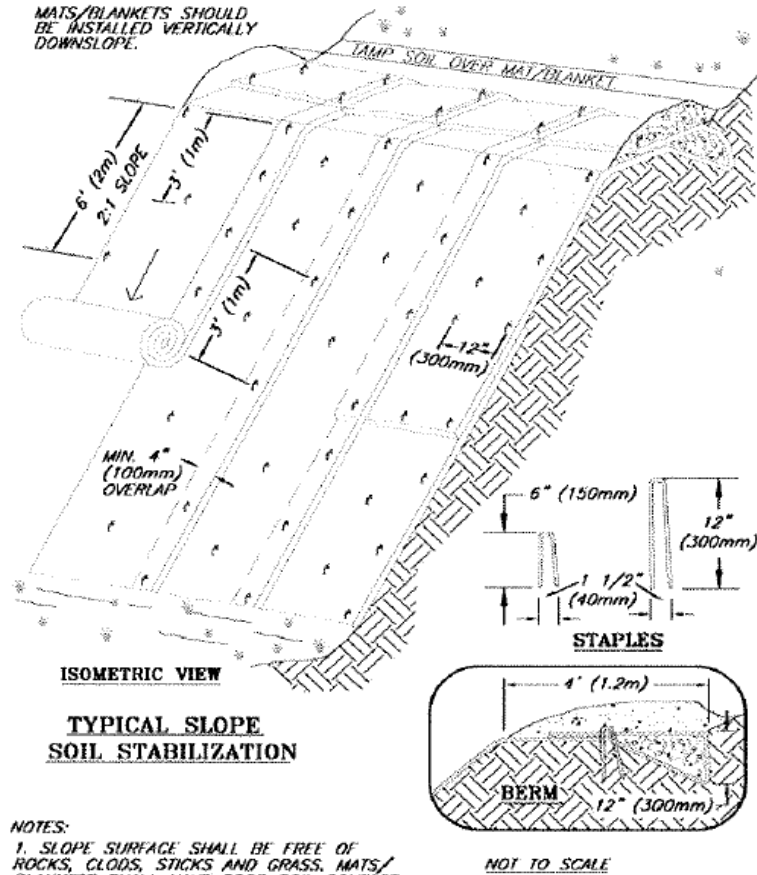
Figure 7.4.1

Geotextile Specification for Construction Entrance	
Minimum Tensile Strength	200 lbs.
Minimum Puncture Strength	80 psi.
Minimum Tear Strength	50 lbs.
Minimum Burst Strength	320 psi.
Minimum Elongation	20%
Equivalent Opening Size	EOS < 0.6 mm.
Permittivity	1×10 <sup>-3</sup> cm/sec.

# DETAIL F-2

## EROSION CONTROL MATTING DETAIL

### EROSION CONTROL BLANKET DETAIL



**NOTES:**

1. SLOPE SURFACE SHALL BE FREE OF ROCKS, CLODS, STICKS AND GRASS. MATS/BLANKETS SHALL HAVE GOOD SOIL CONTACT.
2. APPLY PERMANENT SEEDING BEFORE PLACING BLANKETS.
3. LAY BLANKETS LOOSELY AND STAKE OR STAPLE TO MAINTAIN DIRECT CONTACT WITH THE SOIL. DO NOT STRETCH.

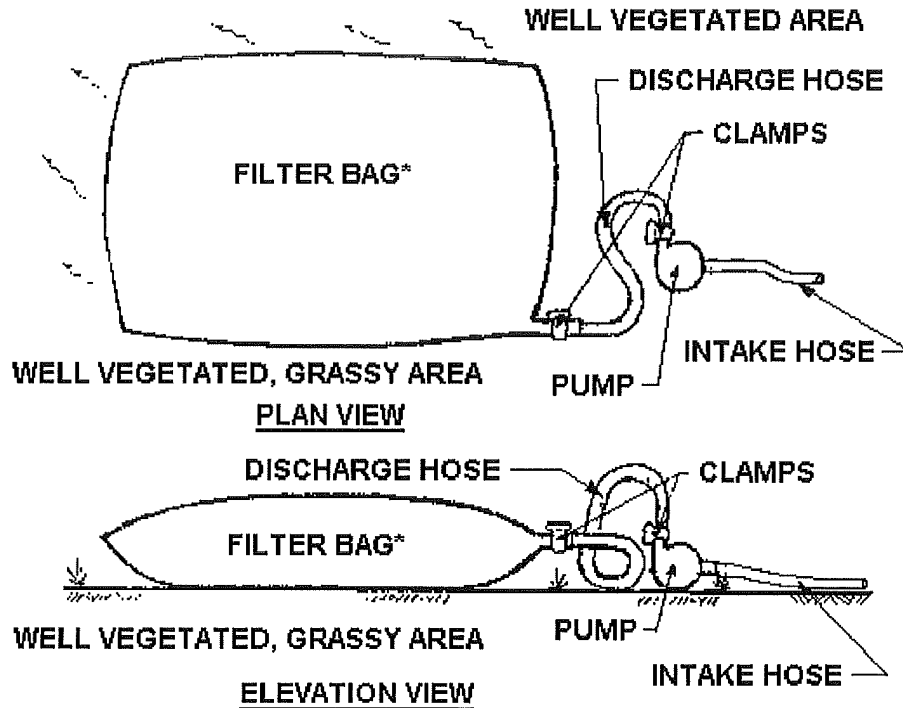
**EROSION BLANKETS &  
TURF REINFORCEMENT MATS  
SLOPE INSTALLATION**

Refer to manufacturer's lining installation detail for overlap, embedment, staple patterns, and vegetative stabilization specifications



## DETAIL F-3

### PUMPED WATER FILTER BAG DETAIL



Filter bags shall be made from non-woven geotextile material sewn with high strength, double stitched "J" type seams. They shall be capable of trapping particles larger than 150 microns.

A suitable means of accessing the bag with machinery required for disposal purposes must be provided. Filter bags shall be replaced when they become 1/2 full. Spare bags shall be kept available for replacement of those that have failed or are filled.

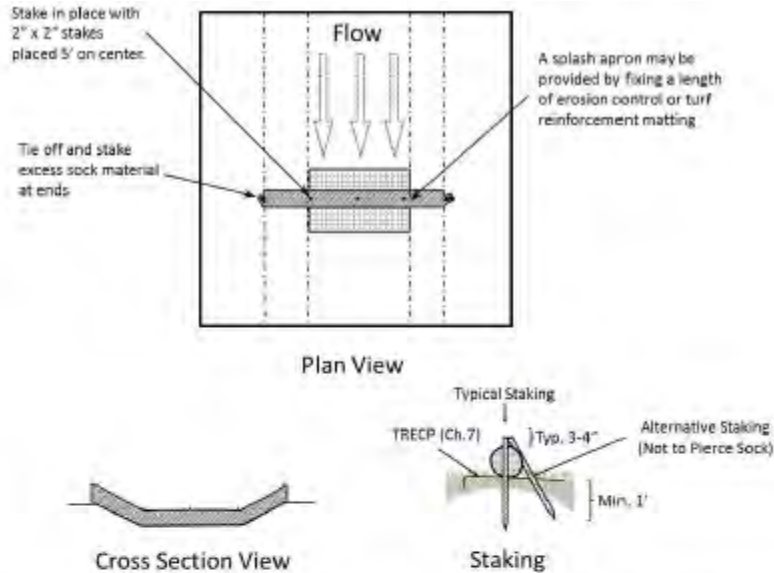
Bags shall be located in a well-vegetated (grassy) area, and discharge onto stable, erosion resistant areas. Where this is not possible, a geotextile flow path shall be provided. Bags should not be placed on slopes greater than 5%.

For hydrostatic discharge, the pumping rate is 350-500 gallons per minute (gpm). For trench dewatering, the pumping rate shall be no more than 750 gpm. Floating pump intakes should be considered to allow sediment-free water to be discharged during dewatering.

Filter bags shall be inspected daily. If any problem is detected, pumping shall cease immediately and not resume until the problem is corrected.

# DETAIL F-4

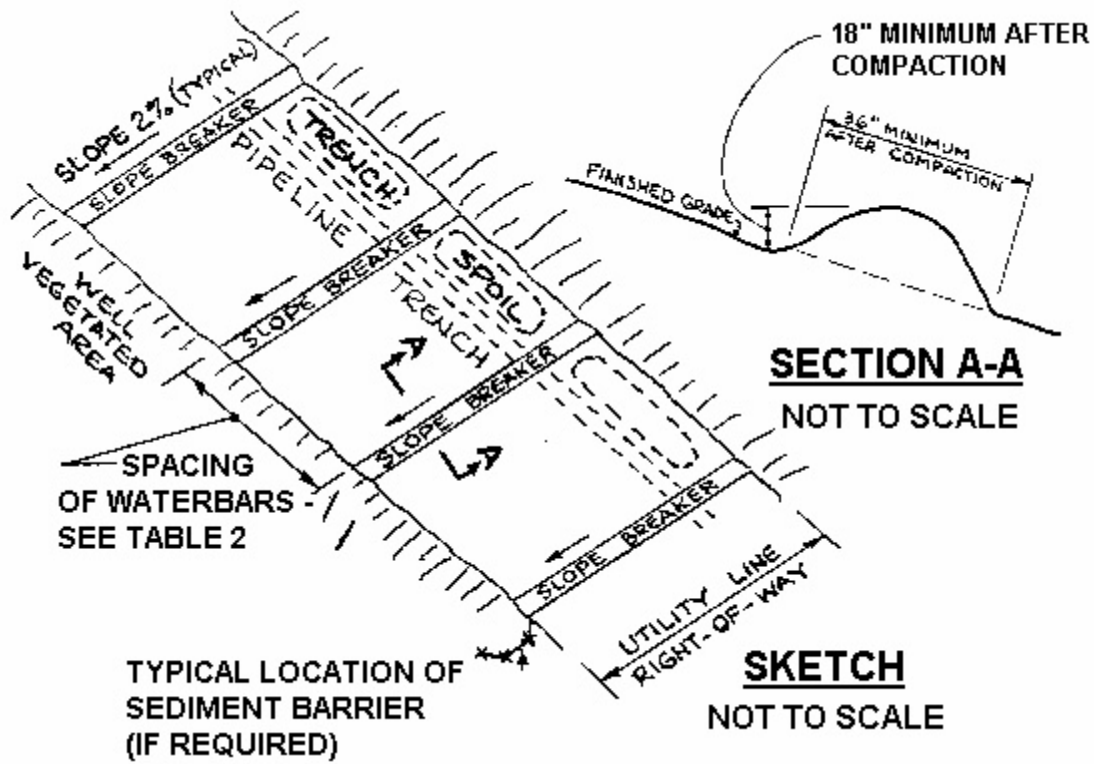
## COMPOST SOCK CHECK DAM DETAIL



1. Compost sock netting shall use a knitted mesh fabric with 1/8-3/8 inch openings, and compost media with particle sizes 99% < 3 inches, and 60% > 3/8 inches (conforming to media described in Chapter 6 Filter Sock).
2. Compost sock check dams shall be used in areas that drain 5 acres or less.
3. Sediment shall be removed from behind the sock when it reaches 1/2 the height of the check dam.
4. Compost sock check dams shall be constructed with 12, 18, or 24 in diameter compost socks, and shall completely cover the width of the channel. The midpoint of the compost sock check dam shall be a minimum of 6 inches lower than the sides in order to direct flow across the center and away from the channel sides. Filter sock check dams shall be filled to a density such that they shall reach their intended height (diameter). After installation and use, they shall be considered unsuitable and in need of replacement after falling below 80% of their minimum required height (diameter).
5. Although no trenching is necessary, compost sock check dams shall be placed on a graded surface where consistent contact with the soil surface is made without bridging over gaps, rills, gullies, stones or other irregularities.
6. Place compost sock check dams so that the ends extend to the top of bank. Staking for compost sock check dams shall use 2 inch x 2 inch wooden stakes, placed 5 foot on center. Stake length shall allow them to be driven 12 inches into existing soil and allow at least 2 inches above the sock.
7. Space compost sock check dams so that the toe of the upstream dam is at the same elevation or lower elevation as the top of the downstream compost sock check dam (at the center of the channel). This will be influenced by the height of the sock and gradient of the waterway.
8. A splash apron may be needed where flows over the sock may erode the channel and undercut the compost sock check dam. Create the apron by fixing a length of Temporary Rolled Erosion Control Product (Erosion Control Matting) or Turf Reinforcement Matting starting upstream of the sock a distance equal to the sock height and extending a length two times the height of the compost sock check dam. See Chapter 7 for information regarding these materials. Materials used should be able to be left in place (e.g. biodegradable/photodegradable TRECP) without creating problems for future mowing or maintenance of the channel.

# DETAIL F-5

## WATERBAR INSTALLATION



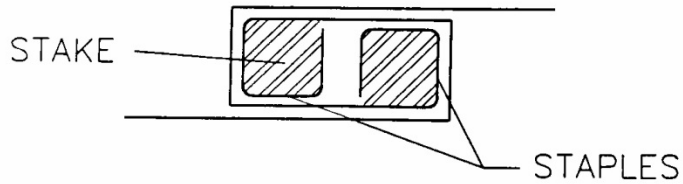
Required Spacing for Temporary and Permanent Waterbars	
Percent Slope	Spacing (FT)
1	400
2	250
5	135
10	80
15	60
20	45

Waterbars should be constructed at a slope of 1% and discharge to a well-vegetated area. Waterbars should not discharge into an open trench. Waterbars should be oriented so that the discharge does not flow back onto the ROW. Obstructions, (e.g. silt fence, rock filters, etc.) should not be placed in any waterbars. Where needed, they should be located below the discharge end of the waterbar.

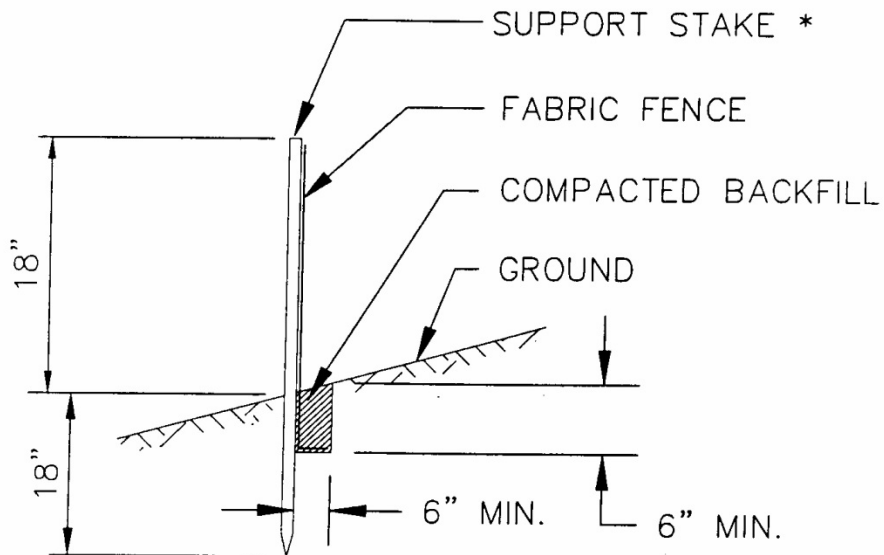


## DETAIL F-6

### FILTER FABRIC FENCE DETAIL



### JOINING FENCE SECTIONS



\*Stakes spaced @ 8' maximum. Use 2"x 2" wood or equivalent steel stakes.

Filter Fabric Fence must be placed at level existing grade. Both ends of the barrier must be extended at least 8 feet up slope at 45 degrees to the main barrier alignment.

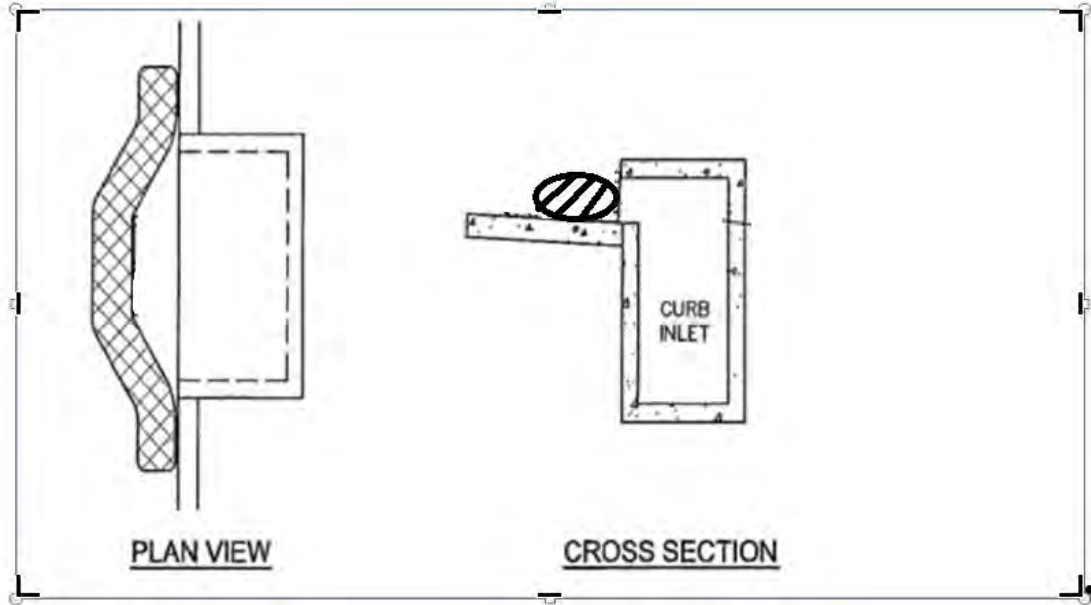
Trench shall be backfilled and compacted to prevent runoff from cutting underneath the fence.

Sediment must be removed when accumulations reach 1/2 the above ground height of the fence.

Any section of Filter fabric fence that has been undermined or topped should be immediately replaced.

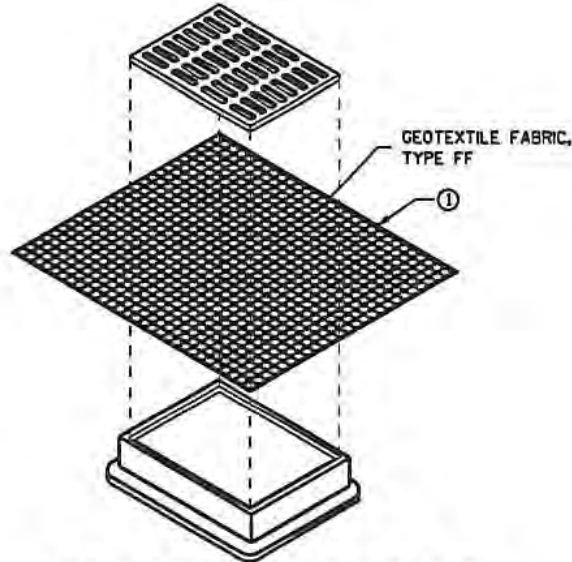
# DETAIL F-7A

## **CURB INLET PROTECTION**



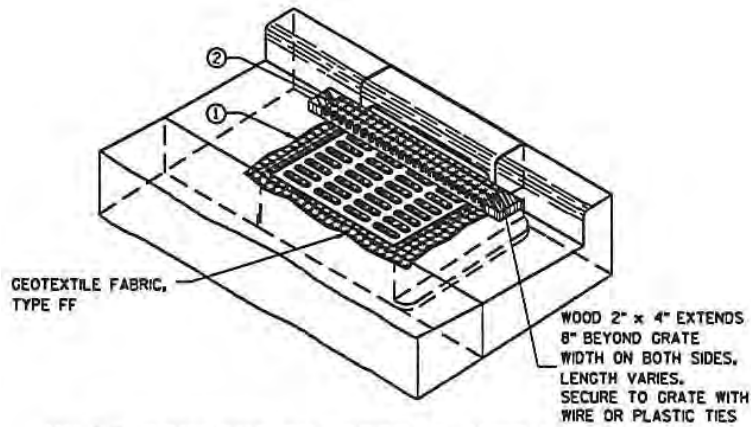
# DETAIL F-7B

## CURB INLET PROTECTION



**INLET PROTECTION, TYPE B  
(WITHOUT CURB BOX)**

(CAN BE INSTALLED IN ANY INLET WITHOUT A CURB BOX)



**INLET PROTECTION, TYPE C (WITH CURB BOX)**

### INSTALLATION NOTES

#### TYPE B & C

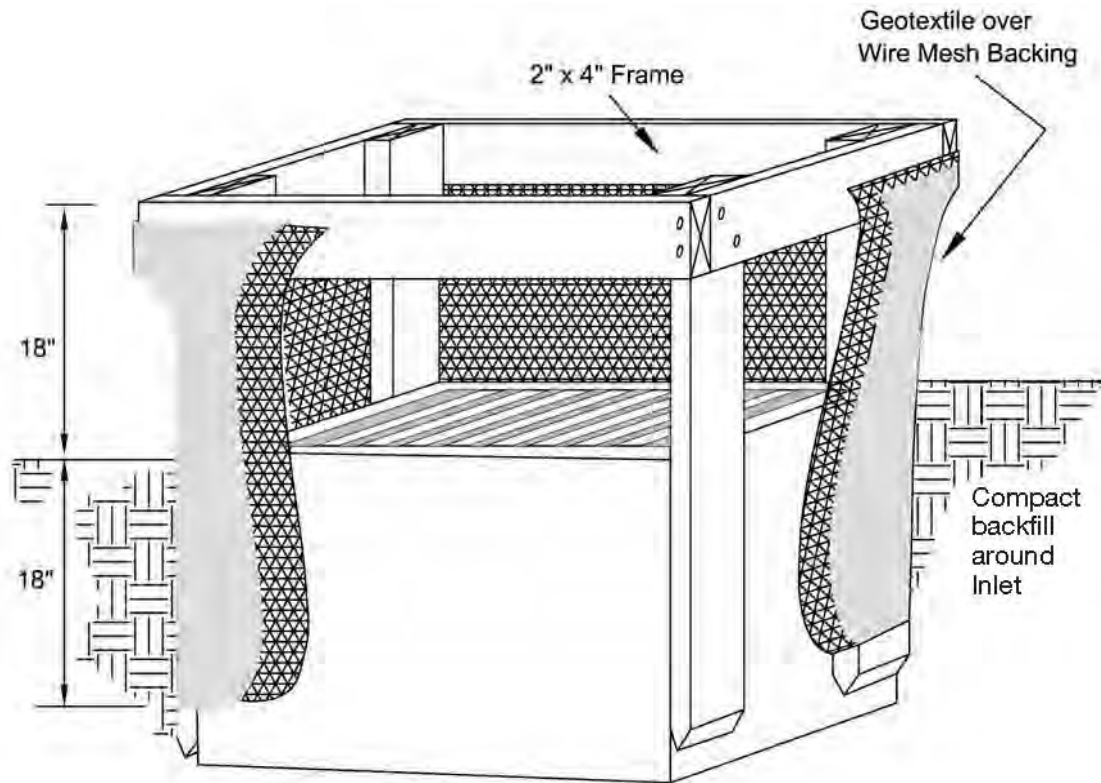
TRIM EXCESS FABRIC IN THE FLOW LINE TO WITHIN 3" OF THE GRATE.

THE CONTRACTOR SHALL DEMONSTRATE A METHOD OF MAINTENANCE, USING A SEWN FLAP, HAND HOLDS OR OTHER METHOD TO PREVENT ACCUMULATED SEDIMENT FROM ENTERING THE INLET.



## DETAIL F-7C

### GEOTEXTILE INLET PROTECTION DETAIL

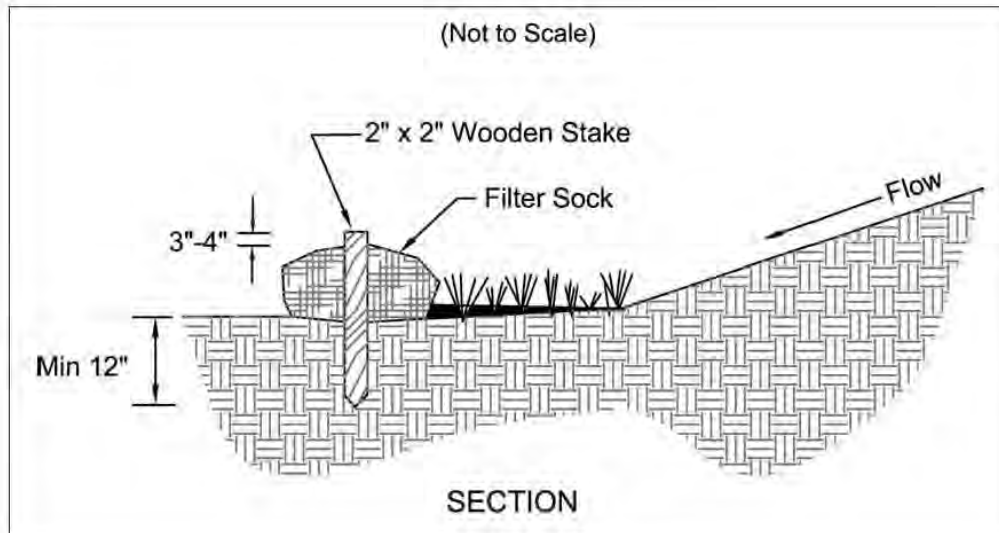


#### SECTION

1. Inlet protection shall be constructed either before upslope land disturbance begins or before the inlet becomes functional.
2. The earth around the inlet shall be excavated completely to a depth at least 18 inches.
3. The wooden frame shall be constructed of 2-inch by 4-inch construction grade lumber. The 2-inch by 4-inch posts shall be driven one (1) ft. into the ground at four corners of the inlet and the top portion of 2-inch by 4-inch frame assembled using the overlap joint shown. The top of the frame shall be at least 6 inches below adjacent roads if ponded water will pose a safety hazard to traffic.
4. Wire mesh shall be of sufficient strength to support fabric with water fully impounded against it. It shall be stretched tightly around the frame and fastened securely to the frame.
5. Geotextile material shall have an equivalent opening size of 20-40 sieve and be resistant to sunlight. It shall be stretched tightly around the frame and fastened securely. It shall extend from the top of the frame to 18 inches below the inlet notch elevation. The geotextile shall overlap across one side of the inlet so the ends of the cloth are not fastened to the same post.
6. Backfill shall be placed around the inlet in compacted 6inch layers until the earth is even with notch elevation on ends and top elevation on sides.
7. A compacted earth dike or check dam shall be constructed in the ditch line below the inlet if the inlet is not in a depression. The top of the dike shall be at least 6 inches higher than the top of the frame.
8. Filter fabric and filter socks can also be used as inlet protection.

# DETAIL F-8

## FILTER SOCK DETAIL



1. Materials – Compost used for filter socks shall be weed, pathogen and insect free and free of any refuse, contaminants or other materials toxic to plant growth. They shall be derived from a well-decomposed source of organic matter and consist of a particles ranging from 3/8" to 2".
2. Filter Socks shall be 3 or 5 mil continuous, tubular, HDPE 3/8" knitted mesh netting material, filled with compost passing the above specifications for compost products.

### INSTALLATION:

3. Filter socks will be placed on a level line across slopes, generally parallel to the base of the slope or other affected area. On slopes approaching 2:1, additional socks shall be provided at the top and as needed mid-slope.
4. Filter socks intended to be left as a permanent filter or part of the natural landscape, shall be seeded at the time of installation for establishment of permanent vegetation.

5. Filter Socks are not to be used in concentrated flow situations or in runoff channels.

### MAINTENANCE:

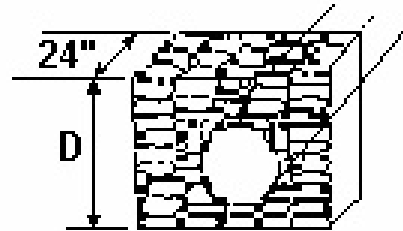
6. Routinely inspect filter socks after each significant rain, maintaining filter socks in a functional condition at all times.
7. Remove sediments collected at the base of the filter socks when they reach 1/3 of the exposed height of the practice.
8. Where the filter sock deteriorates or fails, it will be repaired or replaced with a more effective alternative.
9. Removal – Filter socks will be dispersed on site when no longer required in such a way as to facilitate and not obstruct seedings.

Note: Filter socks may not require stakes if used in areas of little to no slope, for short duration, and/or for relatively small disturbances such as sidecast piles from service line tie-ins.

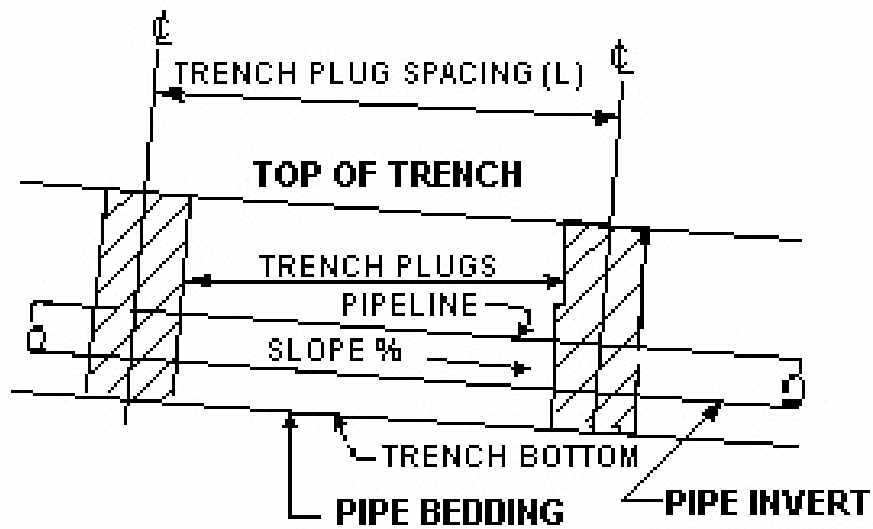
# DETAIL F-9

## TRENCH PLUG INSTALLATION DETAIL

D - DEPTH TO BOTTOM OF TRENCH



**SECTION VIEW**  
NOT TO SCALE



**ELEVATION**  
NOT TO SCALE



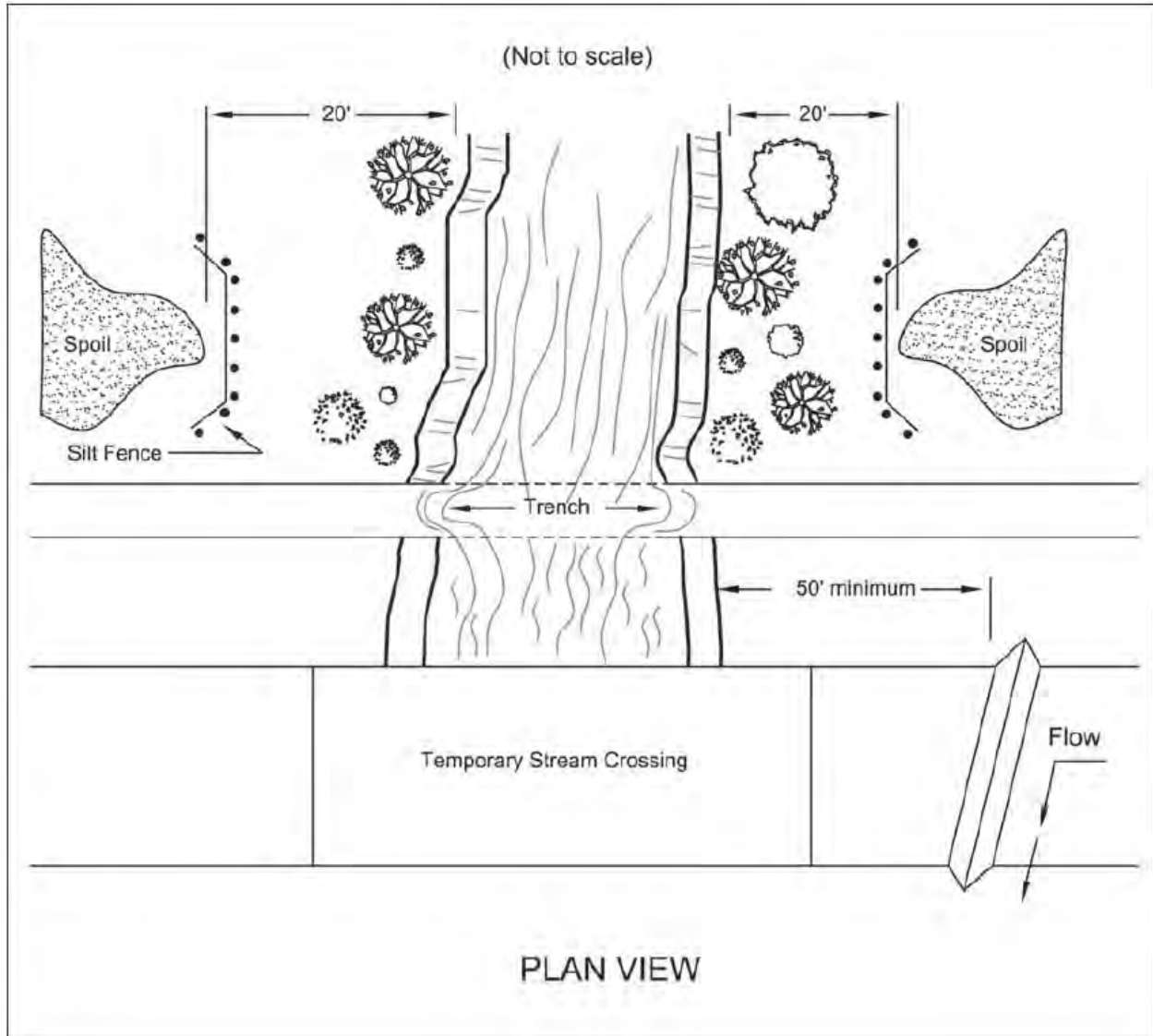
---

## **APPENDIX G**

### **Typical Stream Crossing Drawings**

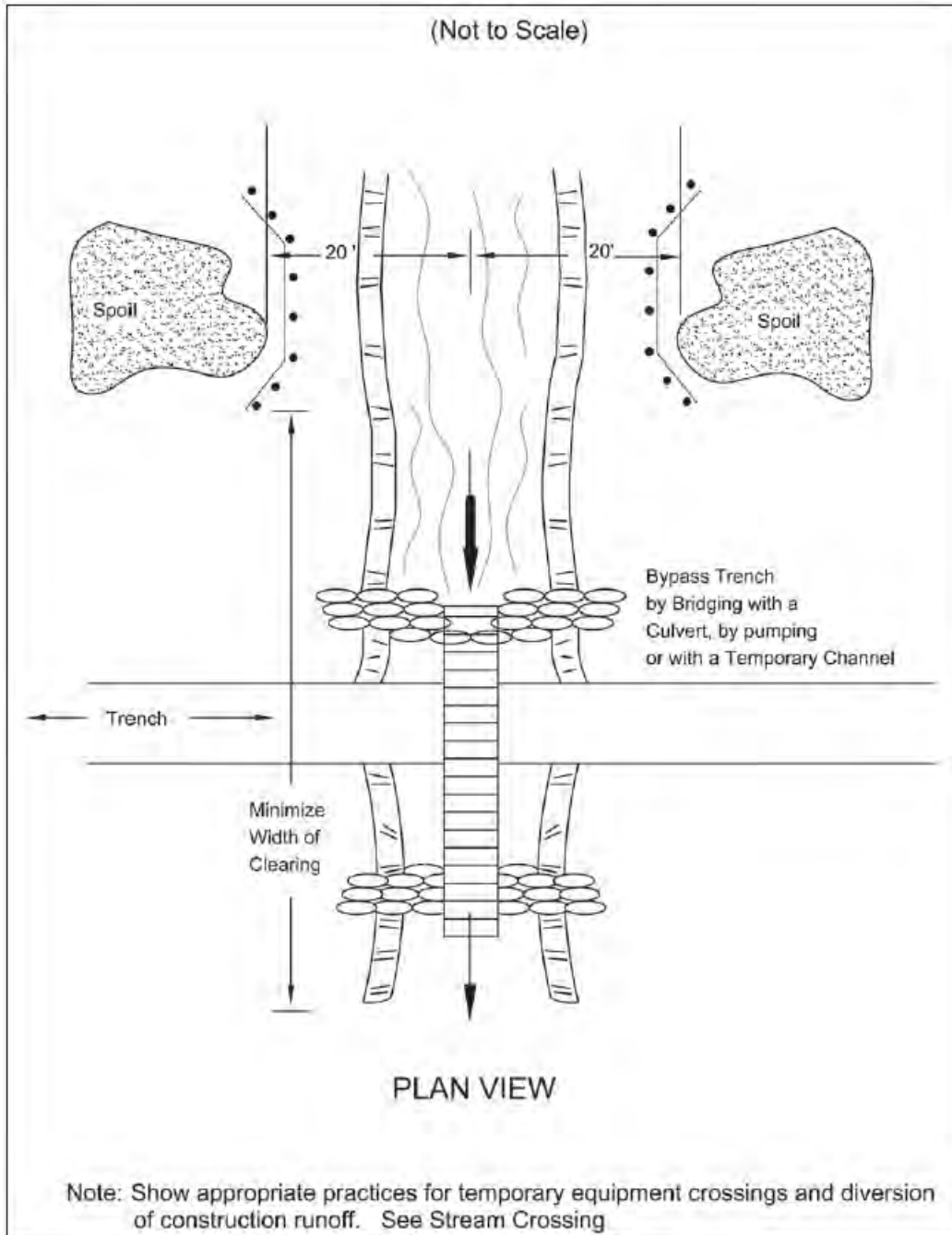
# DETAIL G-1

## LARGE STREAM UTILITY CROSSING



## DETAIL G-2

### SMALL STREAM UTILITY CROSSING



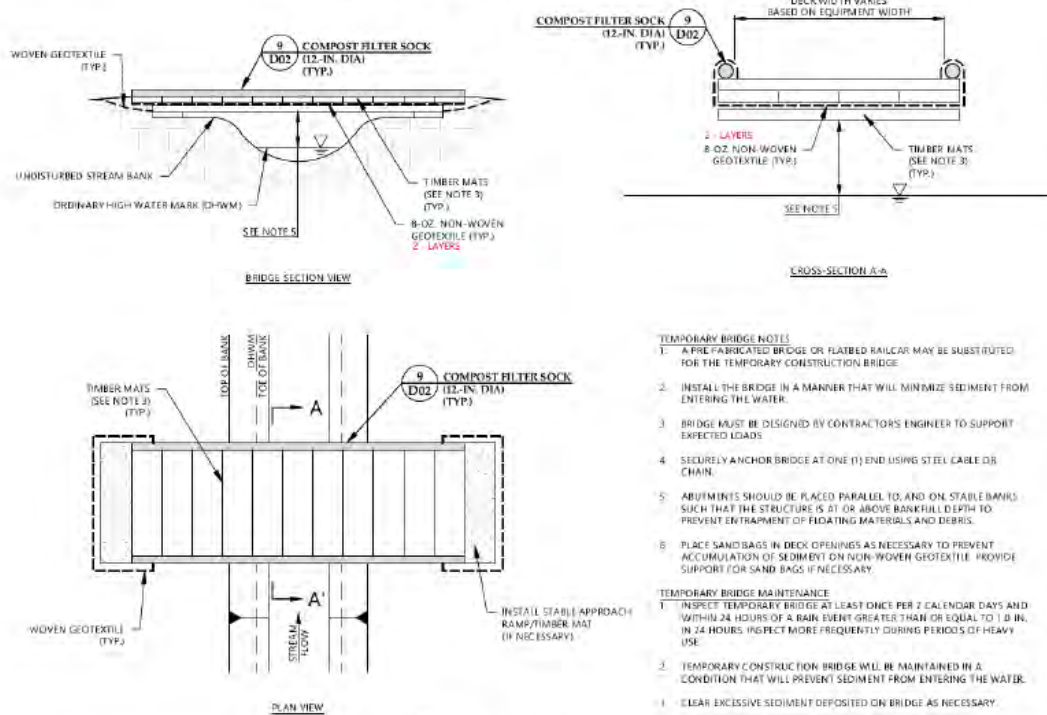
Notes: A diversion barrier may also be used to direct water away from the pipe trench  
Trench plugs will be installed as necessary on each side of water body crossings.



# DETAIL G-3

## TEMPORARY ACCESS BRIDGE

### TEMPORARY ACCESS BRIDGE

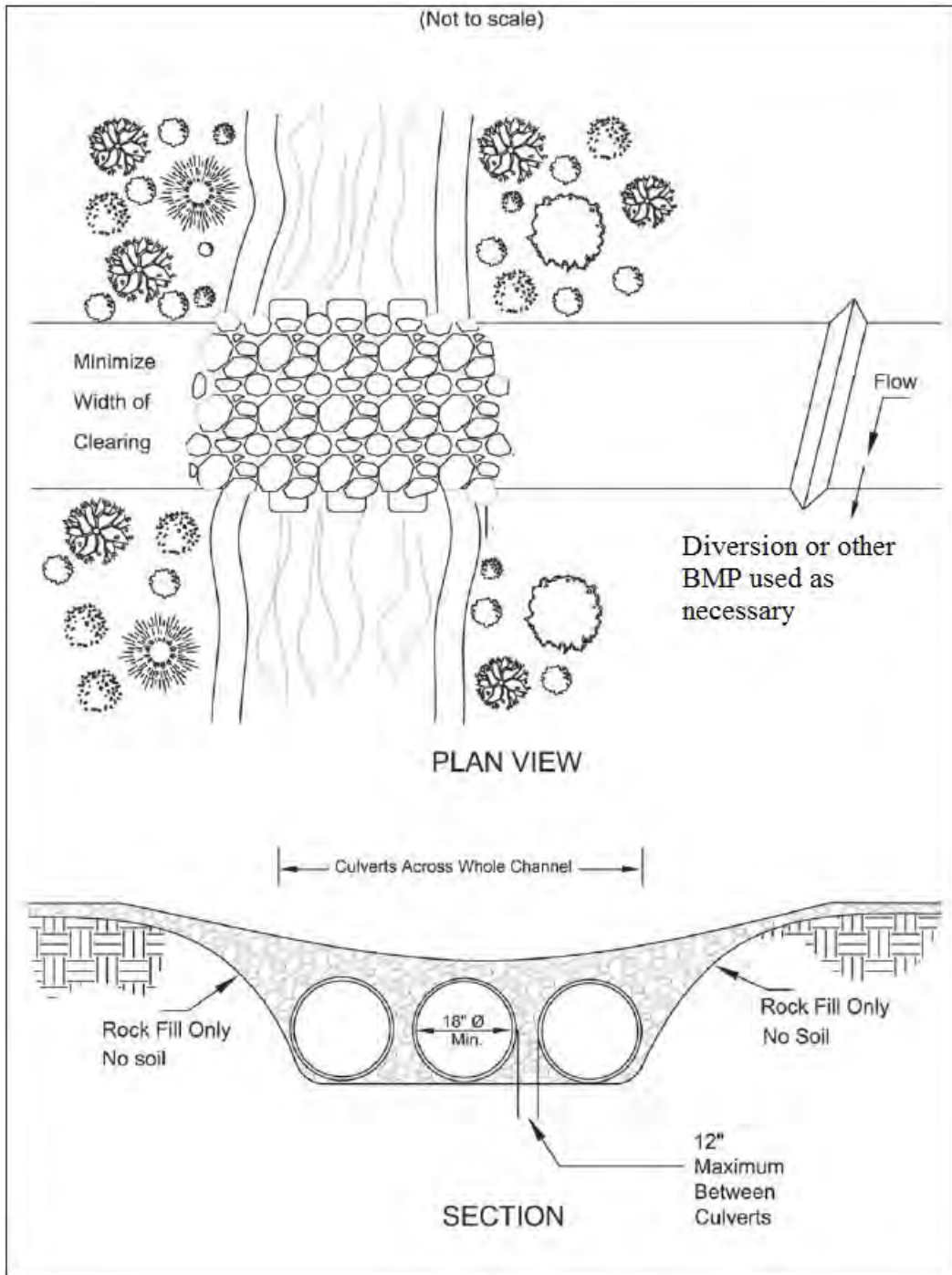


**7**  
**D02** TEMPORARY BRIDGE  
NOT TO SCALE

- Notes:**
1. Culvert Pipes may be utilized instead of footings, piers or other bridge supports.
  2. Bridge will be temporarily removed during high water events.
  3. Bridge to remain until the completion of final restoration.
  4. Filter socks shall surround the bridge structure above the water line; removed during use, and replaced at night.
  5. Ramp approaches can be either graded or dug into the ground. Stone may be used on approaches.
  6. **Winter Conditions:** When necessary, excess ice and snow should be removed from the mats to allow the equipment to have proper traction. Ensure mats are positioned and leveled to decrease the chance equipment could slide on them. Exercise Stop Work Authority if conditions are unsafe.

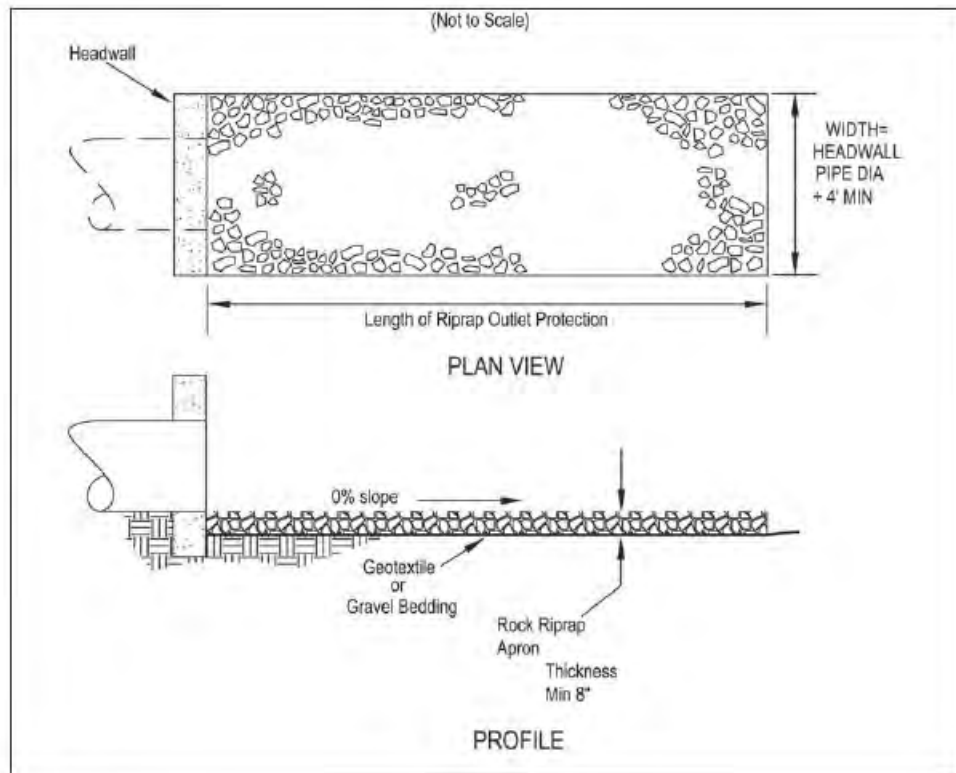
# DETAIL G-4

## CULVERT (FLUMED) STREAM CROSSING



## DETAIL G-5

### ROCK OUTLET PROTECTION



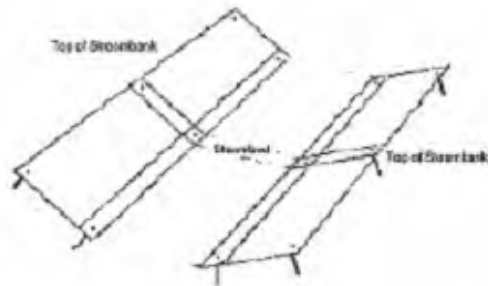
1. Subgrade for the filter or bedding and riprap shall be prepared to the required lines and grades as shown on the plan. The subgrade shall be cleared of all trees, stumps, roots, sod, loose rock, or other material.
2. Riprap shall conform to the grading limits as shown on the plan.
3. Geotextile shall be securely anchored according to manufacturers' recommendations.
4. Geotextile shall be laid with the long dimension parallel to the direction of flow and shall be laid loosely but without wrinkles and creases. Where joints are necessary, strips shall be placed to provide a 12-in. minimum overlap, with the upstream strip overlapping the downstream strip.
5. Gravel bedding shall be ODOT No. 67's or 57's unless shown differently on the drawings.
6. Riprap may be placed by equipment but shall be placed in a manner to prevent slippage or damage to the geotextile.
7. Riprap shall be placed by a method that does not cause segregation of sizes. Extensive pushing with a dozer causes segregation and shall be avoided by delivering riprap near its final location within the channel.
8. Construction shall be sequenced so that outlet protection is placed and functional when the storm drain, culvert, or open channel above it becomes operational.
9. All disturbed areas will be vegetated as soon as practical.



## DETAIL G-6

### **STREAM BANK RESTORATION DETAIL**

#### Erosion Control Mat Details



Refer to matting manufacturer's installation detail for overlap, embedment, staple patterns, and vegetative stabilization specifications

#### Stream Rip-Rap Details



**The following guidelines will be used to select riprap size and thickness:**

- For channels with water depth > 3 feet, use R-5 at 6" thick.
- For channels with water depth between 2 and 3 feet, use R-4 at 4" thick
- For channels with water depth between 1 and 2 feet, use R-3 at 3" thick
- For channels with water depth < 1 feet, use R-2 at 3" thick

Specifications  
for  
**Stream Utility Crossing**

---

1. When site conditions allow, one of the following shall be used to divert stream flow or keep the flow away from construction activity.
  - Drill or bore the utility lines under the stream channel.
  - Construct a cofferdam or barricade of sheet pilings, sandbags or a turbidity curtain to keep flow from moving through the disturbed area. Turbidity curtains shall be a pre-assembled system and used only parallel to flow.
  - Stage construction by confining first one-half of the channel until work there is completed and stabilized, then move to the other side to complete the crossing.
  - Route the stream flow around the work area by bridging the trench with a rigid culvert, pumping, or constructing a temporary channel. Temporary channels shall be stabilized by rock or a geotextile completely lining the channel bottom and side slopes.
2. Crossing Width -The width of clearing shall be minimized through the riparian area. The limits of disturbance shall be as narrow as possible including not only construction operations within the channel itself but also clearing done through the vegetation growing on the streambanks.
3. Clearing shall be done by cutting NOT grubbing. The roots and stumps shall be left in place to help stabilize the banks and accelerate revegetation.
4. Material excavated from the trench shall be placed at least 20 ft. from the streambanks.
5. To the extent other constraints allow, stream shall be crossed during periods of low flow.
6. Duration of Construction -The time between initial disturbance of the stream and final stabilization shall be kept to a minimum. Construction shall not begin on the crossing until the utility line is in place to within 10 ft. of the streambank.
7. Fill Placed Within the Channel -The only fill permitted in the channel should be clean aggregate, stone or rock. No soil or other fine erodible material shall be placed in the channel. This restriction includes all fill for temporary crossings, diversions, and trench backfill when placed in flowing water. If the stream flow is diverted away from construction activity the material originally excavated from the trench may be used to backfill the trench.
8. Streambank Restorations -Streambanks shall be restored to their original line and grade and stabilized with riprap or vegetative bank stabilization.
9. Runoff Control Along the Right-of-Way -To prevent sediment-laden runoff from flowing to the stream, runoff shall be diverted with water bar or swales to a sediment trapping practice a minimum of 50 ft. from the stream.
10. Sediment laden water from pumping or dewatering or pumping shall not be discharged directly to a stream. Flow shall be routed through a settling pond, dewatering sump or a flat, well-vegetated area adequate for removing sediment before the pumped water reaches the stream.
11. Dewatering operations shall not cause significant reductions in stream temperatures. If groundwater is to be discharged in high volumes during summer months, it shall first be routed through a settling pond or overland through a flat well-vegetated area.
12. Permits -In addition to these specifications, stream crossings shall conform to the rules and regulations of the U.S. Army Corps of Engineers for in-stream modifications (404 permits) and Ohio Environmental Protection Agency's State Water Quality Certification (401 permits).

---

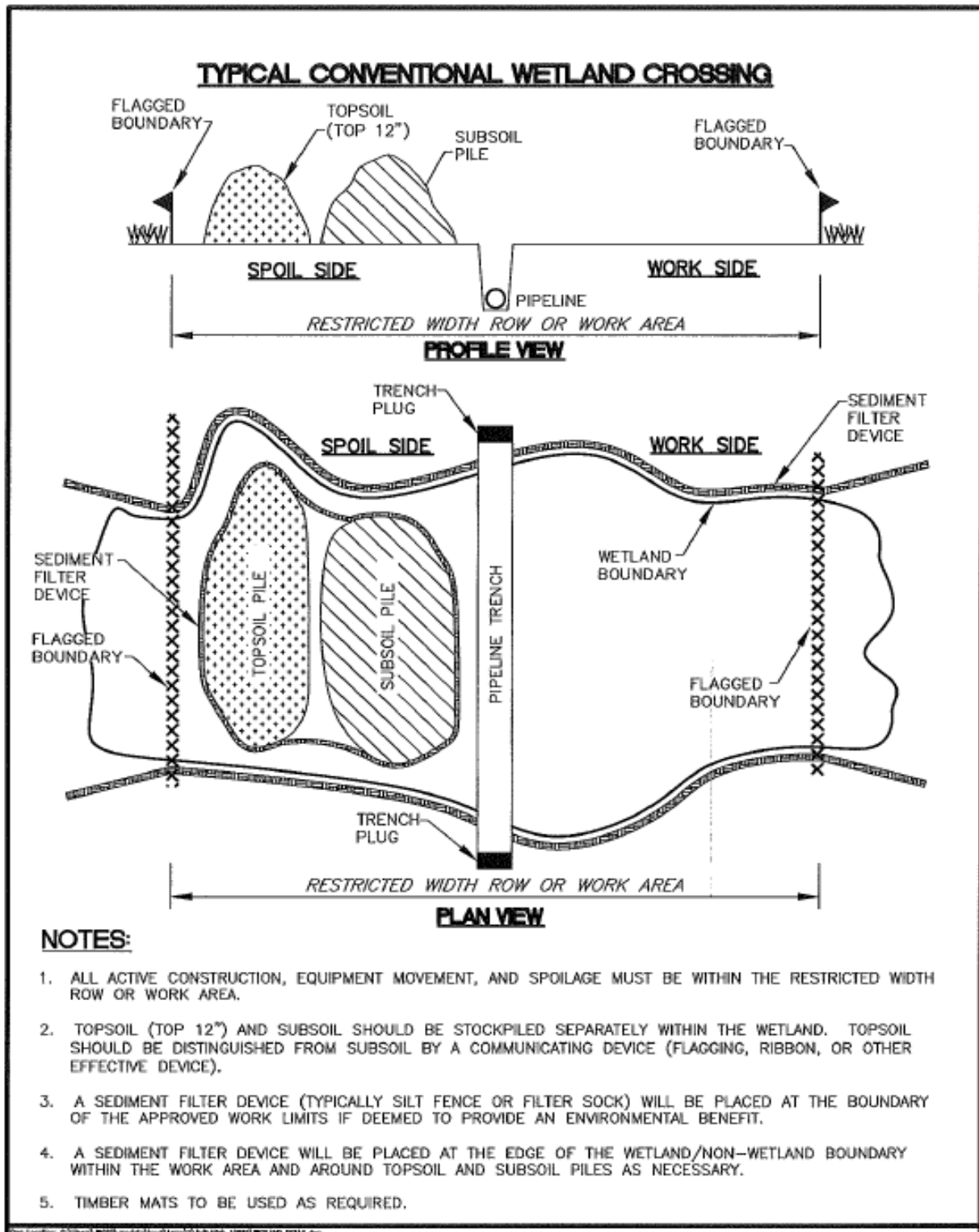
## **APPENDIX H**

# **Typical Wetland Crossing Drawings**



# DETAIL H-1

## TYPICAL WETLAND CROSSING



## DETAIL H-2

### **WETLAND TIMBER MAT CROSSING**



---

**APPENDIX I**

**NOI Application  
Documentation**




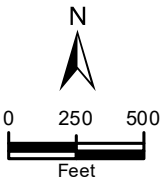


*Please add any additional comments or attachments below.*

Project Name: PIR 2788 – Apple Creek  
Facility Contact: David Hollendonner



 Project Study Area



**Figure 1**  
**Site Location Map**  
PIR 2788 - Apple Creek  
Dominion Energy Ohio  
Wayne County, Ohio  
Date: 1/17/2024

Base Layer: ESRI StreetMap, 2022





---

**APPENDIX J**

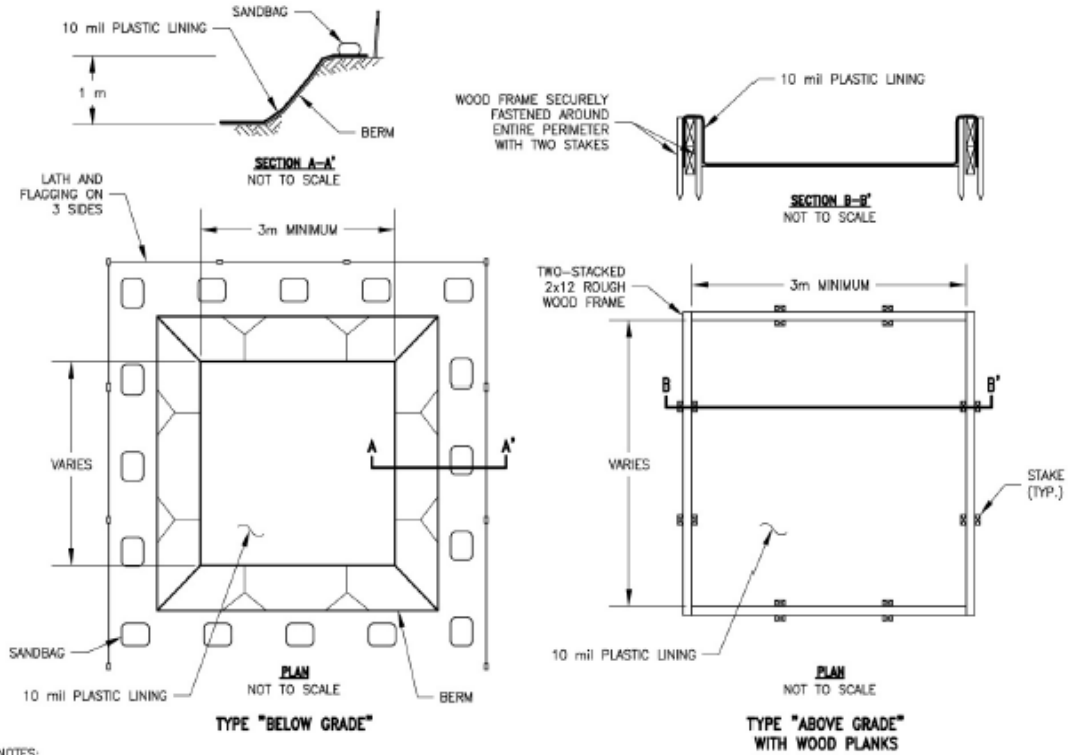
**Concrete Washout Typical  
Detail**

# DETAIL J-1

## Concrete Washout Detail\*

Note: This detail to be used in the absence of the following concrete washout BMPs:

1. Washout into a depressional area where new sidewalks will be poured.
2. Washout into a lined pit in the ground with filter socks as perimeter control.



**NOTES:**

1. ACTUAL LAYOUT DETERMINED IN THE FIELD.
2. THE CONCRETE WASHOUT SIGN (SEE PAGE 8) SHALL BE INSTALLED WITHIN 10 m. OF THE TEMPORARY CONCRETE WASH-OUT FACILITY.



Sign Examples



Photograph of the "ABOVE GRADE" concrete washout structure

- \* 1. Concrete washout location is subject to change and will be located by the contractor before construction begins.
2. Concrete washout will be installed away from wetlands and streams.
3. Proper removal and disposal of concrete washout material is required once the project is complete.

---

**APPENDIX K**

**SWP3 Inspection Forms**



## ECTS Checklist Guidance

---

### Checklist Title: SWP3 Inspection Form

(For Dominion Energy Construction Projects with a SWP3)

THIS CHECKLIST IS TO BE COMPLETED BY AN ENVIRONMENTAL INSPECTOR (EI) CONTRACTED BY DOMINION ENERGY OR A DOMINION ENERGY INSPECTOR DURING SCHEDULED OR UNSCHEDULED SITE INSPECTIONS OF ACTIVE CONSTRUCTION SITES WITH A SWP3.

- **Information at the top of the form.**

- **Site Name:** Note the Project name and/or location of the construction activity.
- **Inspector:** Note the inspector’s name and circle the appropriate title.
- **Qualifications:** Note applicable qualifications.
  - Eight-Hour Stormwater Management During Construction Course - A course administered by numerous third-party trainers.
  - CESSWI - Certified Erosion, Sediment and Stormwater Inspector. A federal certification program administered by EnviroCert International. If “Yes” include certification number.
  - Dominion SWP3 Training - A training module prepared by Dominion Energy Environment and Sustainability for Dominion Energy construction Sites
  - Other – List other applicable qualifications
- **Signature:** Include the signature of the inspector on paper copy maintained at the site.

- **Inspection Documentation Area:**

- **Circle the applicable inspection type:**
  - “Weekly” - Inspection required at least once every seven calendar days during active construction and restoration.
  - “Monthly” - Inspection required after all construction and restoration activity has ceased.
  - “Routine” - Minimum weekly inspection interval
  - “Precipitation Event” - Must be completed at least once every seven (7) calendar days and after any storm event greater than one-half inch of rain per 24-hour period by the end of the next calendar day, excluding weekends and holidays, unless work is scheduled. Rainfall amounts will be determined by Dominion Energy personnel or a designated representative using National Weather Service or other acceptable resources such as an on-site rain gauge.
  - “Other” - Random inspection, Compliance Inspection, Follow-up, etc.
- **Has it rained since last inspection? (Y/N)** Circle as appropriate and note the time started and duration of the previous storm event. If the precipitation amount is known, insert this information here.
- **Current Conditions:** Describe the weather conditions during this inspection. Circle the most appropriate soil condition. “Saturated” = standing water is visible on the ground surface.
- **Features Inspected:** List each feature inspected at the site. The Feature ID must correspond to the site plan submitted with the SWP3 or E&S Control Plan. Record any repairs or maintenance necessary for each device; include an accurate description of the

location of repair and a date when the repair must be completed.

- **Information on second page.**

- **Construction Inspector(s):** Note the inspection date, site name, and inspector's name.
- **Previous Inspections:** Review the previous site inspection form, including action items and dates of completion. Comment on any ongoing activities and its progress. The site has three days from discovery to complete applicable repairs and 10 days from discovery to install new controls if warranted.
- **Necessary Documents:** Confirm the presence of environmental permit, plans, and notices. These must include: a Stormwater Pollution Prevention Plan (SWP3) or Erosion and Sediment (E&S) Control Plan; Construction Permit/Land Disturbance Permit; Notice of Intent (NOI) to begin disturbance; and Notices of Termination.
- **Disturbed Areas:** Any disturbed areas that are anticipated to lie dormant for more than 14 days must be stabilized to prevent potential erosion. Stabilization may include: permanent cover (e.g., building, parking lot, etc.); vegetation (seed and straw), mulch or tack; gravel, stone or rip rap.
- **E/SCDs:** Are Erosion/Sediment Control Devices (E/SCDs) of appropriate design for the areas they are controlling, properly installed and being maintained? The E/SCDs installed must be described in the SWP3 or E&S Control Plan. Furthermore, design details must meet the minimum design details described in the state stormwater control manual. If alternate control methods were installed: notify the site manager and engineer to confirm the controls installed are sufficiently designed; revise the plans accordingly; or remove and replace insufficient controls. The site has three days from discovery to complete applicable repairs and 10 days from discovery to install new controls if warranted.
- **Final Grade:** List any areas at final grade since last inspection. Areas at final grade are not likely to be disturbed again and must be stabilized. See Question # 9 above.
- **Untreated Discharges:** Observations of untreated discharge may include:
  - A sheen indicating petroleum products;
  - Foam or froth indicating a chemical or other discharge;
  - Suspended particles or sludge beneath the surface;
  - Discolored water, including dirty/muddy characteristics of sedimentation;
  - A change in water temperature; and
  - Damaged or stressed vegetation or wildlife.
- **Notification:** Review the inspection findings with a site manager or other responsible person and note this individual.

Checklist Owner: Tara Buzzelli

Local: 8-657-2579

Work: 330-664-2579

Cell: 330-604-8871

Email: Tara.E.Buzzelli@DominionEnergy.com

Email: Gregory.K.Eastridge@DominionEnergy.com

Date of Last Revision: July 2020

Subject Matter Expert: Greg Eastridge

Local: 8-657-2576

Work: 330-664-2576

Cell: 330-571-7855

## OHIO SWP3 INSPECTION FORM

Site Name: \_\_\_\_\_

Date: \_\_\_\_\_

Environmental Inspection Company: \_\_\_\_\_

Environmental Inspector: \_\_\_\_\_

Qualifications: Completed 8-HR Stormwater Management During Construction Course	Y	N
CESSWI	Y	N
Dominion SWP3 Training	Y	N
Other: _____		

Inspector Signature: \_\_\_\_\_

**Weekly**

**Monthly**

**Routine Inspection**

**Precipitation Event >0.5-inch**

**Other** \_\_\_\_\_

*(circle all applicable)*

**Has it rained since last inspection?** *(circle one)*

**Yes: Date(s) & Approx. Amount** \_\_\_\_\_

**No**

**Current Conditions:** \_\_\_\_\_

**Soil Conditions:**

**Dry**

**Wet**

**Saturated**

**Frozen**

*(circle applicable conditions)*

**Feature ID**

**BMP, ECD, SCD Applied**

**Recommendations**

Feature ID	BMP, ECD, SCD Applied	Recommendations

BMP: Best Management Practice E/SCD: Erosion/Sediment Control Device SF: Silt Fence SW: Straw Wattle W: Wetland S: Stream  
 TM: Timber Mat IP: Inlet Protection WB: Waterbar RCE: Rock Construction Entrance ECM: Erosion Control Matting FS: Filter Sock



Date:

Site:

---

**Stormwater Pollution Prevention Plan Inspection Form**

---

**Construction Inspector(s) On Site:**

---

**Unresolved issues from previous inspections:**

---

**Are the SWP3, NOI and General Permit Letter on-site?      Yes      No**  
**If no, explain.**

---

**List newly disturbed areas likely to lie dormant for more than 14 days:**

---

**Have soil stockpiles been placed at least 50 feet from drainageways?**

---

**List construction entrances and SCDs used to prevent tracking into roadway:**

---

**Are E/SCDs of appropriate design for area they are controlling, properly installed and being maintained?**

---

**List any new areas at final grade since last inspection:**

---

**Is the inlet protection of appropriate design?**

---

**Were any untreated discharges into streams, wetlands or inlets observed? If yes, document location(s):**

---

**Note person(s) notified of any inspection finding(s) and expected date of correction:**

---

**Notes**

---

**APPENDIX L**

**Seeding Specifications**

# APPENDIX L-1

Specifications  
for

## Temporary Seeding

Table 7.8.1 Temporary Seeding Species Selection

Seeding Dates	Species	Lb./1000 ft2	Lb/Acre
March 1 to August 15	Oats	3	128 (4 Bushel)
	Tall Fescue	1	40
	Annual Ryegrass	1	40
	Perennial Ryegrass	1	40
	Tall Fescue	1	40
	Annual Ryegrass	1	40
	Annual Ryegrass	1.25	55
	Perennial Ryegrass	3.25	142
	Creeping Red Fescue	0.4	17
	Kentucky Bluegrass	0.4	17
August 16th to November	Oats	3	128 (3 bushel)
	Tall Fescue	1	40
	Annual Ryegrass	1	40
August 16th to November	Rye	3	112 (2 bushel)
	Tall Fescue	1	40
	Annual Ryegrass	1	40
	Wheat	3	120 (2 bushel)
	Tall Fescue	1	40
	Annual Ryegrass	1	40
	Perennial Rye	1	40
	Tall Fescue	1	40
	Annual Ryegrass	1	40
	Annual Ryegrass	1.25	40
Perennial Ryegrass	3.25	40	
Creeping Red Fescue	0.4	40	
Kentucky Bluegrass	0.4	40	
November 1 to Feb. 29	Use mulch only or dormant seeding		

Note: Other approved species may be substituted.

1. Structural erosion and sediment control practices such as diversions and sediment traps shall be installed and stabilized with temporary seeding prior to grading the rest of the construction site.
2. Temporary seed shall be applied between construction operations on soil that will not be graded or reworked for 21 days or greater. These idle areas shall be seeded within 7 days after grading.
3. The seedbed should be pulverized and loose to ensure the success of establishing vegetation. Temporary seeding should not be postponed if ideal seedbed preparation is not possible.
4. Soil Amendments—Temporary vegetation seeding rates shall establish adequate stands of vegetation, which may require the use of soil amendments. Base rates for lime and fertilizer shall be used.
5. Seeding Method—Seed shall be applied uniformly with a cyclone spreader, drill, cultipacker seeder, or hydroseeder. When feasible, seed that has been broadcast shall be covered by raking or dragging and then lightly tamped into place using a roller or cultipacker. If hydroseeding is used, the seed and fertilizer will be mixed on-site and the seeding shall be done immediately and without interruption.



Specifications  
for  
**Temporary Seeding**

---

### Mulching Temporary Seeding

1. Applications of temporary seeding shall include mulch, which shall be applied during or immediately after seeding. Seedings made during optimum seeding dates on favorable, very flat soil conditions may not need mulch to achieve adequate stabilization.
2. Materials:
  - Straw—If straw is used, it shall be unrotted small-grain straw applied at a rate of 2 tons per acre or 90 lbs./ 1,000 sq. ft. (2-3 bales)
  - Hydroseeders—If wood cellulose fiber is used, it shall be used at 2000 lbs./ ac. or 46 lb./ 1,000-sq.-ft.
  - Other—Other acceptable mulches include mulch mattings applied according to manufacturer's recommendations or wood chips applied at 6 ton/ ac.
3. Straw Mulch shall be anchored immediately to minimize loss by wind or water. Anchoring methods:
  - Mechanical—A disk, crimper, or similar type tool shall be set straight to punch or anchor the mulch material into the soil. Straw mechanically anchored shall not be finely chopped but left to a length of approximately 6 inches.
  - Mulch Netting—Netting shall be used according to the manufacturers recommendations. Netting may be necessary to hold mulch in place in areas of concentrated runoff and on critical slopes.
  - Synthetic Binders—Synthetic binders such as Acrylic DLR (Agri-Tac), DCA-70, Petroset, Terra Track or equivalent may be used at rates recommended by the manufacturer.
  - Wood-Cellulose Fiber—Wood-cellulose fiber binder shall be applied at a net dry wt. of 750 lb./ac. The wood-cellulose fiber shall be mixed with water and the mixture shall contain a maximum of 50 lb. / 100 gal.

# APPENDIX L-2

Specifications  
for

## Permanent Seeding

---

### Site Preparation

1. Subsoiler, plow, or other implement shall be used to reduce soil compaction and allow maximum infiltration. (Maximizing infiltration will help control both runoff rate and water quality.) Subsoiling should be done when the soil moisture is low enough to allow the soil to crack or fracture. Subsoiling shall not be done on slip-prone areas where soil preparation should be limited to what is necessary for establishing vegetation.
2. The site shall be graded as needed to permit the use of conventional equipment for seedbed preparation and seeding.
3. Topsoil shall be applied where needed to establish vegetation.

### Seedbed Preparation

1. Lime—Agricultural ground limestone shall be applied to acid soil as recommended by a soil test. In lieu of a soil test, lime shall be applied at the rate of 100 pounds per 1,000-sq. ft. or 2 tons per acre.
2. Fertilizer—Fertilizer shall be applied as recommended by a soil test. In place of a soil test, fertilizer shall be applied at a rate of 25 pounds per 1,000-sq. ft. or 1000 pounds per acre of a 10-10-10 or 12-12-12 analyses.
3. The lime and fertilizer shall be worked into the soil with a disk harrow, spring-tooth harrow, or other suitable field implement to a depth of 3 inches. On sloping land, the soil shall be worked on the contour.

### Seeding Dates and Soil Conditions

Seeding should be done March 1 to May 31 or August 1 to September 30. If seeding occurs outside of the above-specified dates, additional mulch and irrigation may be required to ensure a minimum of 80% germination. Tillage for seedbed preparation should be done when the soil is dry enough to crumble and not form ribbons when compressed by hand. For winter seeding, see the following section on dormant seeding.

### Dormant Seedings

1. Seedings should not be made from October 1 through November 20. During this period, the seeds are likely to germinate but probably will not be able to survive the winter.
2. The following methods may be used for "Dormant Seeding":

- From October 1 through November 20, prepare the seedbed, add the required amounts of lime and fertilizer, then mulch and anchor. After November 20, and before March 15, broadcast the selected seed mixture. Increase the seeding rates by 50% for this type of seeding.
- From November 20 through March 15, when soil conditions permit, prepare the seedbed, lime and fertilize, apply the selected seed mixture, mulch and anchor. Increase the seeding rates by 50% for this type of seeding.
- Apply seed uniformly with a cyclone seeder, drill, cultipacker seeder, or hydro-seeder (slurry may include seed and fertilizer) on a firm, moist seedbed.
- Where feasible, except when a cultipacker type seeder is used, the seedbed should be firmed following seeding operations with a cultipacker, roller, or light drag. On sloping land, seeding operations should be on the contour where feasible.

### Mulching

1. Mulch material shall be applied immediately after seeding. Dormant seeding shall be mulched. 100% of the ground surface shall be covered with an approved material.
2. Materials
  - Straw—If straw is used it shall be unrotted small-grain straw applied at the rate of 2 tons per acre or 90 pounds (two to three bales) per 1,000-sq. ft. The mulch shall be spread uniformly by hand or mechanically applied so the soil surface is covered. For uniform distribution of hand-spread mulch, divide area into approximately 1,000-sq.-ft. sections and spread two 45-lb. bales of straw in each section.
  - Hydroseeders—If wood cellulose fiber is used, it shall be applied at 2,000 lb./ac. or 46 lb./1,000 sq. ft.
  - Other—Other acceptable mulches include rolled erosion control mattings or blankets applied according to manufacturer's recommendations or wood chips applied at 6 tons per acre.

### 3. Straw and Mulch Anchoring Methods

Straw mulch shall be anchored immediately to minimize loss by wind or water.

- **Mechanical**—A disk, crimper, or similar type tool shall be set straight to punch or anchor the mulch material into the soil. Straw mechanically anchored shall not be finely chopped but, generally, be left longer than 6 inches.
- **Mulch Netting**—Netting shall be used according to the manufacturer's recommendations. Netting may be necessary to hold mulch in place in areas of concentrated runoff and on critical slopes.
- **Asphalt Emulsion**—Asphalt shall be applied as recommended by the manufacture or at the rate of 160 gallons per acre.

- **Synthetic Binders**—Synthetic binders such as Acrylic DLR (Agri-Tac), DCA-70, Petroset, Terra Tack or equivalent may be used at rates specified by the manufacturer.
- **Wood Cellulose Fiber**—Wood cellulose fiber shall be applied at a net dry weight of 750 pounds per acre. The wood cellulose fiber shall be mixed with water with the mixture containing a maximum of 50 pounds cellulose per 100 gallons of water.

#### Irrigation

Permanent seeding shall include irrigation to establish vegetation during dry weather or on adverse site conditions, which require adequate moisture for seed germination and plant growth.

Irrigation rates shall be monitored to prevent erosion and damage to seeded areas from excessive runoff.

Table 7.10.2 Permanent Seeding

Seed Mix	Seeding Rate		Notes:
	Lbs./acre	Lbs./1,000 Sq. Feet	
General Use			
Creeping Red Fescue	20-40	1/2-1	For close mowing & for waterways with <2.0 ft/sec velocity
Domestic Ryegrass	10-20	1/4-1/2	
Kentucky Bluegrass	20-40	1/2-1	
Tall Fescue	40-50	1-1 1/4	
Turf-type (dwarf) Fescue	90	2 1/4	
Steep Banks or Cut Slopes			
Tall Fescue	40-50	1-1 1/4	
Crown Vetch	10-20	1/4-1/2	Do not seed later than August
Tall Fescue	20-30	1/2-3/4	
Flat Pea	20-25	1/2-3/4	Do not seed later than August
Tall Fescue	20-30	1/2-3/4	
Road Ditches and Swales			
Tall Fescue	40-50	1-1 1/4	
Turf-type (Dwarf) Fescue	90	2 1/4	
Kentucky Bluegrass	5	0.1	
Lawns			
Kentucky Bluegrass	100-120	2	
Perennial Ryegrass		2	
Kentucky Bluegrass	100-120	2	For shaded areas
Creeping Red Fescue		1-1/2	

Note: Other approved seed species may be substituted.



---

## **APPENDIX M**

### **Pre-Construction and Post- Construction Runoff Volumes & Peak Rate Calculations**

**Final Volume Calculations**

*(SCS Curve Number Method)*

<b>Parameter</b>	<b>Drainage Area</b>	<b>Proposed Change Area</b>	<b>Notes</b>
Curve Number, CN	83.1	89	<i>Refer "CurveNumber" worksheet for CN values for "Drainage Area"</i>
Precipitation, P (in)	4.42	4.42	<i>25-year 24hr precipitation (Refer "CriticalStorm" worksheet)</i>
Drainage Area (ac)	21472.3	0.220	
Potential maximum retention after runoff begins, S (in)	2.03	1.24	
Runoff (in)	2.66	3.22	
Runoff (ft3)	<b><u>2.08E+08</u></b>	<b><u>2570.9</u></b>	

**Final Peak Runoff Calculations**

*(Rational Method)*

<b>Parameter</b>	<b>Drainage Area</b>	<b>Proposed Change Area</b>	
Runoff Coefficient, C	NA	0.7	<i>Estimated Based on Landuse as per Ohio's Rainwater and Land Development Standards document</i>
Time of concentration, Tc (hours)	NA	0.4	<i>Estimated using TR55</i>
Rainfall Intensity, i (in/hr)	NA	1.16	<i>Estimated based on Tc as per Ohio's Rainwater and Land Development Standards</i>
Peak Flow Rate, Qp (cfs)	<b><u>4380.0</u></b>	<b><u>0.179</u></b>	

***PRE-DEVELOPMENT***

**Parameter**

Curve Number, CN	76
Precipitation, P (in)	2.06 1-year 24hr precipitation
Drainage Area (ac)	0.220
Potential maximum retention after runoff begins, S (in)	3.16
Runoff (in)	0.44
Runoff (ft3)	355.3

**Proposed Change Area**

***POST-DEVELOPMENT***

**Parameter**

Curve Number, CN	89
Precipitation, P (in)	2.06 1-year 24hr precipitation
Drainage Area (ac)	0.220
Potential maximum retention after runoff begins, S (in)	1.24
Runoff (in)	1.08
Runoff (ft3)	860.8
	142%

**Proposed Change Area**

**Critical Storm**

**25-Year**

Based on Ohio's "Rainwater and Land Development Standards" document if post-development 1-Year runoff volume is more than by 100% to 250% of pre-development 1-year runoff volume, 25-year storm is the critical storm to be considered to fulfill water quality standards.



*Areas (acres) of each combination of soil hydrologic group and land use*

LanduseCode	---	A	B	B/D	C	C/D	D	Grand Total	Landuse Name
11	3.06		0.33	0.84	1.68	5.72	5.05	16.68	Openwater
21	0.81	3.43	52.25	21.04	328.04	550.21	74.00	1029.78	Developed Open
22	2.41	2.91	49.78	18.03	390.17	621.42	92.70	1177.42	Developed Low
23	1.32	1.43	19.95	5.88	166.42	305.85	32.76	533.62	Developed Medium
24	8.25	0.22	5.25	0.50	50.98	132.24	13.45	210.89	Developed High
31	0.38		0.28		2.50	11.62	3.76	18.54	Barren
41	0.47	45.39	445.04	257.79	769.65	969.06	238.15	2725.56	Forest
42			20.26		38.27	22.49	1.93	82.95	Forest
43	0.25	2.18	35.72	18.08	130.81	116.03	22.07	325.15	Forest
52		0.67	0.05	0.11	3.81	5.80	10.69	21.13	Shrub
71		1.11	2.10	0.33	11.07	16.99	4.28	35.88	Grass
81	14.58	9.98	317.73	311.60	2079.85	3289.72	485.22	6508.68	Pasture
82	15.80	18.55	178.75	308.64	1844.30	5223.13	1045.66	8634.84	Crop
90		5.52	0.08	11.56	16.91	57.88	2.10	94.06	Wetland
95				0.63	0.26			0.89	Wetland

**21416.04**

*Curve Number for each combination of soil hydrologic group and land use*

LanduseCode							
11	100.00	100.00	100.00	100.00	100.00	100.00	100.00
21	84.00	49.00	69.00	84.00	79.00	84.00	84.00
22	82.00	46.00	65.00	82.00	77.00	82.00	82.00
23	86.00	57.00	72.00	86.00	81.00	86.00	86.00
24	92.00	77.00	85.00	92.00	90.00	92.00	92.00
31	94.00	77.00	86.00	94.00	91.00	94.00	94.00
41	79.00	36.00	60.00	79.00	73.00	79.00	79.00
42	79.00	36.00	60.00	79.00	73.00	79.00	79.00
43	79.00	36.00	60.00	79.00	73.00	79.00	79.00
52	79.00	36.00	60.00	79.00	73.00	79.00	79.00
71	84.00	49.00	69.00	84.00	79.00	84.00	84.00
81	84.00	49.00	69.00	84.00	79.00	84.00	84.00
82	89.00	67.00	78.00	89.00	85.00	89.00	89.00
90	100.00	100.00	100.00	100.00	100.00	100.00	100.00
95	100.00	100.00	100.00	100.00	100.00	100.00	100.00

*Curve Number contribution of each combination of soil hydrologic group and land use*

LanduseCode							
11	0.01	0.00	0.00	0.00	0.01	0.03	0.02
21	0.00	0.01	0.17	0.08	1.21	2.16	0.29
22	0.01	0.01	0.15	0.07	1.40	2.38	0.35
23	0.01	0.00	0.07	0.02	0.63	1.23	0.13
24	0.04	0.00	0.02	0.00	0.21	0.57	0.06
31	0.00	0.00	0.00	0.00	0.01	0.05	0.02
41	0.00	0.08	1.25	0.95	2.62	3.57	0.88
42	0.00	0.00	0.06	0.00	0.13	0.08	0.01
43	0.00	0.00	0.10	0.07	0.45	0.43	0.08
52	0.00	0.00	0.00	0.00	0.01	0.02	0.04
71	0.00	0.00	0.01	0.00	0.04	0.07	0.02
81	0.06	0.02	1.02	1.22	7.67	12.90	1.90
82	0.07	0.06	0.65	1.28	7.32	21.71	4.35
90	0.00	0.03	0.00	0.05	0.08	0.27	0.01
95	0.00	0.00	0.00	0.00	0.00	0.00	0.00

**83.1** Total weighted curve number for the drainage area

**Attachment 2**  
**CAP Permit Application**

WAYNE COUNTY, OHIO  
CONSTRUCTION APPLICATION FOR PERMIT (CAP)

428 West Liberty Street, Wooster, Ohio 44691  
330-263-5376

Storm Water Construction (SWC) Permit Number \_\_\_\_\_

Construction Application for Permit (CAP) Number \_\_\_\_\_

Date Received: \_\_\_\_\_

**Property Owner Information**

Name: The East Ohio Gas Company, d/b/a Dominion Energy Ohio

Address, City, State & Zip Code 320 Springside Drive, Suite 320, Akron, Ohio 44333

Phone: (330) 664-2576 E-mail: gregory.k.eastridge@dominionenergy.com

**Contact Person or Contractor Information**

Name: Gregory Eastridge (on behalf of Zachary Goodson)

Address, City, State & Zip Code 320 Springside Drive, Suite 320

Phone: (330) 664-2576 E-mail: gregory.k.eastridge@dominionenergy.com

**Site Information**

Project Name: PIR 2788 - Apple Creek

Project Address: N Hillcrest Drive and S Geyers Chapel Road ( 40.802776°, -81.900373°)

Township: Wooster (T15N, R13W) Section 02 Quarter Section: \_\_\_\_\_

In 3-Mile Limit (Yes/City or No)? Yes/within 3-miles of City of Wooster

Description of Earth Disturbing Activity/ Proposed Land Use/Purpose of CAP: Approx. 3,900 ft of gas utility pipeline will be installed; as will a permanent gravel access to an underground drip tank with above ground 2" siphon riser & 4 bollards.

Total Area of Lot or Common Development (sf or Acres): 12.7

Total Area to be Disturbed (sf or Acres): 5.4 acres

Total New Impervious Area (sf or Acres): 0.20 acres

Is the proposed work adding any new bedrooms:  Yes/No  If yes, how many? \_\_\_\_\_

Will the new structure/dwelling have new plumbing  Yes/No

Will you be connecting to central sanitary sewer  Yes/No  If yes, what municipality's sanitary sewer will serve the property? \_\_\_\_\_

Construction Start Date: June 1, 2024 Construction End Date: December 31, 2024

**Project Type**

- Residential
- Non-Residential (e.g. Commercial, Industrial, etc.)

**CAP and Floodplain Review Fee**

CAP Fee \$ 600

Floodplain Review Permit Fee \$200

Total Fee \_\_\_\_\_ Receipt # \_\_\_\_\_

Initial Block: Planning Dept. \_\_\_\_\_ Health Dept. \_\_\_\_\_ County Engineer's Office \_\_\_\_\_



**CAP Attachments (Check if Applicable and Attached to CAP)**

Storm Water Pollution Prevention Plan (SWP3)

**Permits from or Plans Required by Wayne County Entities:**

Floodplain Review and/or Development Permit (Planning Department) Permit # \_\_\_\_\_

Proof of Submission for Zoning Permit (Chippewa Township)

Sanitary Sewer Permit (Environmental Services) Date Reviewed \_\_\_\_\_

Central Sanitary Sewer

Community (City or Village) Date Reviewed \_\_\_\_\_

Wayne County Date Reviewed \_\_\_\_\_

Proof of Submission for Approval of Work in County Road R-O-W or Road Use (e.g. drive pipe, yard pipe, utility installation, special hauling, etc.)

• Contact the applicable township(s) for permits required for work in the road R-O-W

Application for Onsite Sewage Treatment System (Septic) Permit (Health Department) and/or Private Water System Permit/Alteration Permit

\*It is the responsibility of the owner/contractor to contact agencies outside of Wayne County

**County Engineer's Office Plans**

Drainage Plan and Erosion & Sedimentation Control Plan (Major Subdivision)

**Waiver Requested** (Disturbed area < 1 acre and new impervious area < 20,000 square feet)

**SEDIMENT AND EROSION CONTROL MEASURE(S) MUST BE TAKEN.** \*\* Check the type of control measure(s) that you will use. See Fact Sheet for further descriptions.

**Seed and Mulch Disturbed Soils.** Must be done within 7 days after last disturbance, or within 2 days after last disturbance if within 50 ft. of a stream. This is used for temporary and permanent soil stabilization.

**Silt Fence.** Installed within 7 days of clearing and grubbing, before earth disturbing activity. Protects from muddy runoff. Fence must be placed in a trench having 6"-8" of the fence buried and kept tight. Place silt fence on level ground back from slope.

**Construction Site Entrance.** Installed before major ground disturbance. Reduces tracking mud onto street. Use ODOT #2 stone (1.5 to 2.5 inch diameter), 14' wide, 70' long (30' long for access to an individual house lot) and 6" deep. Geotextile shall be placed over the entire area prior to placing the stone. Water bars may need to be placed to keep water from running into street.

**Storm Drain Inlet Protection.** Installed before earth disturbing activity. Prevents large amounts of silt from entering storm drain. Place geotextile barrier around or across storm drains.

**Temporary Diversions.** Installed before earth disturbing activity. Directs water from site to sediment trap.

**Sediment Trap.** Installed before earth disturbing activity. Stores runoff long enough for sediment to drop into trap. Used when the upslope area exceeds the silt fence capacity and for drainage areas less than 5 acres.

**Leave Stream Buffers in Place.** Tall vegetation (especially trees) stabilized soil along streams and slow storm water runoff. This will protect the stream from erosion.

\*\*For applicants that receive a Storm Water Construction Permit Waiver. All other applicants shall include Sediment and Erosion Control measures in their SWP3.

**Variance Requested**

Items Required for Variance Review

Variance Justification

Variance Request Fee Amount \_\_\_\_\_

Date Variance Granted/Number \_\_\_\_\_

Receipt # \_\_\_\_\_

Date Variance Request Denied \_\_\_\_\_

Initial Block: Planning Dept. \_\_\_\_\_ Health Dept. \_\_\_\_\_ County Engineer's Office \_\_\_\_\_

**Storm Water Construction Permit Renewal or Transfer Requested (Current Permittees Only)**

Renewal or Transfer Fee Amount \_\_\_\_\_ Receipt # \_\_\_\_\_  
Date Renewal or Transfer Granted \_\_\_\_\_ Date Renewal or Transfer Denied \_\_\_\_\_  
Storm Water Construction Permit # \_\_\_\_\_

**Storm Water Construction Permit Amendment Requested (Current Permittees Only)**

Amendment Fee Amount \_\_\_\_\_ Receipt # \_\_\_\_\_  
Date Amendment Granted \_\_\_\_\_ Date Amendment Denied \_\_\_\_\_  
Storm Water Construction Permit # \_\_\_\_\_

**Revision Submittals**

Revision Number \_\_\_\_\_ Date Received \_\_\_\_\_

Revision Number \_\_\_\_\_ Date Received \_\_\_\_\_

Revision Number \_\_\_\_\_ Date Received \_\_\_\_\_

**Certification**

I hereby certify that I understand the provisions of the Wayne County Storm Water Management Regulations and that I accept responsibility for storm water management on the construction site during construction and, as required, after construction. I further grant the right-of-entry onto the proposed project site to the duly authorized agent(s) of Wayne County for the purpose of inspecting for compliance with the Wayne County Storm Water Management Regulations. Neither the District or its representatives, nor the landowner, will be liable for any damage to the other's property in carrying out the provisions of the agreement, unless such damage is caused by negligence or misconduct.

I certify under penalty of law that this document and all the attachments were prepared under my direction or supervision and are to the best of my knowledge and belief, true, accurate and complete.

Zachary Goodson, Director of Gas Operations \_\_\_\_\_ *Zachary R. Goodson* \_\_\_\_\_ 2-21-2024  
Applicant's Printed Name Applicant's Signature Date

\_\_\_\_\_  
Application Received by SWCD Date

**CAP Approval**

\_\_\_\_\_  
Planning Department Date

\_\_\_\_\_  
County Engineer's Office Date

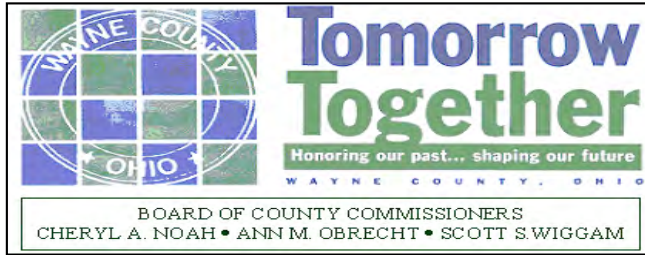
\_\_\_\_\_  
Health Department Date

\_\_\_\_\_  
Wayne Soil and Water Conservation District, Date  
Water Management Engineer

Date Waiver Granted/Number \_\_\_\_\_ Date Waiver Request Denied \_\_\_\_\_

**Attachment 3**  
**Floodplain Permit Application, “No-Impact” Floodway Certification, and**  
**Construction Drawings**





Permit Number: \_\_\_\_\_

# Floodplain Development Permit

Wayne County Planning Department  
428 W. Liberty St. - Wooster, Ohio 44691

**DATE:**  
Submitted \_\_\_\_\_  
Reviewed \_\_\_\_\_  
Reviewer \_\_\_\_\_

**Applicant Name:** The East Ohio Gas Co d/b/a Dominion Energy Ohio  
**Address:** 320 Springside Drive, Suite 320  
Akron, OH 44333

**WARNING AND DISCLAIMER OF LIABILITY:**

The degree of flood protection required by the Wayne County Board of Commissioners' resolution #2003-723 adopted December 23, 2003, is considered reasonable for regulatory purposes and is based on scientific and engineering considerations. Larger floods can and will occur on rare occasion. Flood heights may be increased by man-made or natural causes. Resolution #2003-723 does not imply that land outside the areas of special flood hazards or uses permitted within such areas will be free from flooding or flood damage. Resolution #2003-723 shall not create liability on the part of Wayne County, any officer or employee thereof, or the Federal Emergency Management Agency, for any flood damages that result from reliance on said resolution or any administrative decisions lawfully made thereunder.

**Location of Property**

Township Wooster  
Section S2 T15N R13W  
Quarter Sect. \_\_\_\_\_  
Access Road N. Hillcrest Drive  
House Number \_\_\_\_\_

**F.I.R.M. Number:**

39169C0217E  
Zone: AE / FLOODWAY Year: 2009  
Surveyor: \_\_\_\_\_  
Certification By: \_\_\_\_\_  
Contact Phone: \_\_\_\_\_  
Field Inspection Date: \_\_\_\_\_

**check all that apply:**

	Site Plans/Scale		date reviewed
<input type="checkbox"/> Filling			
<input type="checkbox"/> Grading			
<input checked="" type="checkbox"/> Construction	a. Topography	h. Floodprof Cert.	
<input type="checkbox"/> Alteration	b. Structures	i. Hydrologic Rev.	
<input type="checkbox"/> Remodeling	c. Storage Area	J. Base Flood Elev.	
<input type="checkbox"/> Expanding	d. Drainage Area	K. Compensatory Storage Area	
<input type="checkbox"/> Altering	e. Elevations	L. Post Construction Certification	
<input type="checkbox"/> Watercourse	f. Lowest Floor Elev.		
	g. Scale		

**Nature of Project:**

This project involves the replacement and relocation of approximately 3,100 feet of existing 12-inch pipeline, with approximately 3,900 feet of 12-inch diameter steel pipeline. The existing pipe will be abandoned in place or removed and the new pipe placed in the same trench. Following construction all grades will be restored to their original condition. No changes in elevation or grade will occur within the floodplain.

**Department Comments:**

**Approval Date:** \_\_\_\_\_ **Inspection Date:** \_\_\_\_\_ **Completion Date:** \_\_\_\_\_  
**Applicants Signature:** \_\_\_\_\_ **Date:** \_\_\_\_\_

\*\*\*\*\* OWNER/DEVELOPER IS RESPONSIBLE FOR COMPLIANCE WITH ALL OTHER APPROPRIATE LOCAL, STATE AND FEDERAL REGULATIONS.

**Distribution:**

WHITE-FILE COPY / GREEN-BLDG. DEPT. / YELLOW-HEALTH DEPT. / PINK-APPLICANT COPY / GOLD-OTHER

**ENGINEERING "NO-IMPACT" FLOODWAY CERTIFICATION**

This is to certify that I am a duly qualified engineer licensed to practice in the State of Ohio. It is to further certify that the project to be performed will consist of excavating earth in such a manner that the post construction grade will be at or below the existing pre-construction grade; and the flood heights will not be altered within the floodplain; for the proposed development:

PIR 2788 - Apple Creek in the floodway will not  
*(Name of Development)*

increase the Base Flood Elevations (100-year flood), floodway elevations and the floodway widths on  
Apple Creek at published sections in the Flood Insurance  
*(Name of Stream)*

Study for Wayne County dated 8/18/2009 and will not increase the Base Flood Elevations (100-year flood), floodway elevations, and floodway widths at unpublished cross-sections in the vicinity of the proposed development.

Printed Name Jason Harris, P.E.

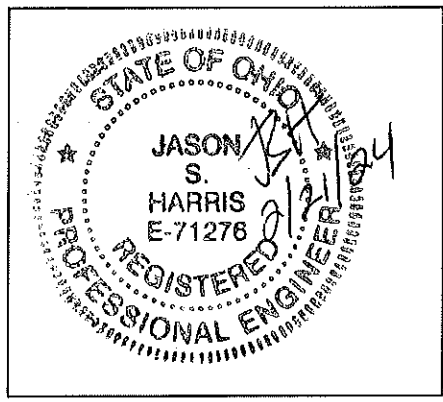
Signature  Date 2/20/2024

Phone Number 330-664-4654 Email Jason.S.Harris@dominionenergy.com

Representing The East Ohio Gas Company, d/b/a Dominion Energy Ohio

Address 320 Springside Drive Suite 320

City Akron State Ohio Zip Code 44333



CERTIFYING SEAL OR STAMP

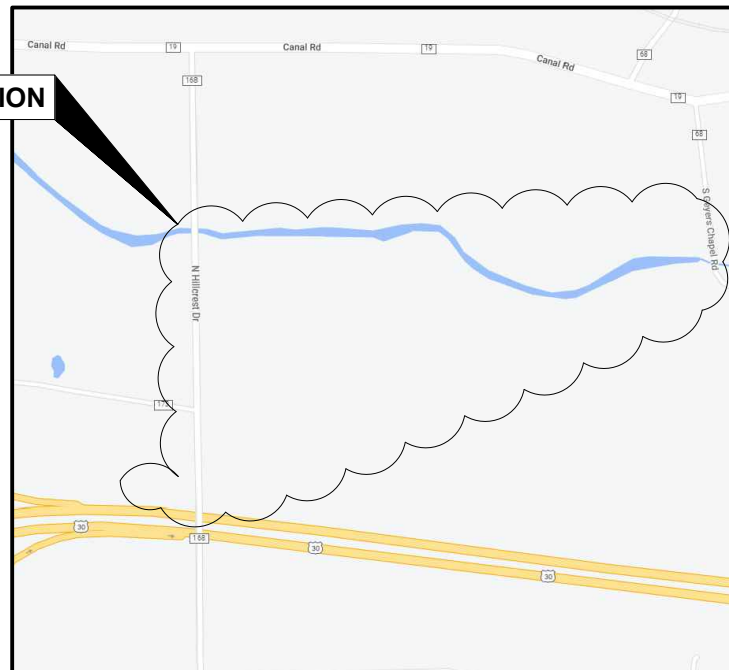
THE OWNER DOES NOT WARRANT THE ACCURACY, SUFFICIENCY, OR COMPLETENESS OF THIS DRAWING OR MAP FOR ANY PURPOSE, AND RELIANCE HEREON AND USE HEREOF IS AT THE RISK OF THE USER WHO AGREES TO HOLD HARMLESS AND INDEMNIFY THE OWNER AGAINST ANY AND ALL LIABILITY IN CONNECTION WITH ITS USE.



## APPLE CREEK - MLR PIR #2788

**WOOSTER TWP., COUNTY OF WAYNE, STATE OF OHIO  
NOTIFICATION #P400243860  
MWO #63449624  
[CWO #]**

**PROJECT LOCATION**



### LOCATION MAP

#### INDEX OF SHEETS

TITLE SHEET .....	1
GENERAL NOTES .....	2
INDEX MAP .....	3
PLAN SHEETS .....	4-16

#### OVERALL HIGH-LEVEL PROJECT SCOPE

THIS PROJECT CONSISTS OF RELOCATING APPROXIMATELY 1022 FEET OF EXISTING HP WITH 3900 FEET OF PROPOSED HP AND ABANDONING AND NOT REPLACING APPROXIMATELY 2075 FEET OF EXISTING HP.

**PROPOSED PIPE FOOTAGES:**  
PROPOSED 12" .375 GrB FBE STL HP - 3890 FEET

#### SYMBOL LEGEND

<ul style="list-style-type: none"> <li> I.P. FOUND</li> <li> MONUMENT BOX</li> <li> BENCHMARK</li> <li> STORM SEWER MANHOLE</li> <li> CURB INLET</li> <li> CATCH BASIN</li> <li> SANITARY SEWER MANHOLE</li> <li> SEPTIC TANK</li> <li> CLEAN OUT</li> <li> WATER MANHOLE</li> <li> WATER METER</li> <li> WATER VALVE</li> <li> FIRE HYDRANT</li> <li> MONITOR WELL</li> <li> LIGHT POLE</li> <li> SUPPORT POLE</li> <li> POWER POLE</li> <li> TELEPHONE POLE</li> <li> GUY</li> <li> TOWER POLE</li> <li> YARD LIGHT</li> <li> RAILROAD CROSSING</li> <li> ELECTRIC MANHOLE</li> <li> ELECTRIC HAND HOLE</li> <li> ELECTRIC METER</li> <li> TRANSFORMER</li> <li> TELEPHONE MANHOLE</li> <li> TELEPHONE PEDESTAL</li> <li> FIBER OPTIC MANHOLE</li> <li> CABLE MANHOLE</li> <li> CABLE BOX</li> <li> UTILITY MANHOLE</li> <li> UTILITY BOX (ELEC,TELE)</li> <li> TRAFFIC BOX</li> <li> TRAFFIC BOX</li> </ul>	<ul style="list-style-type: none"> <li> SATELLITE DISH</li> <li> FLAG POLE</li> <li> ROCK</li> <li> MAIL BOX</li> <li> POST</li> <li> SIGN</li> <li> GAS MARKER</li> <li> ELECTRIC MARKER</li> <li> TELEPHONE MARKER</li> <li> CABLE MARKER</li> <li> ADA RAMP</li> <li> EX. GAS VALVE</li> <li> EX. GAS METER</li> <li> PROP. GAS METER</li> <li> EX. GAS TEST BOX</li> <li> EX. GAS DRIP</li> <li> EX. COUPLING</li> <li> EX. REDUCER</li> <li> EX. END CAP</li> <li> PROP. GAS VALVE</li> <li> PROP. CRITICAL GAS VALVE</li> <li> PROP. REDUCER</li> <li> PROP. CAP</li> <li> PROP. 3-WAY/SPHERICAL TEE</li> <li> PROP. COUPLING</li> <li> PROP. STOPPER</li> <li> CAUSE FOR PAUSE</li> <li> TREE</li> <li> REMOVE</li> <li> EVERGREEN TREE</li> <li> SHRUB</li> <li> STUMP</li> <li> BAT TREE</li> </ul>
--	--

#### GENERAL LINE LEGEND

<ul style="list-style-type: none"> <li>PROPOSED LP GAS LINE</li> <li>PROPOSED MP GAS LINE</li> <li>PROPOSED IP GAS LINE</li> <li>PROPOSED HP GAS LINE</li> <li>PROPOSED TPL GAS LINE</li> <li>PROPOSED STORAGE GAS LINE</li> <li>PROPOSED GATHERING GAS LINE</li> <li>PROPOSED PRODUCTION GAS LINE</li> <li>PROPOSED DEO EASEMENT</li> <li>EXISTING GAS LINE TO BE ABANDONED</li> <li>EXISTING LOW PRESSURE GAS LINE</li> <li>EXISTING MEDIUM PRESSURE GAS LINE</li> <li>EXISTING INTERMEDIATE PRESSURE GAS LINE</li> <li>EXISTING HIGH PRESSURE GAS LINE</li> <li>EXISTING CASING PIPE</li> <li>EXISTING TRANSMISSION LINE</li> <li>EXISTING PRODUCTION GAS LINE</li> <li>EXISTING STORAGE LINE</li> <li>EXISTING GATHERING LINE</li> <li>ABANDONED GAS LINE</li> <li>OVERHEAD UTILITY LINE</li> </ul>	<ul style="list-style-type: none"> <li>PROPERTY LINE</li> <li>CORPORATION LINE</li> <li>EXISTING EASEMENT</li> <li>EXISTING UNDERGROUND STEAM</li> <li>EXISTING UNDERGROUND CHILLER WATER</li> <li>EXISTING UNDERGROUND CABLE</li> <li>EXISTING UNDERGROUND TELEPHONE</li> <li>EXISTING UNDERGROUND ELECTRIC</li> <li>EXISTING UNDERGROUND FIBER OPTICS</li> <li>EXISTING SANITARY SEWER</li> <li>EXISTING STORM SEWER</li> <li>EXISTING WATERMAIN</li> <li>EXISTING GUARDRAIL</li> <li>EXISTING RAILROAD</li> <li>RIGHT OF WAY</li> <li>CENTER LINE</li> <li>EXISTING ROAD PAVEMENT</li> <li>EXISTING WALK/DRIVE</li> <li>FENCE</li> <li>TREE LINE</li> </ul>	<ul style="list-style-type: none"> <li>STEAM</li> <li>CWTR</li> <li>CABLE</li> <li>UT</li> <li>UE</li> <li>UFO</li> <li>SAN</li> <li>STM</li> <li>WTR</li> <li>R/W</li> <li>1+00</li> <li>X-X-X</li> <li>Tree Line Symbol</li> </ul>
---	--	--

#### CONTACTS

**PROJECT MANAGER:**  
DAVE HOLLENDONNER - 330-203-2186

**DESIGN COORDINATOR:**  
ALEX GNAP - 330-571-4062

**DESIGNER:**  
NEFF & ASSOCIATES

**CONTRACTOR INSPECTION:**  
MATT REYNOLDS - 330-697-9840

**MUNICIPALITY(IES):**  
WOOSTER TWP - 330-264-4435

**ENVIRONMENTAL:**  
DAVE FREDLE - 330-703-3603

**LAND SERVICES:**  
KYLE ROUDEBUSH - 330-590-7736

**CORROSION:**  
AUSTIN SPEED - 216-317-4486

**IN CASE OF EMERGENCY CALL 9-1-1, THEN:**  
PRIMARY EMERGENCY LINE FOR CUSTOMERS 877-542-2630

REFER TO MATERIAL LIST OR BID SHEET(S) FOR ACTUAL QUANTITIES.  
CONTACT PROJECT MANAGER FOR QUESTIONS.



1-800-362-2764 or 811

#### CAUSE FOR PAUSE

SIGNIFICANT/CRITICAL ITEMS REQUIRING CAUTION APPLY TO THIS PROJECT AND REQUIRE AN **ONSITE** PRE-CONSTRUCTION MEETING BY DESIGN AND CONSTRUCTION.

#### PIPELINE INFORMATION TABLE

PRESS.	SYS. ID.	PCB ZONE	SYSTEM MAOP	TESTING
HIGH	WOH6	GREEN	249.0 psi	PRESSURE TESTING SHALL BE IN ACCORDANCE WITH DEO SOP

<b>MUNICIPALITY:</b> Wooster Twp, Triway LSD	
<b>INV. DIV.</b> 990	<b>COUNTY:</b> WAYNE
<b>OPERATING AREA:</b> WOOSTER	<b>COORD:</b> 40.804562, -81.895694
<b>CLASS LOCATION:</b> 3	<b>DESIGN CLASS LOCATION:</b> 3
<b>XRAY:</b> 100%	<b>WELL NO:</b> #
<b>FACILITY ID:</b> 12980000-18	<b>REGULATOR NO:</b> #
<b>SPECIFIED MINIMUM YIELD STRENGTH (SMYS):</b> 13.6%	

OHIO UTILITIES PROTECTION SERVICE  
2 WORKING DAYS BEFORE YOU DIG  
CALL TOLL FREE 1-800-362-2764



DATE	BY	DESCRIPTION



PIR 2788 APPLE CREEK  
WOOSTER TWP., WAYNE CNTY

TITLE SHEET

DATE: 2/19/2024  
PROJECT ID #: P400243860

1  
16



THE OWNER DOES NOT WARRANT THE ACCURACY, SUFFICIENCY, OR COMPLETENESS OF THIS DRAWING OR MAP FOR ANY PURPOSE, AND RELIANCE HEREON AND USE HEREOF IS AT THE RISK OF THE USER, WHO AGREES TO HOLD HARMLESS AND INDEMNIFY THE OWNER AGAINST ANY AND ALL LIABILITY IN CONNECTION WITH ITS USE.

**GENERAL NOTES**

- CONTRACTOR MUST MAINTAIN A SAFE WALKWAY FOR PEDESTRIAN TRAVELING THROUGH THE WORK ZONE.
- INGRESS AND EGRESS TO DRIVEWAYS TO BE MAINTAINED WHEN PRACTICAL FOR CONSTRUCTION.
- DEO CONTRACTOR IS TO FOLLOW PCB PIPELINE GUIDELINES:
- ALL PAVEMENT OPENINGS TO BE RESTORED PER WOOSTER TWP. REQUIREMENTS.
- ALL RESTORATION MUST BE COMPLETED IMMEDIATELY AFTER GAS MAIN INSTALLATION.
- CONTRACTOR IS RESPONSIBLE FOR ALL TEMPORARY RESTORATION AND ITS MAINTENANCE UNTIL FINAL RESTORATION IS COMPLETE.
- WOOSTER TWP TO BE CONTACTED 2 WORKING DAYS BEFORE START OF CONSTRUCTION. CALL CALL NATHAN WILLIAMS AT 330-264-4435.
- CONTRACTOR MUST CALL OUPS AT LEAST TWO (2) WORKING DAYS BEFORE STARTING WORK.
- ONE LANE OF TRAFFIC MUST BE MAINTAINED IN BOTH DIRECTIONS DURING NON-CONSTRUCTION HOURS.
- SUPPORTING OF EXISTING UTILITY POLES DURING CONSTRUCTION IS THE RESPONSIBILITY OF THE CONTRACTOR, INCLUDING MAKING THE ARRANGEMENTS WITH THE 3RD PARTY TO COORDINATE THE WORK.
- CONTRACTOR TO GAUGE LINES AND USE DOUBLE BYPASSES AS REQUIRED.
- CONTRACTOR SHALL ADHERE TO ALL ASPECTS OF THE DEO CORROSION POLICY WHEN WORKING ON STEEL MAINS AND SERVICES.
- DEO WILL PAY FOR ANY AND ALL NON-DESTRUCTIVE TESTING (NDT) OF WELDS. THE CONTRACTOR SHALL ASSIST THE NDT CONTRACTOR WHERE NEEDED AT NO ADDITIONAL COST TO DEO
- ALL GAS WORK SHALL BE COMPLETED IN ACCORDANCE WITH THE CURRENT VERSION OF DOMINION SPECIFICATIONS AND PROCEDURES, INCLUDING BUT NOT LIMITED TO:
  - DOMINION STANDARD OPERATING PROCEDURES (SOP)
  - DOMINION DESIGN & CONSTRUCTION MANUAL (D&C)
  - DOMINION GENERAL CONSTRUCTION REQUIREMENTS
- ALL MATERIAL AND FABRICATION SHALL MEET OR EXCEED CURRENT VERSIONS OF INDUSTRY SPECIFICATIONS AND PROCEDURES, INCLUDING BUT NOT LIMITED TO:
  - ANSI, API, AND ASTM SPECIFICATIONS
- ALL NON-GAS RELATED SITE AND RESTORATION WORK SHALL BE COMPLETED IN ACCORDANCE WITH APPLICABLE JURISDICTIONAL REQUIREMENTS.

**MAINTENANCE OF TRAFFIC**

ALL TRAFFIC MAINTENANCE SHALL BE PERFORMED IN ACCORDANCE WITH THE REQUIREMENTS OF:  
THE OHIO MANUAL OF UNIFORM TRAFFIC CONTROL DEVICES FOR STREETS AND HIGHWAYS.  
 INCLUDING BUT NOT EXCLUSIVE OF O.R.C 614.02, 614.03

1. THE CONTRACTOR SHALL CONTACT THE APPROPRIATE TRAFFIC CONTROL PROVIDER (TCP) AT LEAST 48 HOURS IN ADVANCE:  
 AWP (YOUNGSTOWN, ASHTABULA, AKRON, CANTON & WOOSTER) - 800-343-2650  
 WD WRIGHT (NORTHEAST, EASTERN, WESTERN, MARIETTA, NEW PHILADELPHIA, AKRON, CANTON & WOOSTER) - 330-472-3220.  
 WD WRIGHT (LIMA) - 419-280-7985.  
 SOUTHPOINTE (YOUNGSTOWN, ASHTABULA, NORTHERN, EASTERN & WESTERN) - 412-765-9201.  
 BOLON (MARIETTA & NEW PHILADELPHIA) - 740-567-4102.  
 ZONE SAFETY (LIMA) - 440-752-9545
2. CONTRACTOR IS RESPONSIBLE TO COORDINATE, SCHEDULE AND CANCEL TRAFFIC CONTROL WITH TCP AND THE RESPECTIVE MUNICIPALITY AND/OR JURISDICTIONAL ENTITY. CANCELING OF TRAFFIC CONTROL WITH THE TCP IS REQUIRED TO BE DONE A MINIMUM OF 1 HOUR BEFORE THE ESTABLISHED JOB START TIME TO AVOID PENALTY. IF CONTRACTOR CANCELS OR SHUTS DOWN FOR ANY REASON, AND FAILS TO CANCEL WITH TCP PRIOR TO THE MINIMUM ADVANCE NOTICE, THE CONTRACTOR IS RESPONSIBLE FOR PAYMENT TO TCP. DEO FIELD INSPECTOR TO DOCUMENT THIS ON CURRENT TCP/TRAFFIC CONTROL AS-BUILT PAPERWORK.

**GAS PLANNING - GAS FEED DISCLAIMER:**

1. GAS FEED INFORMATION PROVIDED WAS OBTAINED FROM GAS PLANNING AND REPRESENTS "TYPICAL FLOW" UNDER NORMAL OPERATING CONDITIONS.
2. GAS FEED INFORMATION AS SHOWN AT TIE-IN LOCATIONS IS FOR REFERENCE ONLY AND MUST NOT BE USED IN DETERMINING THE NEED FOR BY-PASS PROCEDURES.
3. GAS PLANNING MUST BE CONSULTED TO VERIFY FEED AT TIME OF CONSTRUCTION.

**CORROSION:**

FOR ALL TEST POINTS INSTALLED OR RE-INSTALLED, DEO INSPECTOR TO OBTAIN PIPE-TO-SOIL READING. IF READING CANNOT BE ACHIEVED OR FALLS BELOW -0.850 VOLTS, DEO INSPECTOR TO CONTACT DEO CORROSION TO DETERMINE ANODE PLACEMENT.

**POST-CONSTRUCTION RESTORATION REQUIREMENTS**

[DETAILED DESCRIPTION FOR RESTORATION REQUIREMENTS] DELETE IF NOT NEEDED

**UTILITY OWNERSHIPS ARE AS FOLLOWS:**

<b>OHIO UTILITIES PROTECTION SERVICE:</b>	<b>American Electric Power (AEP) Ohio:</b>
ADDRESS 4740 Belmont Ave.	ADDRESS 301 Cleveland Avenue SW
CITY Youngstown, Ohio 44505	CITY Canton, Ohio 44702
PHONE: 1-800-362-2764	PHONE: 330-438-7741
CONTACT: Tom Hackstedde - Supervisor	CONTACT: David M. Wheeler

**ILLUMINATING COMPANY:**  
 ADDRESS 1910 W. Market Street  
 CITY Akron, Ohio 44313  
 PHONE: 330-436-4153  
 CONTACT: David Miller - Engineering

**CENTURY LINE:**  
 ADDRESS 441 W. Broad Street  
 CITY Pataskala, Ohio 43062  
 PHONE: 330-886-1299  
 CONTACT: Chris Strayer

REV	DESCRIPTION	DATE	BY

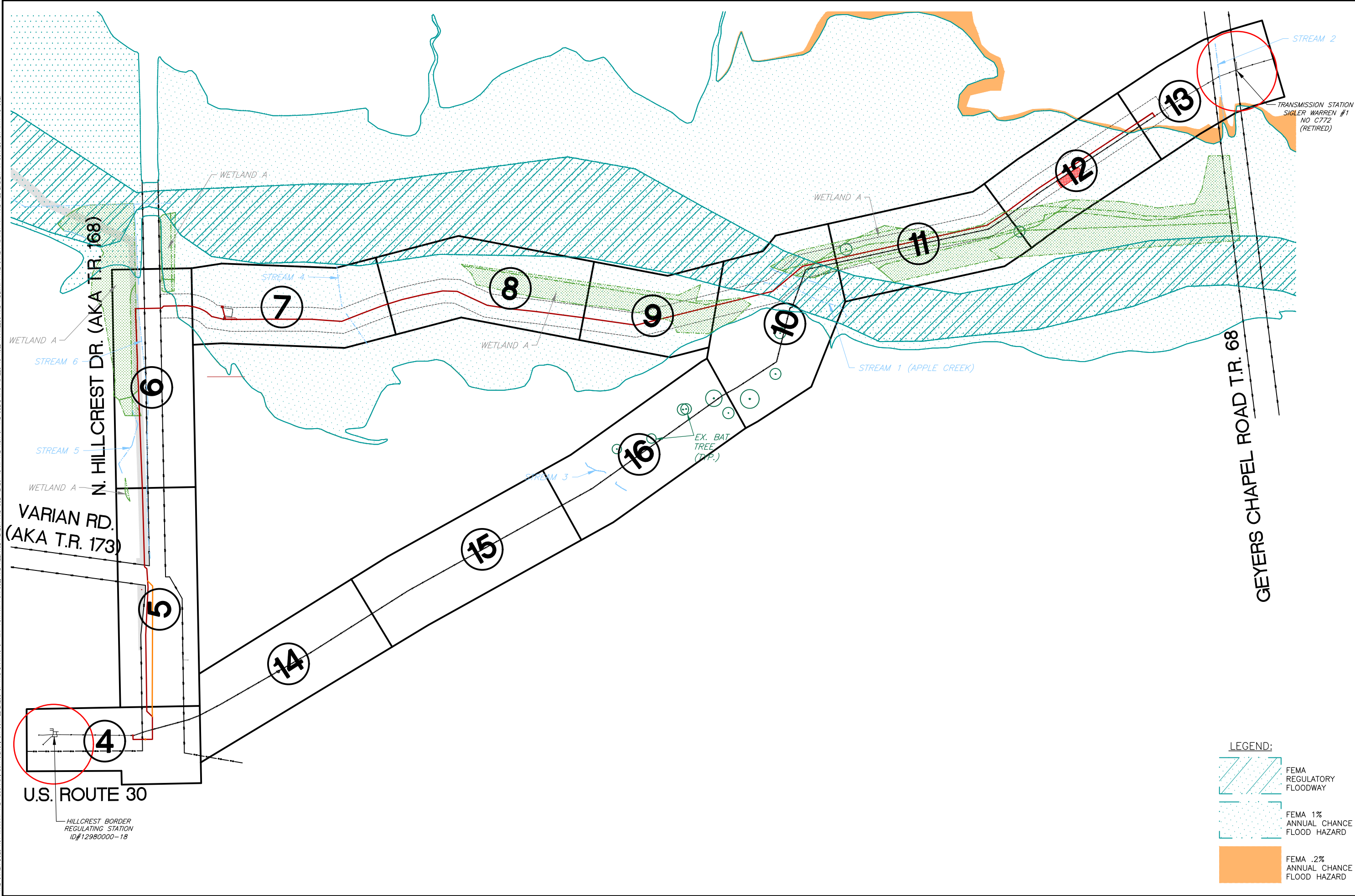


**PIR 2788 APPLE CREEK  
WOOSTER TWP., WAYNE CNTY**

**NOTE SHEET**

DATE: 2/19/2024  
PROJECT ID #: **P400243860**

THE OWNER DOES NOT WARRANT THE ACCURACY, SUFFICIENCY, OR COMPLETENESS OF THIS DRAWING OR MAP FOR ANY PURPOSE, AND RELIANCE HEREON AND USE HEREOF IS AT THE RISK OF THE USER, WHO AGREES TO HOLD HARMLESS AND INDEMNIFY THE OWNER AGAINST ANY AND ALL LIABILITY IN CONNECTION WITH ITS USE.



NORTH

DRAWING SCALE  
0 110' 220'

REV	DESCRIPTION	DATE	BY

**Dominion Energy**

**PIR 2788 APPLE CREEK  
WOOSTER TWP., WAYNE CNTY**

**INDEX MAP**

DATE: 2/19/2024	PROJECT ID #: <b>P400243860</b>
<b>3</b>	<b>16</b>

- LEGEND:**
- FEMA REGULATORY FLOODWAY
  - FEMA 1% ANNUAL CHANCE FLOOD HAZARD
  - FEMA .2% ANNUAL CHANCE FLOOD HAZARD

**U.S. ROUTE 30**

HILLCREST BORDER REGULATING STATION  
ID#12980000-18

**VARIAN RD.  
(AKA T.R. 173)**

**N. HILLCREST DR. (AKA T.R. 168)**

**GEYERS CHAPEL ROAD T.R. 68**

TRANSMISSION STATION  
SIGLER WARREN #1  
NO C772  
(RETIRED)

THE OWNER DOES NOT WARRANT THE ACCURACY, SUFFICIENCY, OR COMPLETENESS OF THIS DRAWING OR MAP FOR ANY PURPOSE, AND RELIANCE HEREON AND USE HEREOF IS AT THE RISK OF THE USER, WHO AGREES TO HOLD HARMLESS AND INDEMNIFY THE OWNER AGAINST ANY AND ALL LIABILITY IN CONNECTION WITH ITS USE.

CAUSE FOR PAUSE CRITICAL ITEMS	
ITEM #	DESCRIPTION
4-1	CAUTION: PROP. 12" HP CROSSING EX. 12" HP. CONTRACTOR TO VERIFY DEPTH & LOCATION BEFORE CROSSING.
4-2	CAUTION: PROP. 12" HP CROSSING POSS. EX. 36" STM SEWER. CONTRACTOR TO VERIFY DEPTH & LOCATION BEFORE CROSSING.

NORTH

DRAWING SCALE  
0 20' 40'

REV	DESCRIPTION	DATE	BY

**Dominion Energy**

**PIR 2788 APPLE CREEK  
WOOSTER TWP., WAYNE CNTY**

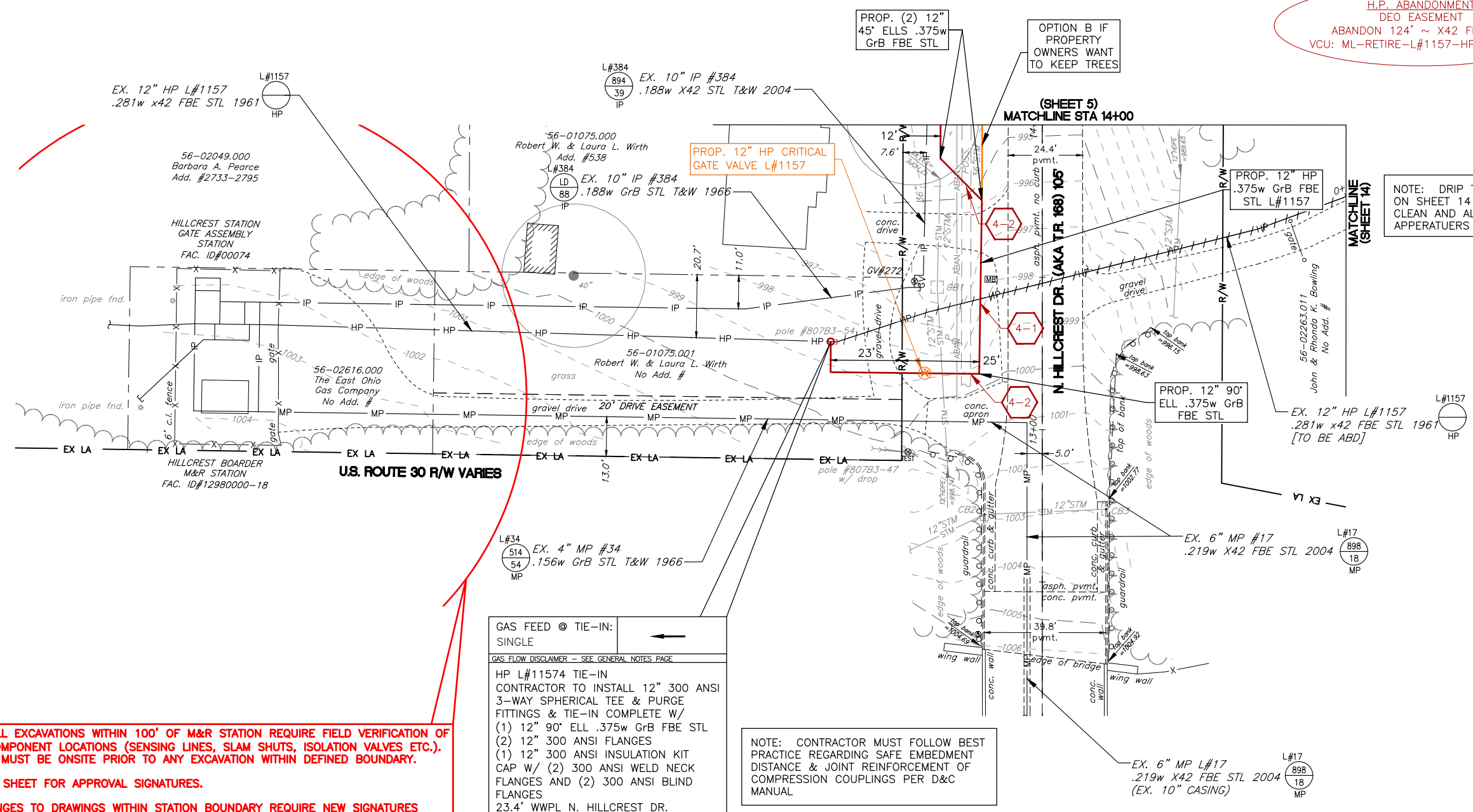
**HILLCREST  
BOARDER  
STATION**

DATE: 2/19/2024  
PROJECT ID #: **P400243860**

**4**  
**16**

H.P.  
E.S. N. HILLCREST DR.  
INSTALL 145' - 12" .375w GrB FBE STL  
VCU: ML REPL-L#1157-HP-OH15369

H.P. ABANDONMENT  
DEO EASEMENT  
ABANDON 124' ~ X42 FBE STL  
VCU: ML-RETIRE-L#1157-HP-OH15369



**CAUTION: ALL EXCAVATIONS WITHIN 100' OF M&R STATION REQUIRE FIELD VERIFICATION OF CRITICAL COMPONENT LOCATIONS (SENSING LINES, SLAM SHUTS, ISOLATION VALVES ETC.). DEO GM&R MUST BE ONSITE PRIOR TO ANY EXCAVATION WITHIN DEFINED BOUNDARY.**

**SEE COVER SHEET FOR APPROVAL SIGNATURES.**

**\* ANY CHANGES TO DRAWINGS WITHIN STATION BOUNDARY REQUIRE NEW SIGNATURES**

**GAS FEED @ TIE-IN:**  
SINGLE

GAS FLOW DISCLAIMER - SEE GENERAL NOTES PAGE

HP L#11574 TIE-IN  
CONTRACTOR TO INSTALL 12" 300 ANSI 3-WAY SPHERICAL TEE & PURGE FITTINGS & TIE-IN COMPLETE W/  
(1) 12" 90° ELL .375w GrB FBE STL  
(2) 12" 300 ANSI FLANGES  
(1) 12" 300 ANSI INSULATION KIT CAP W/ (2) 300 ANSI WELD NECK FLANGES AND (2) 300 ANSI BLIND FLANGES  
23.4' WWPL N. HILLCREST DR.  
38.7' NNPL US ROUTE 30  
FB #NA, STA. NA  
INSTALL TEST BOX & 17# ANODE, RETAIN T234-225.1

NOTE: CONTRACTOR MUST FOLLOW BEST PRACTICE REGARDING SAFE EMBEDMENT DISTANCE & JOINT REINFORCEMENT OF COMPRESSION COUPLINGS PER D&C MANUAL

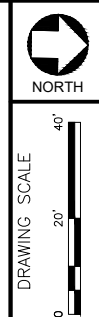
**CORROSION NOTE:** ALL ANODES INSTALLED SHOULD BE NO MORE THAN 500' APART AND TEST BOXES INSTALLED NO MORE THAN 1000'.

- CB1  
EX. STM INLET  
RIM:995.33  
INV:993.73(-1.6)(12"V)  
INV:993.58(-1.75)(12"S)
- CB2  
EX. STM INLET  
RIM:1002.82  
INV:999.32(-3.5)(12"SW&E)
- CB3  
EX. STM INLET  
RIM:1002.69  
INV:999.24(-3.45)(12"W)



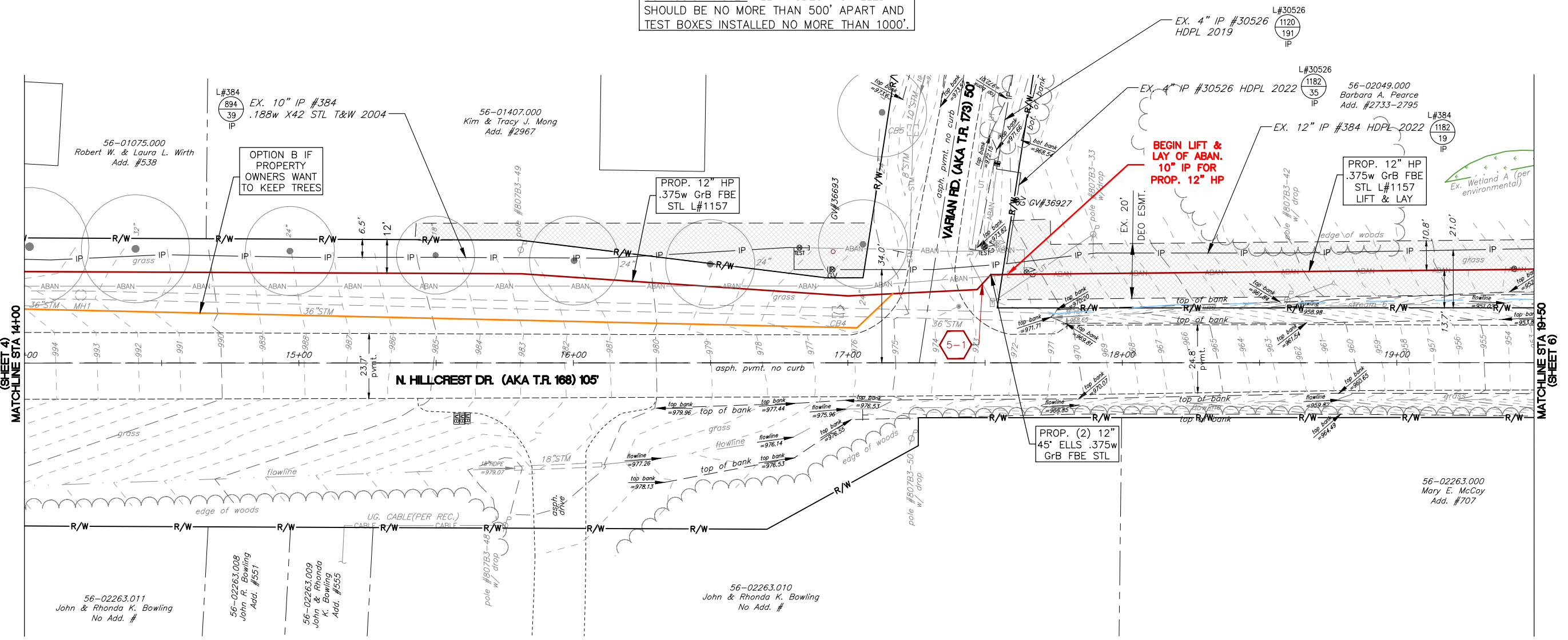
**CAUSE FOR PAUSE CRITICAL ITEMS**

ITEM #	DESCRIPTION
5-1	CAUTION: PROP. 12" HP EX. UG TELEPHONE. CONTRACTOR TO VERIFY DEPTH & LOCATION BEFORE CROSSING.



H.P.  
E.S. N. HILLCREST DR.  
INSTALL 360' - 12" .375w GrB FBE STL  
LIFT & LAY 195' - 12" .375w GrB FBE STL  
VCU: ML REPL-L#1157-HP-OH15369

**CORROSION NOTE:** ALL ANODES INSTALLED SHOULD BE NO MORE THAN 500' APART AND TEST BOXES INSTALLED NO MORE THAN 1000'.



THE OWNER DOES NOT WARRANT THE ACCURACY, SUFFICIENCY, OR COMPLETENESS OF THIS DRAWING OR MAP FOR ANY PURPOSE, AND RELIANCE HEREON AND USE HEREOF IS AT THE RISK OF THE USER, WHO AGREES TO HOLD HARMLESS AND INDEMNIFY THE OWNER AGAINST ANY AND ALL LIABILITY IN CONNECTION WITH ITS USE.

MH1  
EX. STM MH  
RIM: 992.24  
INV: 974.03(-18.21)(36"N&S)

CB4  
EX. STM INLET  
RIM: 974.89  
INV: 969.20(-5.69)(36"N)  
INV: 969.48(-5.41)(36"S)

CB5  
EX. STM INLET  
RIM: 971.72  
INV: 969.54(-2.18)(10"W)  
INV: 969.40(-2.32)(8"E)

NOTE: CONTRACTOR MUST FOLLOW BEST PRACTICE REGARDING SAFE EMBEDMENT DISTANCE & JOINT REINFORCEMENT OF COMPRESSION COUPLINGS PER D&C MANUAL

REV#	DESCRIPTION	DATE	BY



PIR 2788 APPLE CREEK  
WOOSTER TWP., WAYNE CNTY

HILLCREST DRIVE  
14+00 to 19+50

DATE: 2/19/2024  
PROJECT ID #: P400243860

5  
16

THE OWNER DOES NOT WARRANT THE ACCURACY, SUFFICIENCY, OR COMPLETENESS OF THIS DRAWING OR MAP FOR ANY PURPOSE, AND RELIANCE HEREON AND USE HEREOF IS AT THE RISK OF THE USER, WHO AGREES TO HOLD HARMLESS AND INDEMNIFY THE OWNER AGAINST ANY AND ALL LIABILITY IN CONNECTION WITH ITS USE.

EX. STM INLET  
RIM: 1103.60  
TOP DEBRIS: 1103.00(-0.6)  
NO VISIBLE PIPES

Source Dwg: N:\LAND DEVELOPMENT\Proj\14500A-014 DEO PIR 2788 Apple Creek--Wooster Twp\dwg\14500A-014-C3D-C14.dwg Date: Feb 19 2024; 9:05AM Owner: Ivarga

**LEGEND:**

- FEMA 1% ANNUAL CHANCE FLOOD HAZARD
- FEMA .2% ANNUAL CHANCE FLOOD HAZARD

H.P.  
E.S. N. HILLCREST DR.  
INSTALL 145' - 12" .375w GrB FBE STL  
LIFT & LAY 455' - 12" .375w GrB FBE STL  
VCU: ML REPL-L#1157-HP-OH15369

**CORROSION NOTE:** ALL ANODES INSTALLED SHOULD BE NO MORE THAN 500' APART AND TEST BOXES INSTALLED NO MORE THAN 1000'. TEST POINTS INSTALLED ALONG THE MAINLINE SHALL BE LOCATED TO THE EDGE OF THE EASEMENTS, FENCE LINES, OR TREE LINES TO AVOID PEDESTAL IN THE MIDDLE OF THE FIELD.

NOTE: ALL DISTURBANCES WITHIN THE FLOOD PLAN MUST BE RETURNED TO PRECONSTRUCTION CONTOURS.

NORTH

DRAWING SCALE  
0 20' 40'

REV#	DESCRIPTION	DATE	BY

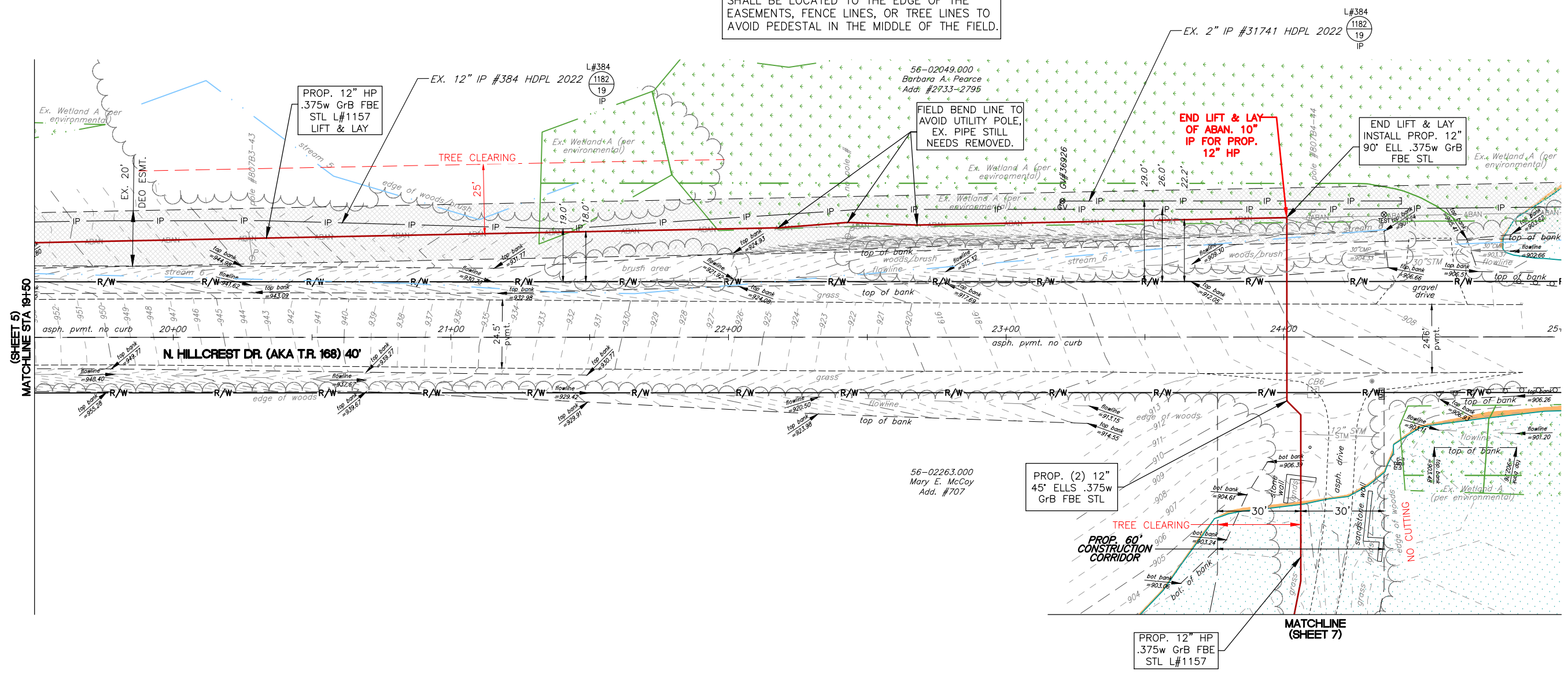
**Dominion Energy**

**PIR 2788 APPLE CREEK  
WOOSTER TWP., WAYNE CNTY**

**HILLCREST DRIVE  
19+50 to 25+00**

DATE: 2/19/2024  
PROJECT ID #: **P400243860**

**6**  
**16**



(SHEET 5)  
MATCHLINE STA 19+50

MATCHLINE  
(SHEET 7)

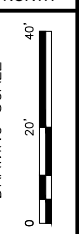
NOTE: CONTRACTOR MUST FOLLOW BEST PRACTICE REGARDING SAFE EMBEDMENT DISTANCE & JOINT REINFORCEMENT OF COMPRESSION COUPLINGS PER D&C MANUAL

THE OWNER DOES NOT WARRANT THE ACCURACY, SUFFICIENCY, OR COMPLETENESS OF THIS DRAWING OR MAP FOR ANY PURPOSE, AND RELIANCE HEREON AND USE HEREOF IS AT THE RISK OF THE USER, WHO AGREES TO HOLD HARMLESS AND INDEMNIFY THE OWNER AGAINST ANY AND ALL LIABILITY IN CONNECTION WITH ITS USE.

**LEGEND:**

FEMA 1% ANNUAL CHANCE FLOOD HAZARD  
FEMA REGULATORY FLOODWAY

NOTE: ALL DISTURBANCES WITHIN THE FLOOD PLAIN MUST BE RETURNED TO PRECONSTRUCTION CONTOURS, EXCEPT WHERE NOTED AS INSTALL GRAVEL TURN AROUND, DRIP RISER, AND BOLLARDS.



REV	DESCRIPTION	DATE	BY

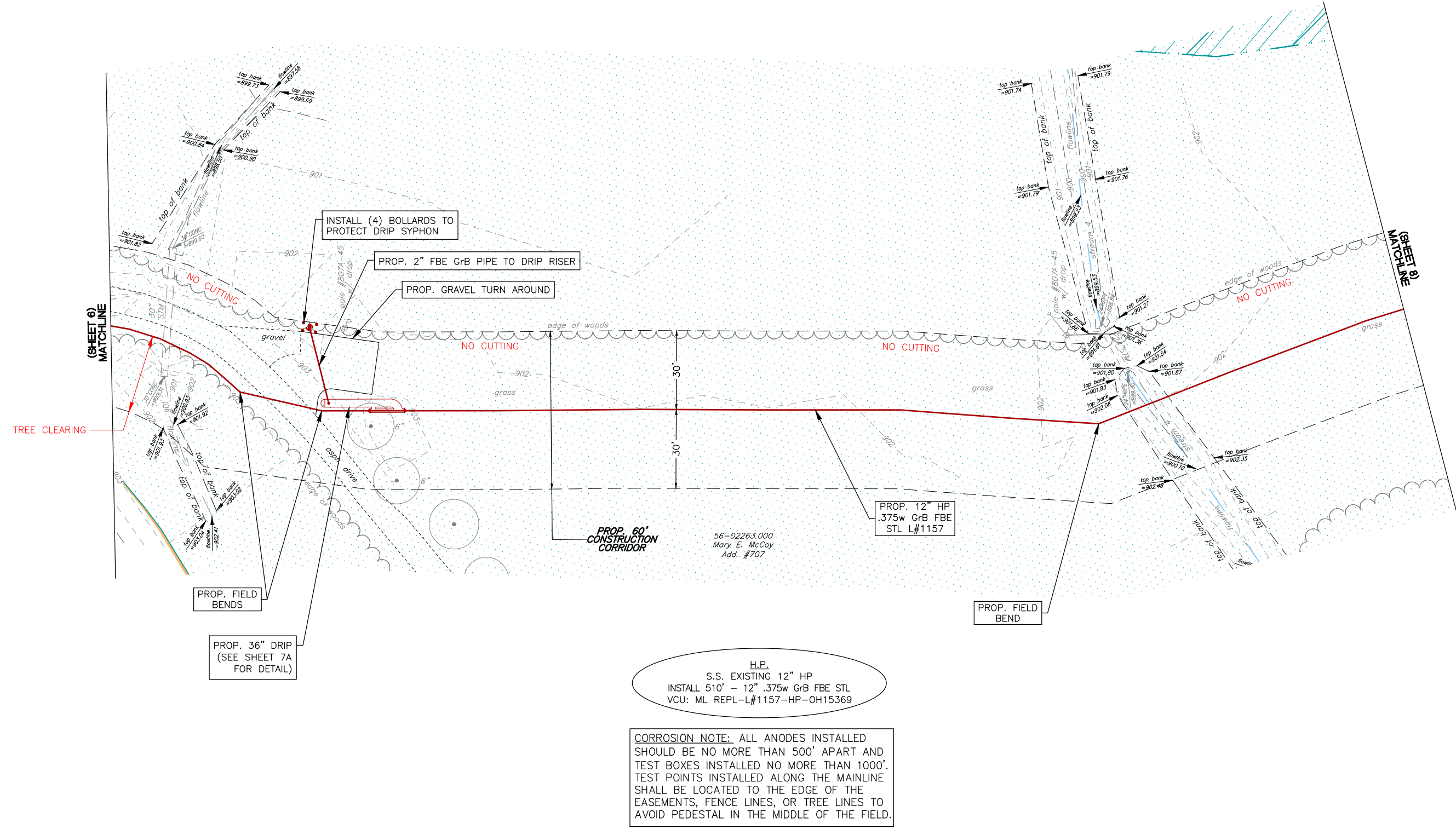


**PIR 2788 APPLE CREEK  
WOOSTER TWP., WAYNE CNTY**

**DEO EASEMENT**

DATE: 2/19/2024  
PROJECT ID #: **P400243860**

**7**  
**16**



**H.P.**  
S.S. EXISTING 12" HP  
INSTALL 510' - 12" .375w GrB FBE STL  
VCU: ML REPL-L#1157-HP-OH15369

**CORROSION NOTE:** ALL ANODES INSTALLED SHOULD BE NO MORE THAN 500' APART AND TEST BOXES INSTALLED NO MORE THAN 1000'. TEST POINTS INSTALLED ALONG THE MAINLINE SHALL BE LOCATED TO THE EDGE OF THE EASEMENTS, FENCE LINES, OR TREE LINES TO AVOID PEDESTAL IN THE MIDDLE OF THE FIELD.



THE OWNER DOES NOT WARRANT THE ACCURACY, SUFFICIENCY, OR COMPLETENESS OF THIS DRAWING OR MAP FOR ANY PURPOSE, AND RELIANCE HEREON AND USE HEREOF IS AT THE RISK OF THE USER, WHO AGREES TO HOLD HARMLESS AND INDEMNIFY THE OWNER AGAINST ANY AND ALL LIABILITY IN CONNECTION WITH ITS USE.



 NORTH	DRAWING SCALE 	REV	DESCRIPTION	DATE	BY

  
**PIR 2788 APPLE CREEK  
WOOSTER TWP., WAYNE CNTY**
  
**DRIP DESIGN  
DETAIL**
  


DATE: 2/19/2024
PROJECT ID #: <b>P400243860</b>


  

<b>7A</b>
<b>16</b>


THE OWNER DOES NOT WARRANT THE ACCURACY, SUFFICIENCY, OR COMPLETENESS OF THIS DRAWING OR MAP FOR ANY PURPOSE, AND RELIANCE HEREON AND USE HEREOF IS AT THE RISK OF THE USER, WHO AGREES TO HOLD HARMLESS AND INDEMNIFY THE OWNER AGAINST ANY AND ALL LIABILITY IN CONNECTION WITH ITS USE.

**LEGEND:**

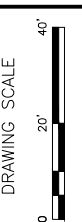
 FEMA 1% ANNUAL CHANCE FLOOD HAZARD

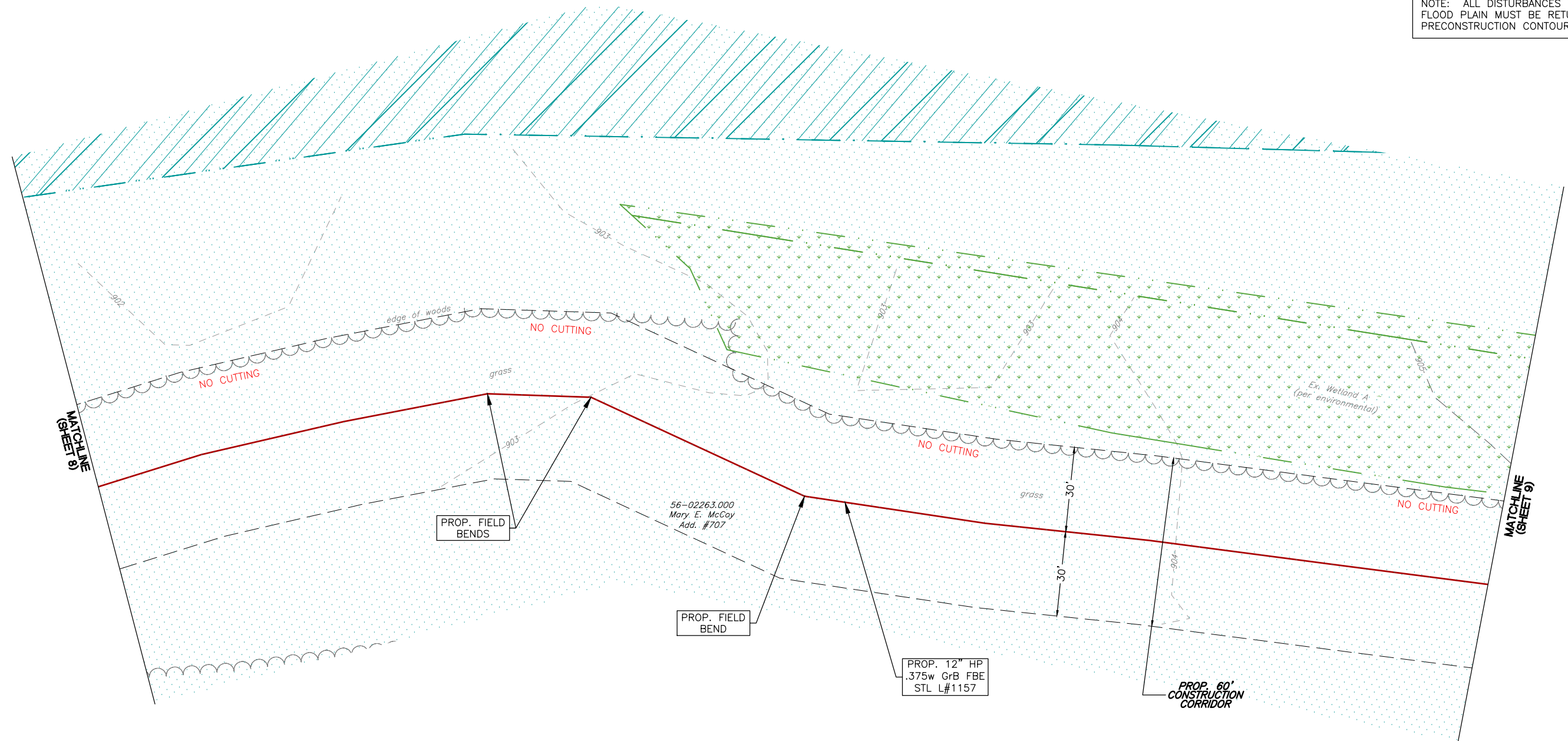
 FEMA REGULATORY FLOODWAY

NOTE: ALL DISTURBANCES WITHIN THE FLOOD PLAIN MUST BE RETURNED TO PRECONSTRUCTION CONTOURS.

 NORTH

DRAWING SCALE





PROP. FIELD BENDS

PROP. FIELD BEND

PROP. 12" HP  
.375w GrB FBE  
STL L#1157

PROP. 60'  
CONSTRUCTION  
CORRIDOR

H.P.  
S.S. EXISTING 12" HP  
INSTALL 505' - 12" .375w GrB FBE STL  
VCU: ML REPL-L#1157-HP-OH15369

**CORROSION NOTE:** ALL ANODES INSTALLED SHOULD BE NO MORE THAN 500' APART AND TEST BOXES INSTALLED NO MORE THAN 1000'. TEST POINTS INSTALLED ALONG THE MAINLINE SHALL BE LOCATED TO THE EDGE OF THE EASEMENTS, FENCE LINES, OR TREE LINES TO AVOID PEDESTAL IN THE MIDDLE OF THE FIELD.

REV	DESCRIPTION	DATE	BY



PIR 2788 APPLE CREEK  
WOOSTER TWP., WAYNE CNTY

DEO EASEMENT

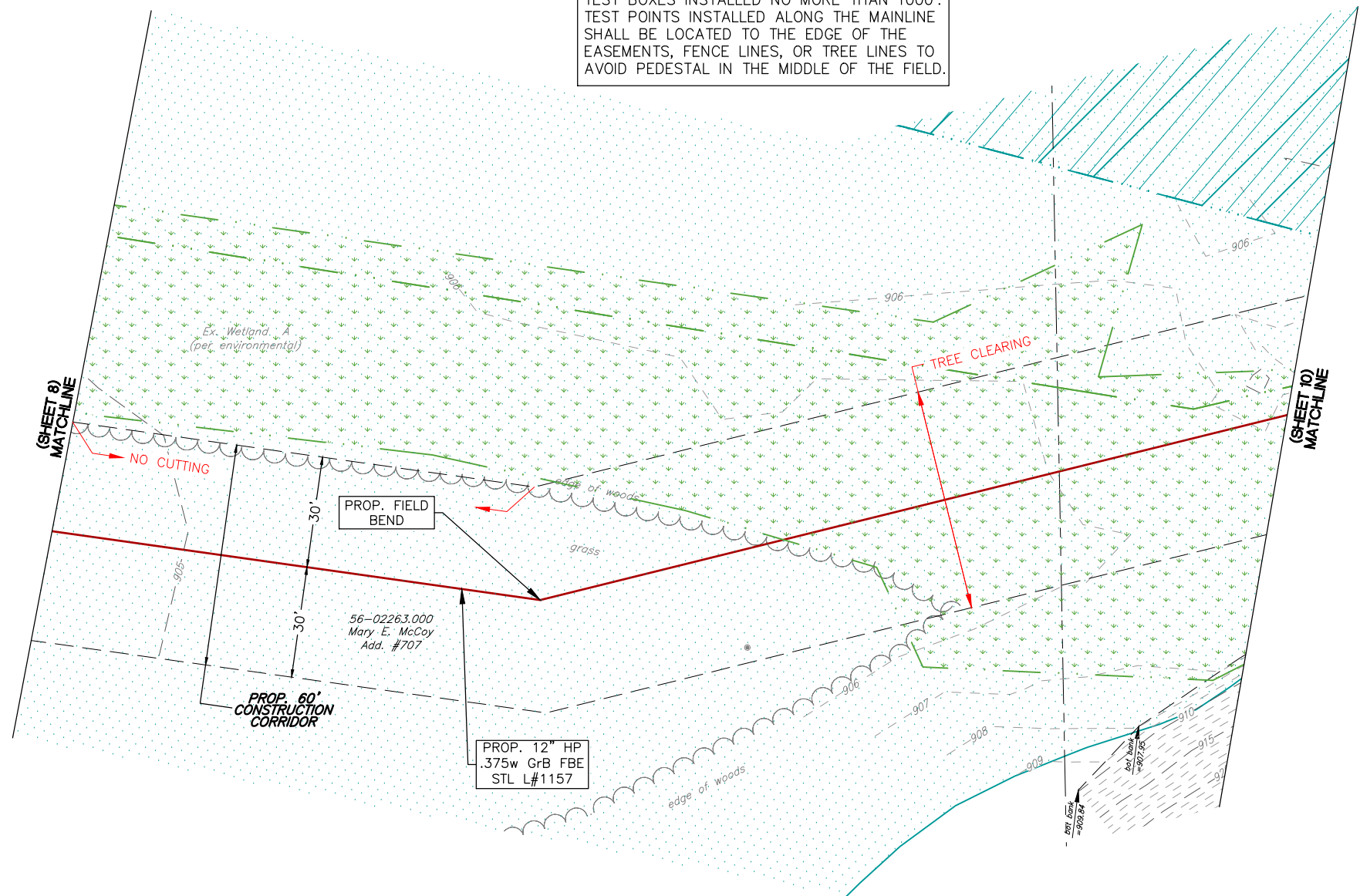
DATE: 2/19/2024  
PROJECT ID #: P400243860

8  
16

THE OWNER DOES NOT WARRANT THE ACCURACY, SUFFICIENCY, OR COMPLETENESS OF THIS DRAWING OR MAP FOR ANY PURPOSE, AND RELIANCE HEREON AND USE HEREOF IS AT THE RISK OF THE USER, WHO AGREES TO HOLD HARMLESS AND INDEMNIFY THE OWNER AGAINST ANY AND ALL LIABILITY IN CONNECTION WITH ITS USE.

H.P.  
DEO EASEMENT  
INSTALL 345' - 12" .375w GrB FBE STL  
VCU: ML REPL-L#1157-HP-OH15369

**CORROSION NOTE:** ALL ANODES INSTALLED SHOULD BE NO MORE THAN 500' APART AND TEST BOXES INSTALLED NO MORE THAN 1000'. TEST POINTS INSTALLED ALONG THE MAINLINE SHALL BE LOCATED TO THE EDGE OF THE EASEMENTS, FENCE LINES, OR TREE LINES TO AVOID PEDESTAL IN THE MIDDLE OF THE FIELD.



**LEGEND:**

- FEMA 1% ANNUAL CHANCE FLOOD HAZARD (dotted pattern)
- FEMA REGULATORY FLOODWAY (hatched pattern)

NOTE: ALL DISTURBANCES WITHIN THE FLOOD PLAIN MUST BE RETURNED TO PRECONSTRUCTION CONTOURS.

**NORTH**

DRAWING SCALE

REV	DESCRIPTION	DATE	BY



PIR 2788 APPLE CREEK  
WOOSTER TWP., WAYNE CNTY

DEO EASEMENT

DATE: 2/19/2024  
PROJECT ID #: P400243860

9  
16



THE OWNER DOES NOT WARRANT THE ACCURACY, SUFFICIENCY, OR COMPLETENESS OF THIS DRAWING OR MAP FOR ANY PURPOSE, AND RELIANCE HEREON AND USE HEREOF IS AT THE RISK OF THE USER, WHO AGREES TO HOLD HARMLESS AND INDEMNIFY THE OWNER AGAINST ANY AND ALL LIABILITY IN CONNECTION WITH ITS USE.

H.P.  
DEO EASEMENT  
INSTALL 330' - 12" .375w GrB FBE STL  
VCU: ML REPL-L#1157-HP-OH15369

**CORROSION NOTE:** ALL ANODES INSTALLED SHOULD BE NO MORE THAN 500' APART AND TEST BOXES INSTALLED NO MORE THAN 1000'. TEST POINTS INSTALLED ALONG THE MAINLINE SHALL BE LOCATED TO THE EDGE OF THE EASEMENTS, FENCE LINES, OR TREE LINES TO AVOID PEDESTAL IN THE MIDDLE OF THE FIELD.

**LEGEND:**

- FEMA 1% ANNUAL CHANCE FLOOD HAZARD
- FEMA REGULATORY FLOODWAY

NOTE: ALL DISTURBANCES WITHIN THE FLOOD PLAIN MUST BE RETURNED TO PRECONSTRUCTION CONTOURS.

NORTH

DRAWING SCALE  
0 20' 40'

REV	DESCRIPTION	DATE	BY

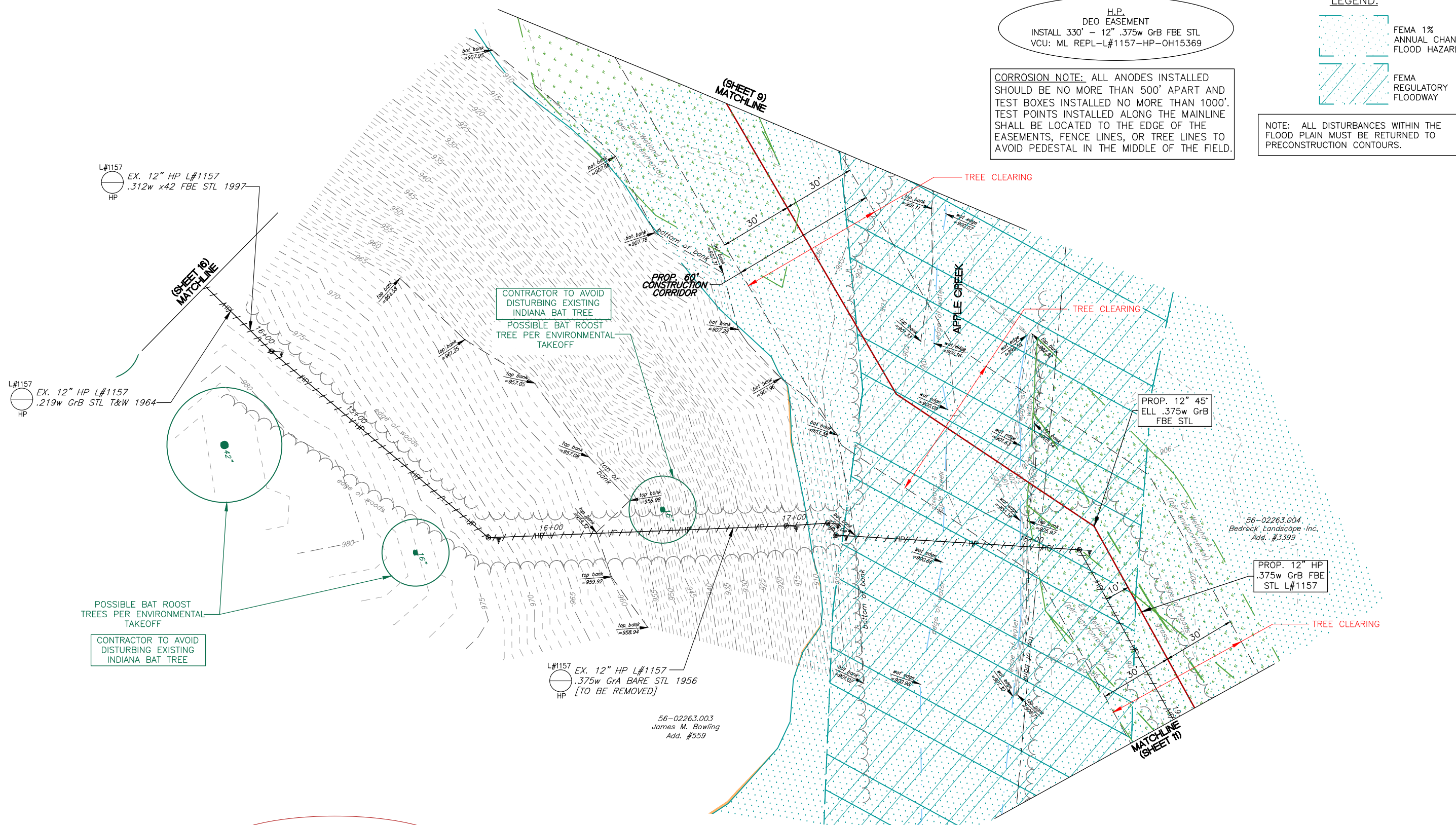
**Dominion Energy**

**PIR 2788 APPLE CREEK  
WOOSTER TWP., WAYNE CNTY**

**DEO EASEMENT**

DATE: 2/19/2024  
PROJECT ID #: **P400243860**

**10**  
**16**



L#1157  
EX. 12" HP L#1157  
.312w x42 FBE STL 1997

L#1157  
EX. 12" HP L#1157  
.219w GrB STL T&W 1964

POSSIBLE BAT ROOST TREES PER ENVIRONMENTAL TAKEOFF

CONTRACTOR TO AVOID DISTURBING EXISTING INDIANA BAT TREE

L#1157  
EX. 12" HP L#1157  
.375w GrA BARE STL 1956  
[TO BE REMOVED]

56-02263.003  
James M. Bowling  
Add. #559

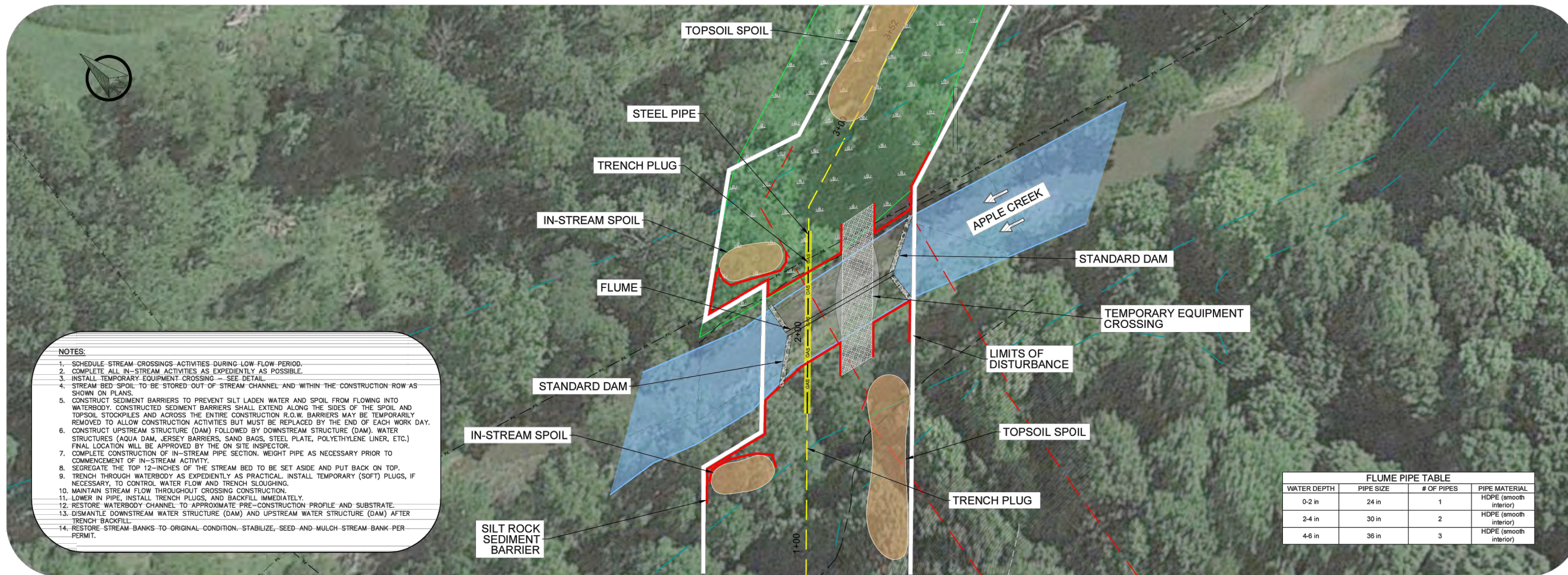
56-02263.004  
Bedrock Landscape Inc.  
Add. #3399

H.P. ABANDONMENT  
DEO EASEMENT  
ABANDON 395' ~ X42 FBE STL  
VCU: ML-RETIRE-L#1157-HP-OH15369

NOTE: CONTRACTOR MUST FOLLOW BEST PRACTICE REGARDING SAFE EMBEDMENT DISTANCE & JOINT REINFORCEMENT OF COMPRESSION COUPLINGS PER D&C MANUAL

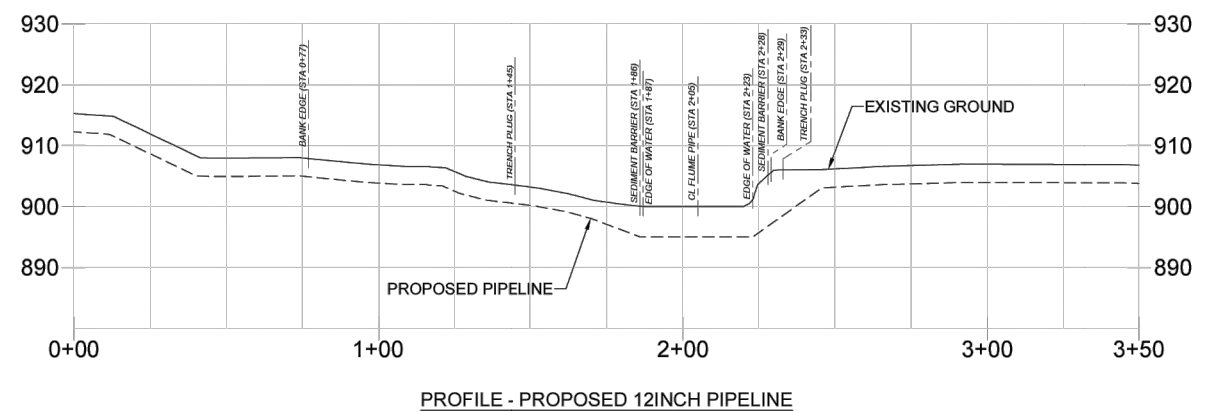


THE OWNER DOES NOT WARRANT THE ACCURACY, SUFFICIENCY, OR COMPLETENESS OF THIS DRAWING OR MAP FOR ANY PURPOSE, AND RELIANCE HEREON AND USE HEREOF IS AT THE RISK OF THE USER, WHO AGREES TO HOLD HARMLESS AND INDEMNIFY THE OWNER AGAINST ANY AND ALL LIABILITY IN CONNECTION WITH ITS USE.



- NOTES:**
- SCHEDULE STREAM CROSSINGS ACTIVITIES DURING LOW FLOW PERIOD.
  - COMPLETE ALL IN-STREAM ACTIVITIES AS EXPEDITIOUSLY AS POSSIBLE.
  - INSTALL TEMPORARY EQUIPMENT CROSSING - SEE DETAIL.
  - STREAM BED SPOIL TO BE STORED OUT OF STREAM CHANNEL AND WITHIN THE CONSTRUCTION ROW AS SHOWN ON PLANS.
  - CONSTRUCT SEDIMENT BARRIERS TO PREVENT SILT LADEN WATER AND SPOIL FROM FLOWING INTO WATERBODY. CONSTRUCTED SEDIMENT BARRIERS SHALL EXTEND ALONG THE SIDES OF THE SPOIL AND TOPSOIL STOCKPILES AND ACROSS THE ENTIRE CONSTRUCTION R.O.W. BARRIERS MAY BE TEMPORARILY REMOVED TO ALLOW CONSTRUCTION ACTIVITIES BUT MUST BE REPLACED BY THE END OF EACH WORK DAY.
  - CONSTRUCT UPSTREAM STRUCTURE (DAM) FOLLOWED BY DOWNSTREAM STRUCTURE (DAM), WATER STRUCTURES (AQUA DAM, JERSEY BARRIERS, SAND BAGS, STEEL PLATE, POLYETHYLENE LINER, ETC.) FINAL LOCATION WILL BE APPROVED BY THE ON SITE INSPECTOR.
  - COMPLETE CONSTRUCTION OF IN-STREAM PIPE SECTION. WEIGHT PIPE AS NECESSARY PRIOR TO COMMENCEMENT OF IN-STREAM ACTIVITY.
  - SEGREGATE THE TOP 12-INCHES OF THE STREAM BED TO BE SET ASIDE AND PUT BACK ON TOP.
  - TRENCH THROUGH WATERBODY AS EXPEDITIOUSLY AS PRACTICAL. INSTALL TEMPORARY (SOFT) PLUGS, IF NECESSARY, TO CONTROL WATER FLOW AND TRENCH SLOUGHING.
  - MAINTAIN STREAM FLOW THROUGHOUT CROSSING CONSTRUCTION.
  - LOWER IN PIPE, INSTALL TRENCH PLUGS, AND BACKFILL IMMEDIATELY.
  - RESTORE WATERBODY CHANNEL TO APPROXIMATE PRE-CONSTRUCTION PROFILE AND SUBSTRATE.
  - DISMANTLE DOWNSTREAM WATER STRUCTURE (DAM) AND UPSTREAM WATER STRUCTURE (DAM) AFTER TRENCH BACKFILL.
  - RESTORE STREAM BANKS TO ORIGINAL CONDITION. STABILIZE, SEED AND MULCH STREAM BANK PER PERMIT.

FLUME PIPE TABLE			
WATER DEPTH	PIPE SIZE	# OF PIPES	PIPE MATERIAL
0-2 in	24 in	1	HDPE (smooth interior)
2-4 in	30 in	2	HDPE (smooth interior)
4-6 in	36 in	3	HDPE (smooth interior)



**LEGEND**

- PROPOSED NATURAL GAS (DIO)
- PROPOSED NATURAL GAS (DIO)
- EXISTING DOMINION BASEMENT
- CONTOUR LINES
- SEDIMENT BARRIER
- LIMITS OF DISTURBANCE
- PROPERTY LINE
- TREE LINE
- DAM
- WETLANDS
- WATERBODY
- SPOIL PILE

UTILITY CROSSING STATION	
R.O.W. AND PROPERTY LINE STATIONS	

SUMMARY OF MATERIALS		
ITEM#	QUANTITY	DESCRIPTION
①	87' LF	12" STEEL, 0.375 W.T., X52, FBE H.P. L#1033

**NOTES**

- BASE DRAWING IS DERIVED FROM EXISTING MAP AND DRAWING INFORMATION AS INDICATED IN THE REFERENCE SECTION. THE ACCURACY OF THE INFORMATION IS NOT GUARANTEED. CONTRACTOR SHALL VERIFY CONDITIONS AND UTILITY LOCATIONS PRIOR TO CONSTRUCTION.

**REVISIONS**

REV.	DESIGN	DRAFT	CHECK	DATE	DESCRIPTION
0	DTW	MLF	WPS	03/07/22	INITIAL SUBMITTAL.
1	DTW	MLF	WPS	02/16/23	REVISED PER CLIENTS COMMENTS.

**REFERENCE SECTION**

- SURVEY PROVIDED BY DOMINION ENERGY.

**TEST DATA**

TESTED FROM STATION: \_\_\_\_\_ TO STATION: \_\_\_\_\_  
 MEDIUM: \_\_\_\_\_ RECORD TEST PRESSURE: \_\_\_\_\_ psig

**PROJECT**

**PIR-2788 / APPLE CREEK  
OPEN-CUT DRY-DITCH  
WOOSTER TWP., WAYNE CNTY, OH**

**ALIGNMENT SHEET**

SCALE  
 PLAN 1" = 30'  
 PROFILE 1" = 30'  
 VERT. 1" = 15'

**RK&K**  
 CONSULTING ENGINEERS  
 124 FLOYD SMITH OFFICE  
 PARK DRIVE, SUITE 240  
 CHARLOTTE, NC 28202  
 LICENSE # C04.00608  
 PHONE: 980-235-0011

RK&K COM. NO. 20035.802.002



**PIR 2788 APPLE CREEK  
WOOSTER TWP., WAYNE CNTY**

**APPLE CREEK  
PROFILE**

DATE: 2/19/2024  
 PROJECT ID #: P400243860

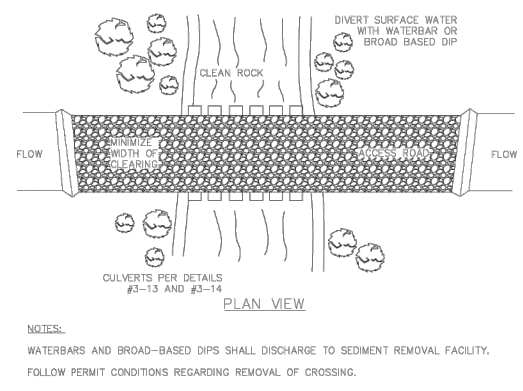
DRAWING: DEO-PIR2788-001  
 SHEET DESCRIPTION: PLAN & PROFILE SHEET PIR-2788 / APPLE CREEK  
 REVISION: 1

SCALE: DRAWING SCALE  
 NO TO SCALE

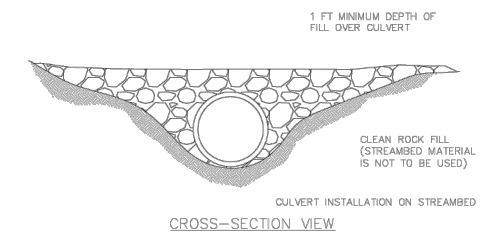
10A  
 16



THE OWNER DOES NOT WARRANT THE ACCURACY, SUFFICIENCY, OR COMPLETENESS OF THIS DRAWING OR MAP FOR ANY PURPOSE, AND RELIANCE HEREON AND USE HEREOF IS AT THE RISK OF THE USER, WHO AGREES TO HOLD HARMLESS AND INDEMNIFY THE OWNER AGAINST ANY AND ALL LIABILITY IN CONNECTION WITH ITS USE.



**STANDARD CONSTRUCTION DETAIL #3-12**  
**TEMPORARY STREAM CROSSING - PLAN VIEW**  
 NOT TO SCALE

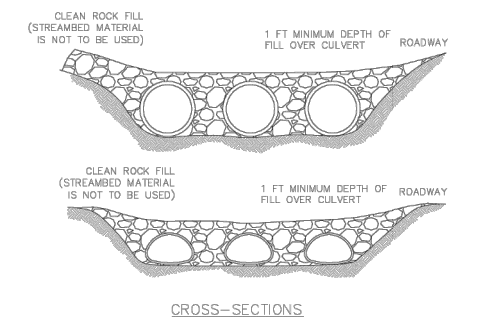


**NOTES:**  
 PROVIDE 50' STABILIZED ACCESS TO CROSSING ON BOTH SIDES OF STREAM CHANNEL (SEE STANDARD CONSTRUCTION DETAIL #3-12).  
 PIPES SHALL EXTEND BEYOND THE TOE OF THE ROADWAY.  
 RUNOFF FROM THE ROADWAY SHALL BE DIVERTED OFF THE ROADWAY AND INTO A SEDIMENT REMOVAL BMP BEFORE IT REACHES THE ROCK APPROACH TO THE CROSSING.

**MAINTENANCE:**  
 1. TEMPORARY STREAM CROSSINGS SHALL BE INSPECTED ON A DAILY BASIS.  
 2. DAMAGED CROSSINGS SHALL BE REPAIRED WITHIN 24 HOURS OF THE INSPECTION AND BEFORE ANY SUBSEQUENT USE.  
 3. SEDIMENT DEPOSITS ON THE CROSSING OR ITS APPROACHES SHALL BE REMOVED WITHIN 24 HOURS OF THE INSPECTION.

AS SOON AS THE TEMPORARY CROSSING IS NO LONGER NEEDED, IT SHALL BE REMOVED. ALL MATERIALS SHALL BE DISPOSED OF PROPERLY AND DISTURBED AREAS STABILIZED.

**STANDARD CONSTRUCTION DETAIL #3-13**  
**TEMPORARY STREAM CROSSING**  
 NOT TO SCALE

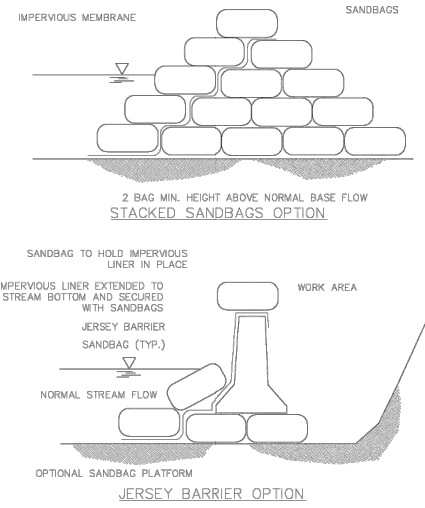


**NOTES:**  
 PROVIDE 50' STABILIZED ACCESS TO CROSSING ON BOTH SIDES OF STREAM CHANNEL (SEE STANDARD CONSTRUCTION DETAIL #3-12).  
 PIPES SHALL EXTEND BEYOND THE TOE OF THE ROADWAY.  
 RUNOFF FROM THE ROADWAY SHALL BE DIVERTED OFF THE ROADWAY AND INTO A SEDIMENT REMOVAL BMP BEFORE IT REACHES THE ROCK APPROACH TO THE CROSSING.

**MAINTENANCE:**  
 1. TEMPORARY STREAM CROSSINGS SHALL BE INSPECTED ON A DAILY BASIS.  
 2. DAMAGED CROSSINGS SHALL BE REPAIRED WITHIN 24 HOURS OF THE INSPECTION AND BEFORE ANY SUBSEQUENT USE.  
 3. SEDIMENT DEPOSITS ON THE CROSSING OR ITS APPROACHES SHALL BE REMOVED WITHIN 24 HOURS OF THE INSPECTION.

AS SOON AS THE TEMPORARY CROSSING IS NO LONGER NEEDED, IT SHALL BE REMOVED. ALL MATERIALS SHALL BE DISPOSED OF PROPERLY AND DISTURBED AREAS STABILIZED.

**STANDARD CONSTRUCTION DETAIL #3-14**  
**TEMPORARY STREAM CROSSING - MULTIPLE PIPES**  
 NOT TO SCALE

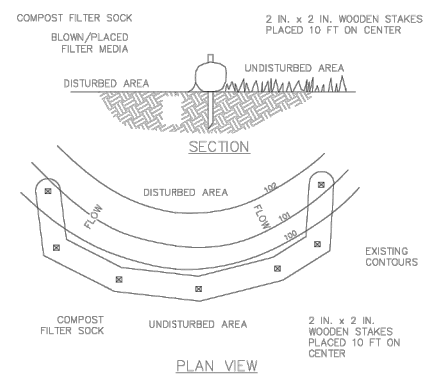


**STANDARD CONSTRUCTION DETAIL #3-15**  
**SANDBAG DIVERSION DAM OR COFFERDAM**  
 NOT TO SCALE

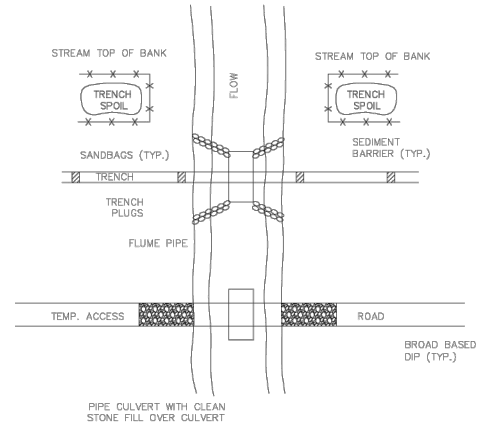
TABLE 6.6.1 MAXIMUM SLOPE LENGTH ABOVE FILTER SOCK AND RECOMMENDED DIAMETER

SLOPE	RATIO (H:V)	8"	12"	18"	24"
0% - 2%	10% - 20%	125	250	300	350
10% - 20%	50:1 - 10:1	100	125	200	250
2% - 10%	10:1 - 5:1	75	100	150	200
20% - 33%	5:1 - 2:1		50	75	100
>50%	>2:1		25	50	75

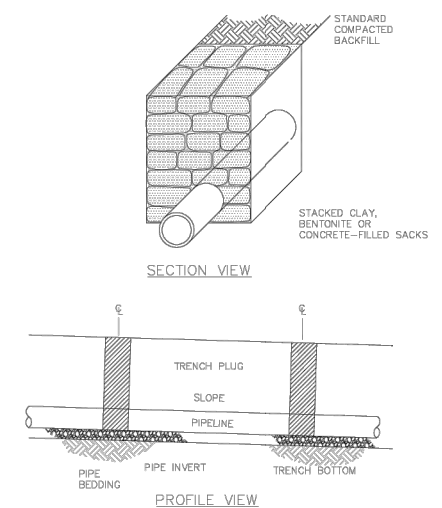
NOTE: FOR LARGER DRAINAGE AREAS, SEE STANDARDS FOR TEMPORARY DIVERSIONS, SEDIMENT TRAPS AND SEDIMENT BASINS.



**STANDARD CONSTRUCTION DETAIL #4-1**  
**COMPOST FILTER SOCK**  
 NOT TO SCALE



**STANDARD CONSTRUCTION DETAIL #13-1**  
**TYPICAL UTILITY LINE STREAM CROSSING WITH OPTIONAL ACCESS ROAD**  
 NOT TO SCALE



**TRENCH BREAKER (ALSO KNOW AS TRENCH PLUGS) SPACING (ADAPTED FROM THE PENNSYLVANIA STATE STANDARDS)**

SLOPE (%)	SPACING (FEET)
0-5	NOT REQUIRED EXCEPT AT STREAM OR WATER BODY CROSSINGS
5 - 15	300
>15 - 30	200
>30	100

**NOTES:**  
 1. TRENCH BREAKERS ARE REQUIRED UPSLOPE OF ALL STREAM, RIVER, OR WATER-BODY CROSSINGS REGARDLESS OF TRENCH SLOPE.  
 2. DEPENDING ON THE SPECIFIC CONDITIONS OF SLOPES EXCEEDING 40%, THE SPACING BETWEEN TRENCH BREAKERS MAY CONTINUE DIMINISHING AS ILLUSTRATED, OR MAY CEASE ONCE A SPACING OF 33 FEET HAS BEEN REACHED.  
 3. TRENCH BREAKERS SHALL BE SAND BAGS OR EARTH FILLED SACKS (NOT TOPSOIL), WHICH ARE DURABLE YET FLEXIBLE AND WILL CONFORM TO GRADUAL SHIFTING OF PIPELINE AND BACKFILL, WHILE SERVING THEIR FUNCTION, TO IMPEDE THE FLOW OF SUBSURFACE WATER ALONG THE TRENCH. ALTERNATIVELY, CEMENT FILLED BAGS OR MORTARED STONE MAY BE USED.  
 4. IN AGRICULTURAL LANDS, THE TOP OF TRENCH BREAKER WILL NOT BE CLOSER THAN TWO FEET FROM THE RESTORED SURFACE.

**STANDARD CONSTRUCTION DETAIL #13-4**  
**TRENCH PLUG INSTALLATION**  
 NOT TO SCALE

REVISION SECTION			
DATE	REV.	DESCRIPTION	BY
03/07/22	0	ISSUED FOR REVIEW.	RKK
02/16/23	1	REVISED PER CLIENT COMMENTS.	RKK

CONSULTING ENGINEERS  
 124 FURDO SMITH OFFICE  
 PARK DRIVE, SUITE 240  
 CHARLOTTE, NC 28262  
 LICENSE # CAD.000508  
 PHONE: 980-235-0011

DESIGNED BY: DTW  
 DRAWN BY: MLF  
 CHECKED BY: WPS

SCALE: NTS

RK&K COM. NO. 20035.802.002



DRAWING SCALE  
 NOT TO SCALE



PIR 2788 APPLE CREEK  
 WOOSTER TWP., WAYNE CNTY



EROSION & SEDIMENTATION  
 CONTROL DETAILS

DRAWING: DEO-PIR2788-D001  
 REVISION: 1  
 DATE: 2/19/2024  
 PROJECT ID #: P400243860

10B  
 16



THE OWNER DOES NOT WARRANT THE ACCURACY, SUFFICIENCY, OR COMPLETENESS OF THIS DRAWING OR MAP FOR ANY PURPOSE, AND RELIANCE HEREON AND USE HEREOF IS AT THE RISK OF THE USER, WHO AGREES TO HOLD HARMLESS AND INDEMNIFY THE OWNER AGAINST ANY AND ALL LIABILITY IN CONNECTION WITH ITS USE.

H.P.  
DEO EASEMENT  
INSTALL 445' - 12" .375w GrB FBE STL  
VCU: ML REPL-L#1157-HP-OH15369

CORROSION NOTE: ALL ANODES INSTALLED SHOULD BE NO MORE THAN 500' APART AND TEST BOXES INSTALLED NO MORE THAN 1000'. TEST POINTS INSTALLED ALONG THE MAINLINE SHALL BE LOCATED TO THE EDGE OF THE EASEMENTS, FENCE LINES, OR TREE LINES TO AVOID PEDESTAL IN THE MIDDLE OF THE FIELD.

**LEGEND:**

FEMA 1% ANNUAL CHANCE FLOOD HAZARD  
FEMA REGULATORY FLOODWAY

NOTE: ALL DISTURBANCES WITHIN THE FLOOD PLAIN MUST BE RETURNED TO PRECONSTRUCTION CONTOURS.

**NORTH**

DRAWING SCALE

REV	DESCRIPTION	DATE	BY



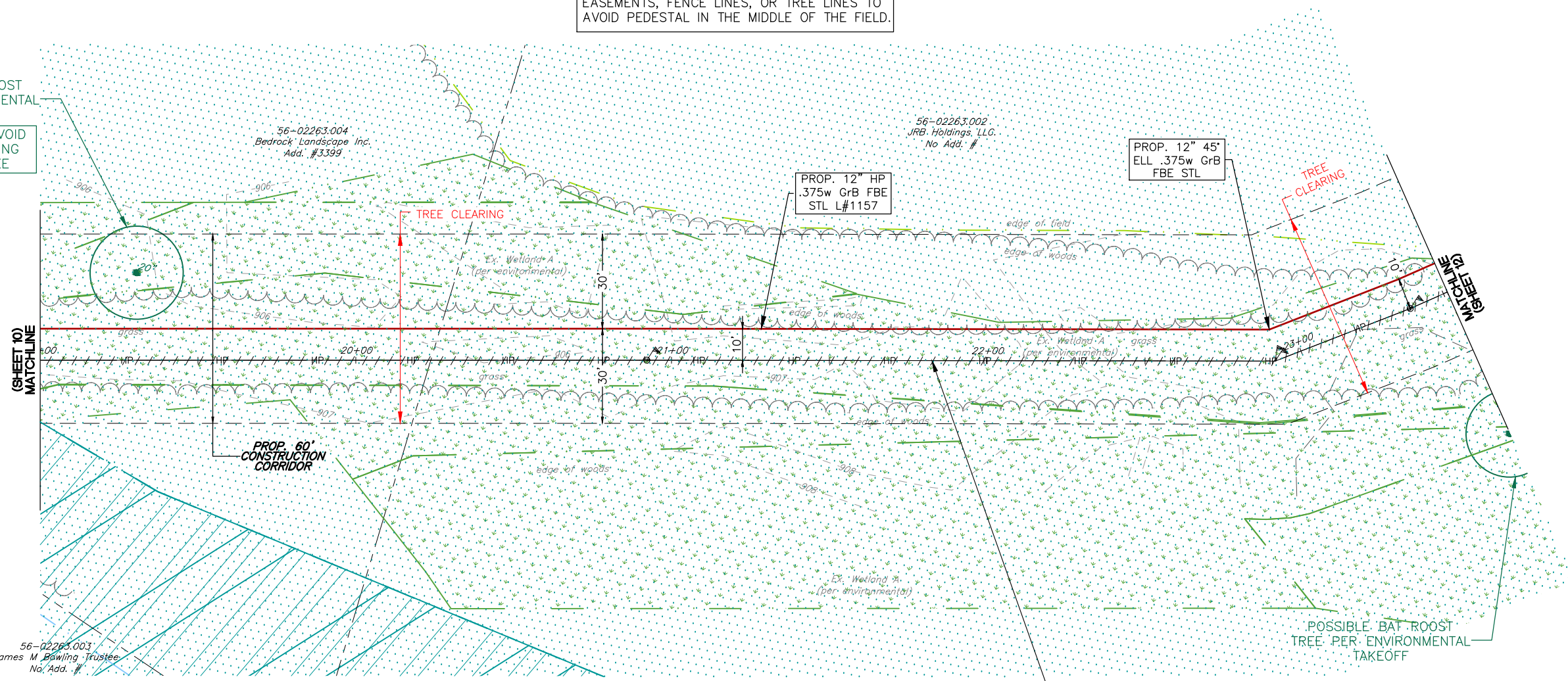
PIR 2788 APPLE CREEK  
WOOSTER TWP., WAYNE CNTY

DEO EASEMENT

DATE: 2/19/2024  
PROJECT ID #: P400243860

11  
16

POSSIBLE BAT ROOST TREE PER ENVIRONMENTAL TAKEOFF  
CONTRACTOR TO AVOID DISTURBING EXISTING INDIANA BAT TREE



56-02263.003  
James M Bowling Trustee  
No. Add. #

56-02263.004  
Bedrock Landscape Inc.  
Add. #3399

56-02263.002  
JRB Holdings, LLC.  
No Add. #

PROP. 12" HP  
.375w GrB FBE  
STL L#1157

PROP. 12" 45"  
ELL .375w GrB  
FBE STL

PROP. 60'  
CONSTRUCTION  
CORRIDOR

EX. 12" HP L#1157  
.375w GrA BARE STL 1956  
[TO BE REMOVED]





NOTE: CONTRACTOR MUST FOLLOW BEST PRACTICE REGARDING SAFE EMBEDMENT DISTANCE & JOINT REINFORCEMENT OF COMPRESSION COUPLINGS PER D&C MANUAL

THE OWNER DOES NOT WARRANT THE ACCURACY, SUFFICIENCY, OR COMPLETENESS OF THIS DRAWING OR MAP FOR ANY PURPOSE, AND RELIANCE HEREON AND USE HEREOF IS AT THE RISK OF THE USER, WHO AGREES TO HOLD HARMLESS AND INDEMNIFY THE OWNER AGAINST ANY AND ALL LIABILITY IN CONNECTION WITH ITS USE.

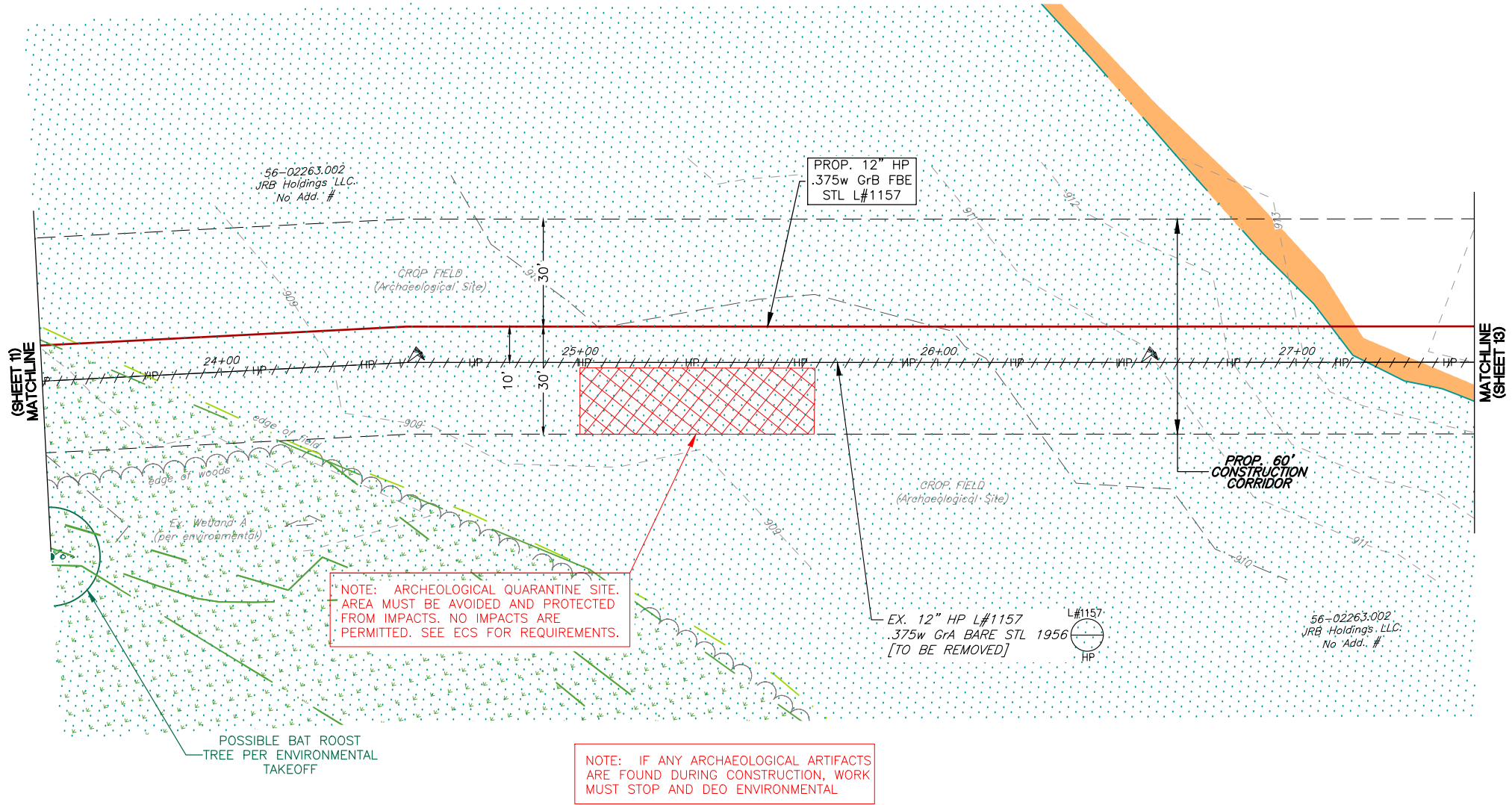
H.P.  
DEO EASEMENT  
INSTALL 400' - 12" .375w GrB FBE STL  
VCU: ML REPL-L#1157-HP-OH15369


**CORROSION NOTE:** ALL ANODES INSTALLED SHOULD BE NO MORE THAN 500' APART AND TEST BOXES INSTALLED NO MORE THAN 1000'. TEST POINTS INSTALLED ALONG THE MAINLINE SHALL BE LOCATED TO THE EDGE OF THE EASEMENTS, FENCE LINES, OR TREE LINES TO AVOID PEDESTAL IN THE MIDDLE OF THE FIELD.

**LEGEND:**

-  FEMA 1% ANNUAL CHANCE FLOOD HAZARD
-  FEMA .2% ANNUAL CHANCE FLOOD HAZARD

NOTE: ALL DISTURBANCES WITHIN THE FLOOD PLAIN MUST BE RETURNED TO PRECONSTRUCTION CONTOURS.



 NORTH

DRAWING SCALE

0 20' 40'

REV	DESCRIPTION	DATE	BY



PIR 2788 APPLE CREEK  
WOOSTER TWP., WAYNE CNTY

DEO EASEMENT

DATE: 2/19/2024  
PROJECT ID #: P400243860

12  
16

NOTE: CONTRACTOR MUST FOLLOW BEST PRACTICE REGARDING SAFE EMBEDMENT DISTANCE & JOINT REINFORCEMENT OF COMPRESSION COUPLINGS PER D&C MANUAL

THE OWNER DOES NOT WARRANT THE ACCURACY, SUFFICIENCY, OR COMPLETENESS OF THIS DRAWING OR MAP FOR ANY PURPOSE, AND RELIANCE HEREON AND USE HEREOF IS AT THE RISK OF THE USER, WHO AGREES TO HOLD HARMLESS AND INDEMNIFY THE OWNER AGAINST ANY AND ALL LIABILITY IN CONNECTION WITH ITS USE.

H.P.  
DEO ESEMENT  
INSTALL 55' - 12" .375w GrB FBE STL  
VCU: ML REPL-L#1157-HP-OH15369

CORROSION NOTE: ALL ANODES INSTALLED SHOULD BE NO MORE THAN 500' APART AND TEST BOXES INSTALLED NO MORE THAN 1000'. TEST POINTS INSTALLED ALONG THE MAINLINE SHALL BE LOCATED TO THE EDGE OF THE EASEMENTS, FENCE LINES, OR TREE LINES TO AVOID PEDESTAL IN THE MIDDLE OF THE FIELD.

CAUTION: ALL EXCAVATIONS WITHIN 100' OF M&R STATION REQUIRE FIELD VERIFICATION OF CRITICAL COMPONENT LOCATIONS (SENSING LINES, SLAM SHUTS, ISOLATION VALVES ETC.). DEO GM&R MUST BE ONSITE PRIOR TO ANY EXCAVATION WITHIN DEFINED BOUNDARY.  
SEE COVER SHEET FOR APPROVAL SIGNATURES.  
\* ANY CHANGES TO DRAWINGS WITHIN STATION BOUNDARY REQUIRE NEW SIGNATURES

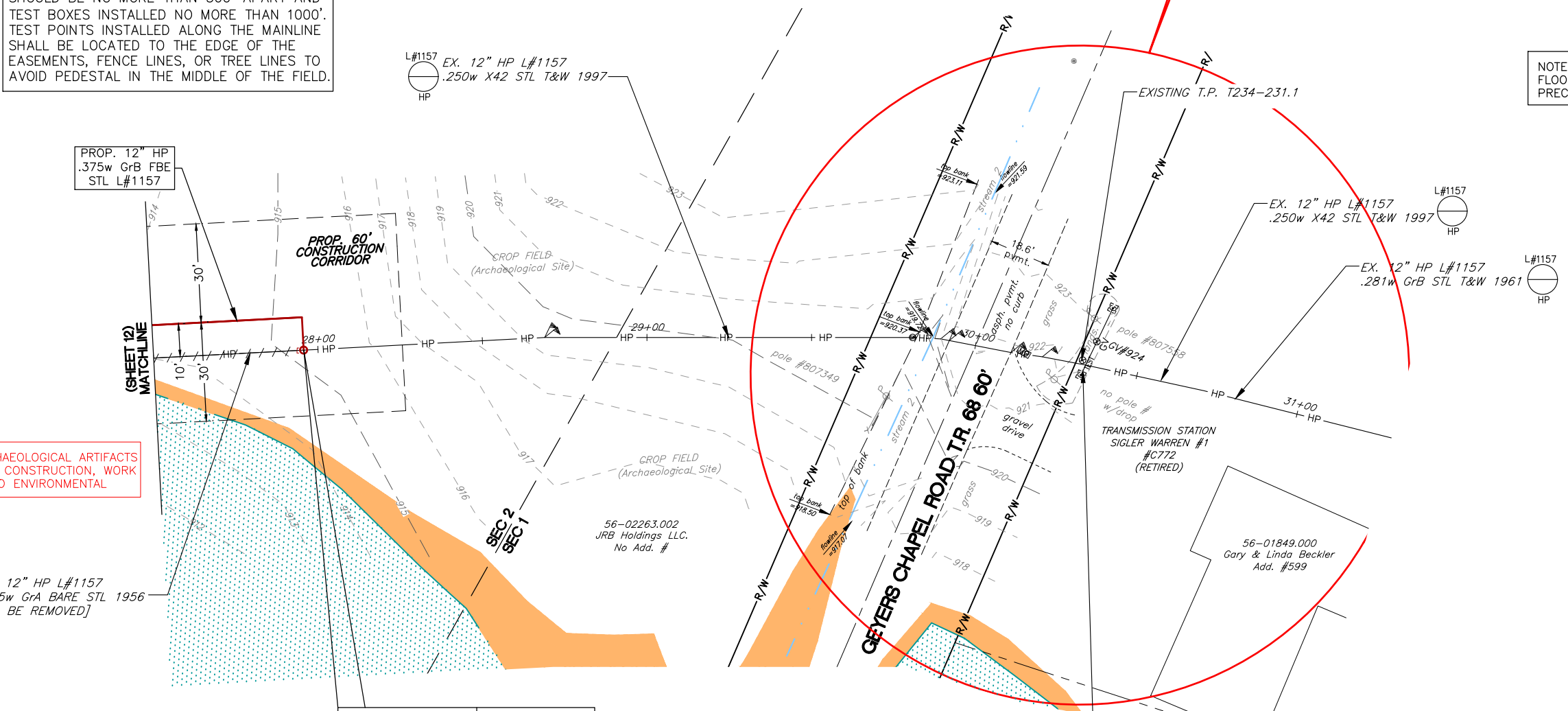
LEGEND:  
[Dotted pattern] FEMA 1% ANNUAL CHANCE FLOOD HAZARD  
[Orange fill] FEMA .2% ANNUAL CHANCE FLOOD HAZARD

NOTE: ALL DISTURBANCES WITHIN THE FLOOD PLAIN MUST BE RETURNED TO PRECONSTRUCTION CONTOURS.

NOTE: IF ANY ARCHAEOLOGICAL ARTIFACTS ARE FOUND DURING CONSTRUCTION, WORK MUST STOP AND DEO ENVIRONMENTAL

L#1157 EX. 12" HP L#1157  
.375w GrA BARE STL 1956  
[TO BE REMOVED]

GAS FEED @ TIE-IN:  
SINGLE  
GAS FLOW DISCLAIMER - SEE GENERAL NOTES PAGE  
HP L#1157 TIE-IN  
CONTRACTOR TO INSTALL 12" 300 ANSI 3-WAY SPHERICAL TEE & PURGE FITTINGS & TIE COMPLETE W/  
(1) 12" 90° ELL .375w GrB  
(2) 12" 300 ANSI FLANGES  
(1) 12" 150 ANSI INSULATION KIT CAP W/ (2) 300 ANSI WELD NECK FLANGES AND (2) 300 ANSI BLIND FLANGES  
185'SW PERMANENT MARKER OFF GEYERS CHAPEL ROAD.  
FB NA STA. NA  
INSTALL TEST BOX & 17# ANODE, RETAIL T234-229.1



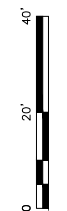
NORTH  
DRAWING SCALE: 0 20' 40'  
DATE: 2/19/2024  
PROJECT ID #: P400243860  
PIR 2788 APPLE CREEK WOOSTER TWP., WAYNE CNTY  
DEO EASEMENT  
13  
16



THE OWNER DOES NOT WARRANT THE ACCURACY, SUFFICIENCY, OR COMPLETENESS OF THIS DRAWING OR MAP FOR ANY PURPOSE, AND RELIANCE HEREON AND USE HEREOF IS AT THE RISK OF THE USER, WHO AGREES TO HOLD HARMLESS AND INDEMNIFY THE OWNER AGAINST ANY AND ALL LIABILITY IN CONNECTION WITH ITS USE.



NORTH



DRAWING SCALE

REV	DESCRIPTION	DATE	BY



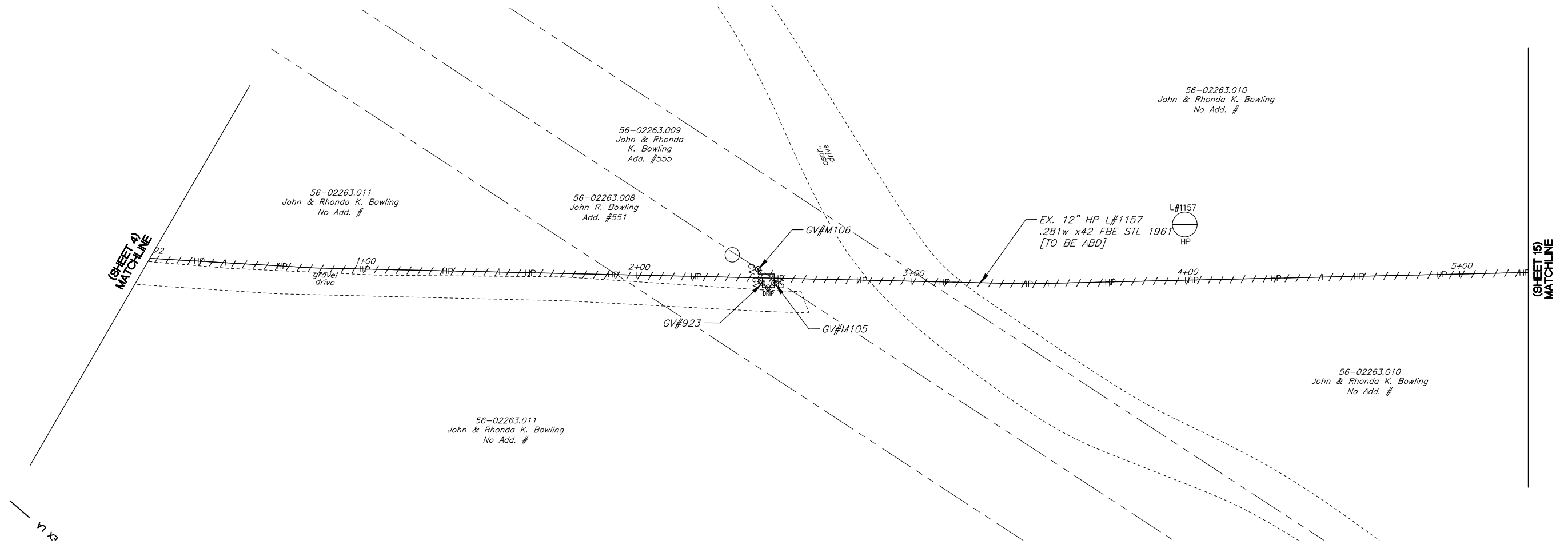
PIR 2788 APPLE CREEK  
WOOSTER TWP., WAYNE CNTY

DEO EASEMENT

DATE: 2/19/2024  
PROJECT ID #: P400243860

14  
16

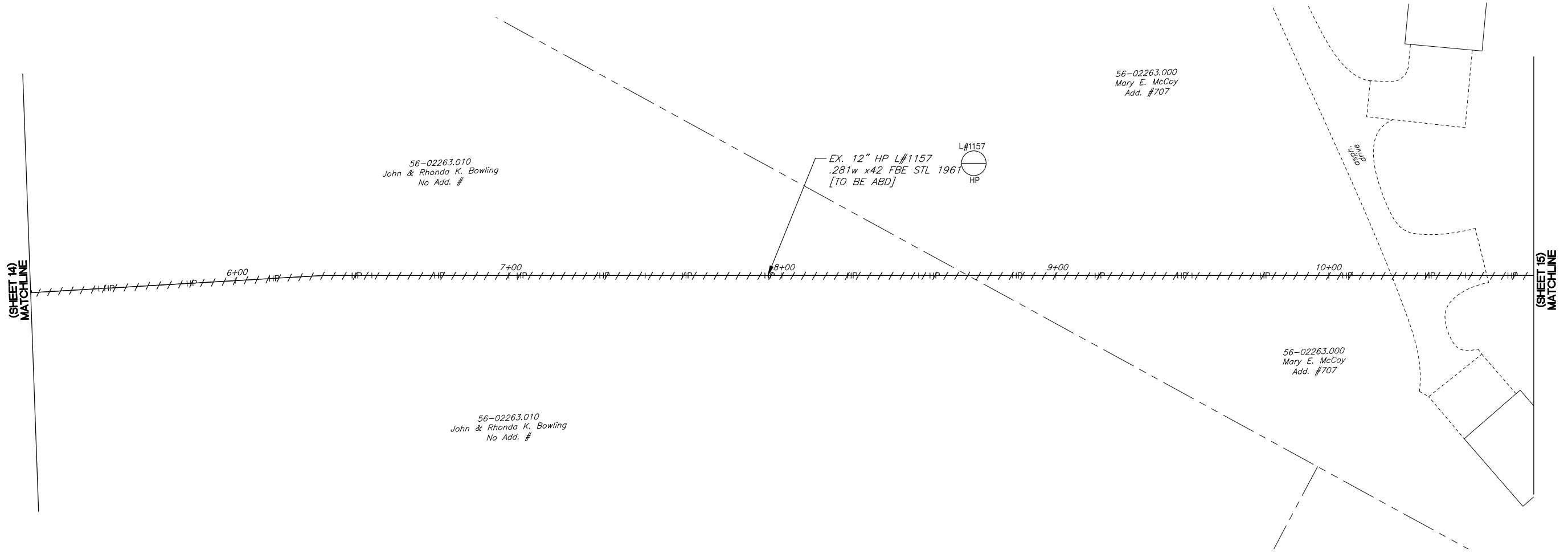
H.P. ABANDONMENT  
DEO EASEMENT  
ABANDON 506' ~ X42 FBE STL  
VCU: ML-RETIRE-L#1157-HP-OH15369



NOTE: DRIP TO BE ABANDONED  
ON SHEET 14 TO BE PUMPED  
CLEAN AND ALL ABOVE GROUND  
APPERTUERS TO BE REMOVED.

NOTE: REMOVE VALVE BOXES AND FILL IN  
ALONG THE ABANDONED LINE. REMOVE  
PIPELINE MARKERS ALONG THE ABANDONED  
LINE.

THE OWNER DOES NOT WARRANT THE ACCURACY, SUFFICIENCY, OR COMPLETENESS OF THIS DRAWING OR MAP FOR ANY PURPOSE, AND RELIANCE HEREON AND USE HEREOF IS AT THE RISK OF THE USER, WHO AGREES TO HOLD HARMLESS AND INDEMNIFY THE OWNER AGAINST ANY AND ALL LIABILITY IN CONNECTION WITH ITS USE.

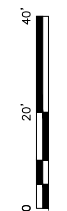


H.P. ABANDONMENT  
 DEO EASEMENT  
 ABANDON 550' ~ X42 FBE STL  
 VCU: ML-RETIRE-L#1157-HP-OH15369

NOTE: REMOVE VALVE BOXES AND FILL IN ALONG THE ABANDONED LINE. REMOVE PIPELINE MARKERS ALONG THE ABANDONED LINE.



NORTH



DRAWING SCALE

REV	DESCRIPTION	DATE	BY



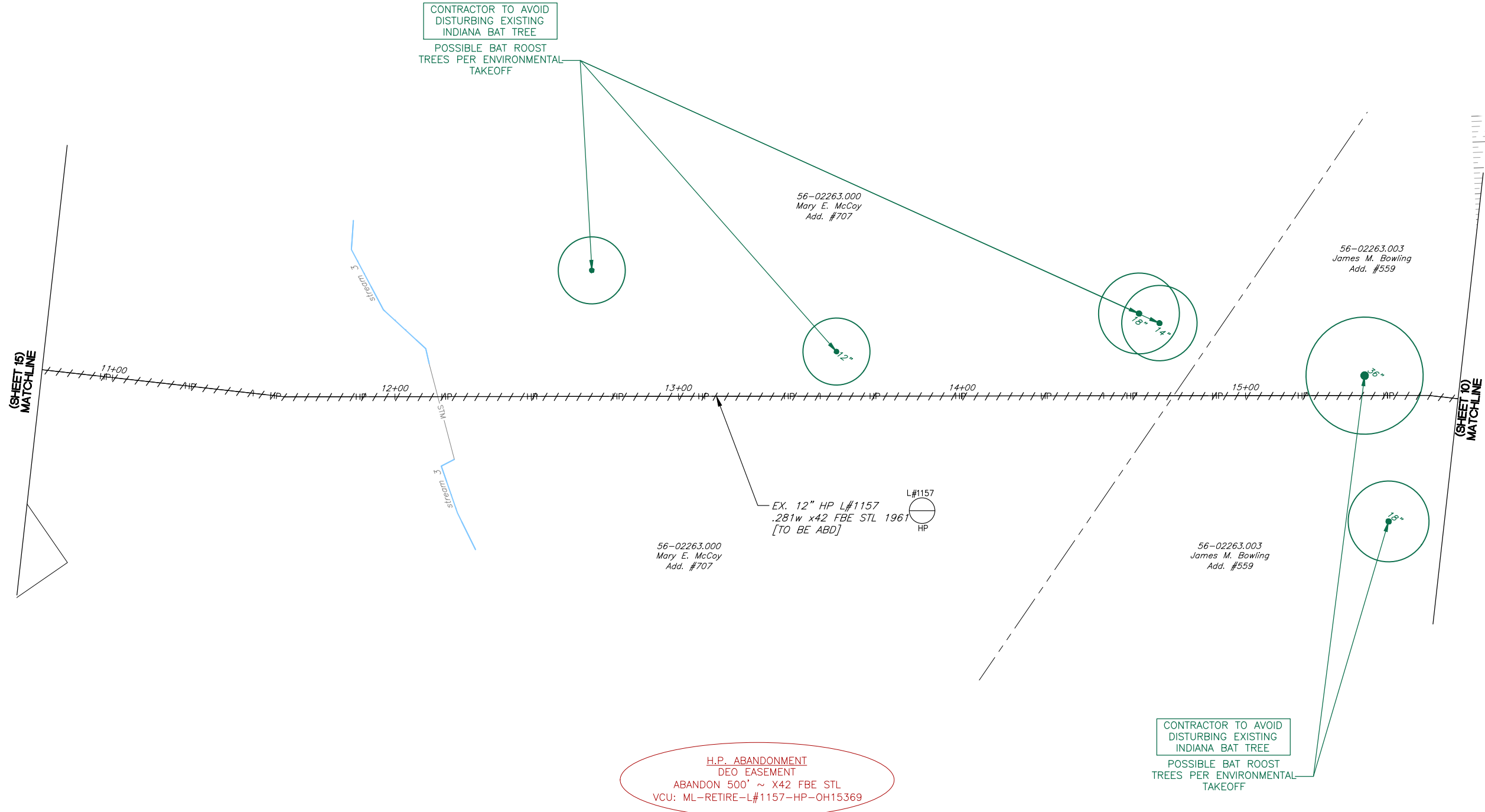
PIR 2788 APPLE CREEK  
 WOOSTER TWP., WAYNE CNTY

DEO EASEMENT

DATE: 2/19/2024  
 PROJECT ID #: P400243860

15  
 16

THE OWNER DOES NOT WARRANT THE ACCURACY, SUFFICIENCY, OR COMPLETENESS OF THIS DRAWING OR MAP FOR ANY PURPOSE, AND RELIANCE HEREON AND USE HEREOF IS AT THE RISK OF THE USER, WHO AGREES TO HOLD HARMLESS AND INDEMNIFY THE OWNER AGAINST ANY AND ALL LIABILITY IN CONNECTION WITH ITS USE.



NORTH



REV	DESCRIPTION	DATE	BY



**PIR 2788 APPLE CREEK  
WOOSTER TWP., WAYNE CNTY**

**DEO EASEMENT**

DATE: 2/19/2024  
PROJECT ID #: **P400243860**

16  
16

NOTE: REMOVE VALVE BOXES AND FILL IN ALONG THE ABANDONED LINE. REMOVE PIPELINE MARKERS ALONG THE ABANDONED LINE.



**Attachment 4**

**Ohio EPA General Permit OHC000006 NOI Documentation**




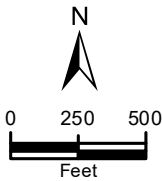
*Please add any additional comments or attachments below.*



Project Name: PIR 2788 – Apple Creek  
Facility Contact: David Hollendonner



 Project Study Area



**Figure 1**  
**Site Location Map**

PIR 2788 - Apple Creek  
Dominion Energy Ohio  
Wayne County, Ohio  
Date: 1/17/2024



**ATTACHMENT H**  
**OHIO ENVIRONMENTAL PROTECTION AGENCY NOI FOR GENERAL**  
**CONSTRUCTION STORMWATER PERMIT APPLICATION**



# Division of Surface Water - Notice of Intent (NOI) For Coverage Under Ohio Environmental Protection Agency General NPDES Permit

(Read accompanying instructions carefully before completing this form.)

Submission of this NOI constitutes notice that the party identified in Section I of this form intends to be authorized to discharge into state surface waters under Ohio EPA's NPDES general permit program. Becoming a permittee obligates a discharger to comply with the terms and conditions of the permit. Complete all required information as indicated by the instructions. Do not use correction fluid on this form. Forms transmitted by fax will not be accepted. A check for the proper amount must accompany this form and be made payable to "Treasurer, State of Ohio." (See the fee table in Attachment C of the NOI instructions for the appropriate processing fee.)

### I. Applicant Information/Mailing Address

**Company (Applicant) Name:** The East Ohio Gas Co d/b/a Dominion Energy Ohio

**Mailing (Applicant) Address:** 320 Springside Drive, Suite 320

**City:** Akron

**State :** OH

**Zip Code:** 44333

**Country:** USA

**Contact Person:** Greg Eastridge

**Phone:** (330) 664-2576

**Fax:** (330) 664-2669

**Contact E-mail Address:** gregory.k.eastridge@dominionenergy.com

### II. Facility/Site Location Information

**Facility/Site Name:** PIR 2788 - Apple Creek

**Facility Address:** North Hillcrest Drive

**City:** Wooster Township

**State:** OH

**Zip Code:** 44691

**County:** Wayne

**Township:** Wooster

**Facility Contact Person:** David Hollendonner

**Phone:** (330) 664-2677

**Fax:** (330) 664-2691

**Facility Contact E-mail Address:** david.hollendonner@dominionenergy.com

**Latitude:** 40.803269

**Longitude:** -81.898264

**Facility/Map Attachment**

PIR2788\_NOI\_SLM\_20240117.pdf

**Receiving Stream or MS4:** Apple Creek, Wayne County MS4 (3GQ00139\*BG)

### III. General Permit Information

**General Permit Number:** OHC000006

**Coverage Type:** New

**Type of Activity:** Construction Site Stormwater General Permit

**SIC Code(s):**

**Existing NPDES Facility Permit Number:** 3GC14872\*AG

**ODNR Coal Mining Application Number:**

**If Household Sewage Treatment System, is system for:**

**New Home Construction:**

**Replacement of failed existing system:**

Outfall	Design Flow (MGD):	Associated Permit Effluent Table:	Receiving Water :	Latitude	Longitude

**Are These Permits Required?**

**PTI:** NO

**Individual 401 Water Quality Certification:** NO

**Individual NPDES:** NO

**Isolated Wetland:** NO

**U.S. Army Corp Nationwide Permit:** PENDING

**Proposed Project Start Date(if applicable):** June 03, 2024

**Estimated Completion Date(if applicable):** December 31, 2024

**Total Land Disturbance (Acres):** 5.4

**MS4 Drainage Area (Sq. Miles):**

**SWP3 Attachment(s):** <None>

### IV. Payment Information

**Check #:**

**For Ohio EPA Use Only**

**Check Amount:**

**Check ID(OFA):** \_\_\_\_\_

**ORG #:** \_\_\_\_\_

**Date of Check:**

**Rev ID:** \_\_\_\_\_

**DOC #:** \_\_\_\_\_

*I certify under penalty of law that this document and all attachments were prepared under my direction or supervision in accordance with a system designed to assure that qualified personnel properly gather and evaluate the information submitted. Based on my inquiry of the person or persons who manage the system, or those persons directly responsible for gathering the information, the information submitted is, to the best of my knowledge and belief, true, accurate and complete. I am aware that there are significant penalties for submitting false information, including the possibility of fine and imprisonment for knowing violations.*

**Applicant Name:** Zachary Goodson

**Title:** Director - Gas Operations

**Signature:**

Electronically submitted by 73189029

**Date:**

Electronically submitted on 02/26/2024

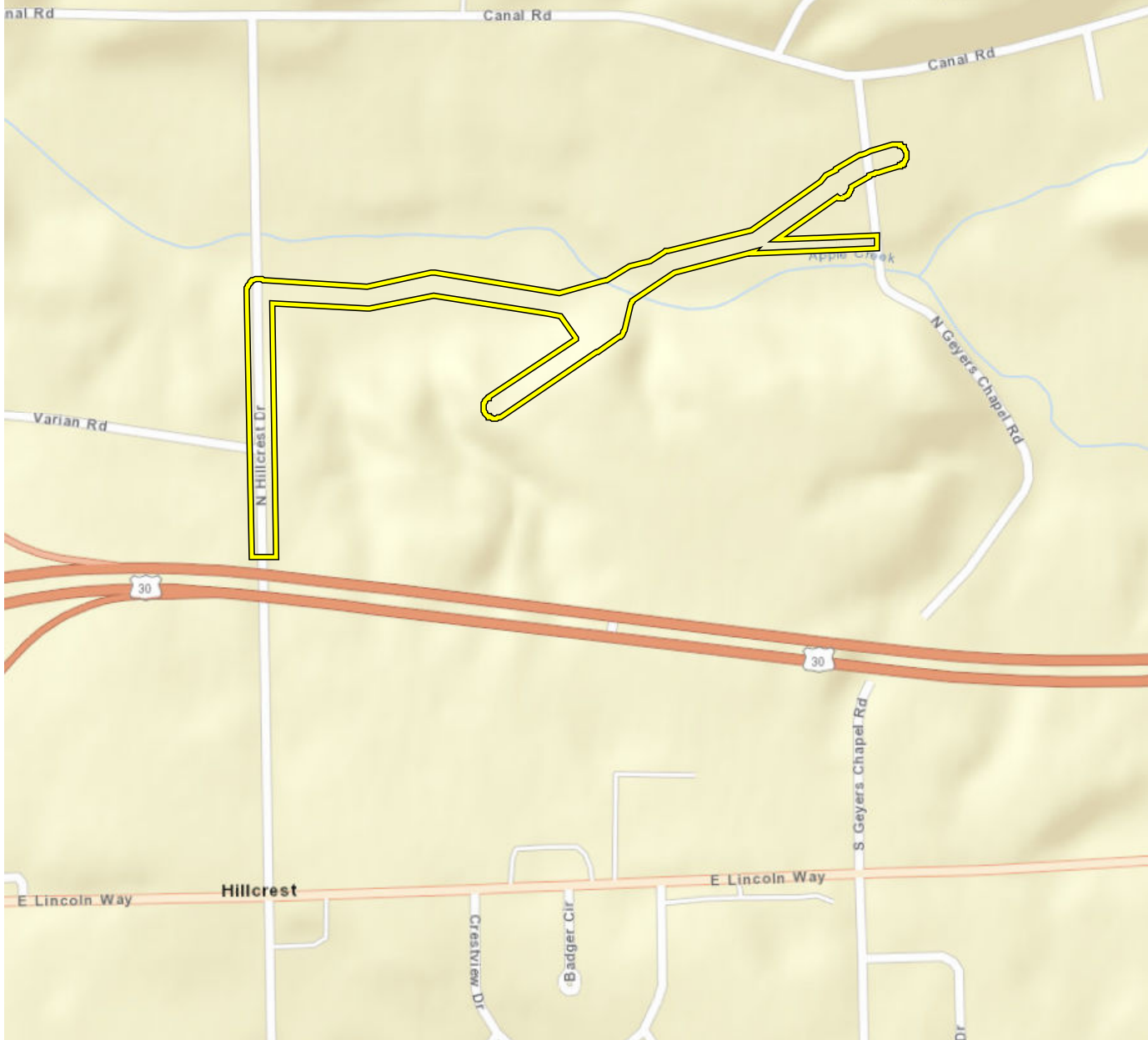
### ADDITIONAL INFORMATION


*Please add any additional comments or attachments below.*

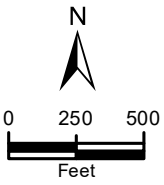




Project Name: PIR 2788 – Apple Creek  
Facility Contact: David Hollendonner



 Project Study Area



**Figure 1  
Site Location Map**

PIR 2788 - Apple Creek  
Dominion Energy Ohio  
Wayne County, Ohio  
Date: 1/17/2024



**ATTACHMENT I**  
**OHIO ENVIRONMENTAL PROTECTION AGENCY ISSUED GENERAL**  
**CONSTRUCTION STORMWATER PERMIT OHC000005**

**Submitted by**  
**The East Ohio Gas Company d/b/a Dominion Energy Ohio**  
Project #P40080793  
13617455v1



## Gregory K Eastridge (Services - 6)

---

**From:** Applegate, Jeromy <jeromy\_applegate@fws.gov>  
**Sent:** Tuesday, January 25, 2022 3:56 PM  
**To:** Gregory K Eastridge (Services - 6)  
**Cc:** Ohio, FW3  
**Subject:** [EXTERNAL] Fw: [EXTERNAL] Bald Eagle Nest Coordination Request, Six Projects In OLS Wooster Township, Wayne County

**CAUTION! This message was NOT SENT from DOMINION ENERGY**

Are you expecting this message to your DE email? Suspicious? Use PhishAlarm to report the message. Open a browser and type in the name of the trusted website instead of clicking on links. DO NOT click links or open attachments until you verify with the sender using a known-good phone number. Never provide your DE password.

Greg,

We do not have any records of a bald eagle nest within 0.5 mile of the projects listed below.

Jeromy Applegate  
Fish and Wildlife Biologist  
U.S. Fish and Wildlife Service  
Ohio Ecological Services Field Office  
4625 Morse Road, Suite 104  
Columbus, Ohio 43230  
Direct Line: 614-528-9703

---

**From:** Ohio, FW3 <ohio@fws.gov>  
**Sent:** Wednesday, January 12, 2022 11:14 AM  
**To:** Applegate, Jeromy <jeromy\_applegate@fws.gov>  
**Subject:** Fw: [EXTERNAL] Bald Eagle Nest Coordination Request, Six Projects In OLS Wooster Township, Wayne County

Thank You, Susan

---

**From:** gregory.k.eastridge@dominionenergy.com <gregory.k.eastridge@dominionenergy.com>  
**Sent:** Wednesday, January 12, 2022 11:04 AM  
**To:** Ohio, FW3 <ohio@fws.gov>  
**Subject:** [EXTERNAL] Bald Eagle Nest Coordination Request, Six Projects In OLS Wooster Township, Wayne County

**This email has been received from outside of DOI - Use caution before clicking on links, opening attachments, or responding.**



Good morning,

The East Ohio Gas Company, d/b/a/ Dominion Energy Ohio, is proposing to replace natural gas pipeline under the Pipeline Infrastructure Replacement (PIR) Program.

Six projects are proposed which fall in the Ohio Land Subdivision Township of Wooster Township in Wayne County. The names and associated coordinates of each project are provided below: Please provide a response indicating any adverse effect to the bald eagle.

Thank you,

Greg

PIR 2683 - Spruce Street

Small project centered at 40.787803, -81.941864

PIR 3081 - Cushman and Spink Street

Southwestern extent: 40.797897, -81.936766

Northeastern extent 40.800494, -81.930221

PIR 3635 - East University Street

Northwestern extent: 40.809919, -81.932305

Northeastern extent: 40.809821, -81.924604

Southeastern extent: 40.804396, -81.924696

Southwestern extent: 40.804952, -81.929714

PIR 2788 - Apple Creek

Southwestern extent: 40.802299, -81.900344

Northeastern extent: 40.804251, -81.896202

PIR 3564 - North Hillcrest Drive

Southern extent: 40.800989, -81.905649

Northern extent: 40.806360, -81.905638

Western extent: 40.806301, -81.910545

PIR 3553 - Ridgewood Drive

Western extent 40.834934, 81.934371

Eastern extent 40.834896, 81.929363

*Gregory K. Eastridge*  
*Environmental Specialist III*  
*Dominion Energy Environment and Sustainability*  
*320 Springside Drive, Suite 320*  
*Akron, Ohio 44333*  
*PH: (330) 664-2576*  
*Cell: (330) 571-7855*  
*Fax: (330) 664-2669*



Think before you print

CONFIDENTIALITY NOTICE: This electronic message contains information which may be legally confidential and or privileged and does not in any case represent a firm ENERGY COMMODITY bid or offer relating thereto which binds the sender without an additional express written confirmation to that effect. The information is intended solely for the individual or entity named above and access by anyone else is unauthorized. If you are not the intended recipient, any disclosure, copying, distribution, or use of the contents of this information is prohibited and may be unlawful. If you have received this electronic transmission in error, please reply immediately to the sender that you have received the message in error, and delete it. Thank you.



**ATTACHMENT J**  
**U.S. FISH AND WILDLIFE SERVICE BALD EAGLE COORDINATION EMAILS**

## Gregory K Eastridge (Services - 6)

---

**From:** Alyssa Dietz-Oergel <adietz-oergel@ectinc.com>  
**Sent:** Tuesday, January 23, 2024 12:29 PM  
**To:** ohio@fws.gov  
**Cc:** Gregory K Eastridge (Services - 6); Charlotte Moore  
**Subject:** [EXTERNAL] Project Submittal for Review (IPaC #2024-0039644)  
**Attachments:** PIR 2788\_Official IPaC Species List\_20240123.pdf; PIR 2788\_Attachment A\_Figures\_20240123.zip; PIR 2788\_Attachment B\_Photolog\_20240112.docx; PIR 2788\_Attachment C\_Bald Eagle Email\_20220201.pdf

**CAUTION! This message was NOT SENT from DOMINION ENERGY**

Are you expecting this message to your DE email? Suspicious? Use PhishAlarm to report the message. Open a browser and type in the name of the trusted website instead of clicking on links. DO NOT click links or open attachments until you verify with the sender using a known-good phone number. Never provide your DE password.

Good Afternoon,

The East Ohio Gas Company, d/b/a Dominion Energy Ohio (DEO), requests review of the following information regarding the Pipeline Infrastructure Replacement Program (PIR) project, PIR 2788 – Apple Creek Project. To assist with your review of the project, an official IPaC species list, site maps, and photographs are attached to this email.

### **Project Purpose, Description, and Location**

DEO is proposing to replace approximately 3,900 feet of twelve (12)–inch natural gas steel pipeline with 3,900 feet of twenty (20)–inch steel pipeline under the PIR program. The purpose of the program is to replace existing pipe to ensure the safety and reliability of pipeline operations.

The PIR 2788 project is located in Wooster Township, Wayne County along road right-of-way (ROW) of N. Hillcrest Drive, an existing sixty (60)-ft wide utility easement which originates at N. Hillcrest Drive and extends northeast to S. Geysers Chapel Road, and a newly acquired sixty (60)-foot wide easement which originates as a private drive on the east side of N. Hillcrest Drive and extends east to Apple Creek. The latitude and longitude coordinates for the center point of the project area are 40.802787°, -81.900774°. The project area is indicated on an excerpt of the Wooster Quadrangle, Ohio USGS 7.5-minute topographic map and ecological resources maps (attached). Representative photographs of the site are included in the attached documents.

### **Site Description**

Environmental field reviews of the project area were completed on May 13 and November 18, 2020, March 4 and April 30, 2021, and July 8, 2022. The surveys were performed to collect information on potential wetlands, streams, and protected species habitat. The study area is dominated by undeveloped, agricultural, and rural residential areas. The study area primarily has land cover of mature woods, active agricultural fields, fallow/old fields, maintained lawns, and emergent, scrub-shrub, and forested wetland areas.

One (1) wetland was identified within the project area and is shown on Figure 3 – Ecological Resources Map (attached). Wetland A is located within the floodplain north and south of Stream 1 (Apple Creek) and is composed of emergent, scrub-shrub, and forested vegetation communities. Emergent areas within Wetland A are dominated by the invasive species reed canary grass (*Phalaris arundinacea*). Common tree species within the forested portions of Wetland A include Ohio buckeye (*Aesculus glabra*), black cherry (*Prunus serotina*), and sycamore (*Platanus occidentalis*). In forested and scrub-shrub portions of the wetland, the understory is dense with cover from Ohio buckeye and black cherry saplings, as well as multiflora rose (*Rosa multiflora*). The northern boundary of Wetland A also runs along the edge of active row cropping. Previous and current disturbances to Wetland A include mowing, farming, clearcutting, and nutrient enrichment.

Six (6) streams are located within the study area and are shown in Attachment A. Stream 1 (Apple Creek) is a large perennial stream that flows east to west across the northeastern study area. Stream 2 is a small ephemeral stream located in the northeastern extent of the study area along Geyers Chapel Road and flows north to south into Stream 1 (Apple Creek). Stream 3 is a small ephemeral stream located in the southern portion of the study area. Stream 3 is culverted throughout most of the existing pipeline easement area, and flows south to north. Stream 4 is an intermittent stream located in the western study area along a potential site access route. Stream 4 drains north through the study area and Wetland A into Stream 1 (Apple Creek). Stream 5 is an ephemeral stream that originates in western portions of the study area and flows north towards Stream 1 (Apple Creek) where it eventually loses bed and bank within portions of Wetland A. Stream 6 is an ephemeral stream captured in a roadside ditch along the western edge of North Hillcrest Drive in the western portion of the study area. Representative photographs of the onsite water resources are included in Attachment B.

To complete the project, Wetland A and Streams 1 (Apple Creek), 4, 5, and 6 within road ROW of N. Hillcrest Drive and the utility easements will be temporarily impacted and will be open-cut trenched. Stream 2 will also be temporarily impacted for the installation of a temporary 40-ft wide culvert crossing for construction equipment. Stream 3 is located away from project activities and will be avoided. Following installation of the pipeline, temporarily disturbed areas will be restored to pre-construction grade and re-vegetated. No permanent impacts to these water resources will occur with the installation of pipeline for this project; however, temporarily impacted areas of forested or scrub/shrub wetland would be expected to exhibit a permanent emergent vegetation community. Impacts to Wetland A and Streams 1 (Apple Creek), 2, 4, 5, and 6 are anticipated to be authorized under a U.S. Army Corps of Engineers Nationwide Permit 12 for Oil or Natural Gas Pipeline activities.

Project construction activities (e.g., mowing/clearing, grading, trench excavation, spoil storage, backfilling, and restoration) will expose bare soils and increase the potential for erosion and sedimentation. Best Management Practices (BMPs) will be implemented throughout construction to minimize storm water runoff, soil erosion, the transport of sediments from the construction area, and to protect any aquatic resources located adjacent to the project area.

### **Federally Listed Species**

DEO generated an official Information for Planning and Consultation (IPaC) species list for the project area on January 23, 2024 (attached). Federally species from the official IPaC list are discussed below:

- All counties in Ohio are within the range of the federally-listed endangered Indiana bat (*Myotis sodalis*), the federally-listed endangered northern long-eared bat (*Myotis septentrionalis*), and the tricolored bat (*Permyotis subflavus*) which is proposed for federal listing as endangered. Summer habitat requirements for these species are not well defined, but the following are considered important: dead or live trees and snags with peeling or exfoliating bark, split tree trunk and/or branches, or cavities, which may be used as maternity roost areas; live trees (such as shagbark hickory and oaks) which have exfoliating bark; and stream corridors, riparian areas, and upland woodlots which provide forage sites. Occasionally the northern long-eared bat may roost in structures like barns and sheds.

Eleven (11) trees were identified with characteristics which may potentially provide some level of roosting habitat for bats. The locations of these trees are indicated on the attached Figure 3. Photographs of typical potential habitat trees are also attached. To complete the project, DEO may need to cut some of the potential roost trees. DEO proposes to conduct all tree clearing of these trees between October 1 and March 31.

- The monarch butterfly (*Danaus pleippus*) is a federal candidate species. Although the monarch butterfly is known to forage on many wildflowers, monarch butterflies prefer open fields and meadows with milkweeds (*Asclepias* spp.), its larval host plant. The construction area of the project consists of road ROW dominated by riparian forest, agricultural fields, maintained lawns, and pavement. Suitable habitat for the monarch butterfly does not occur within the project area and therefore this species would not be expected to be adversely impacted by this project.



- The federally threatened eastern prairie fringed orchid (*Platanthera leucophaea*) prefers habitats of prairie and wetland habitat including sedge meadows and marshes. The study area is primarily composed of forested areas and disturbed land covers including active row crops, old field, and pavement. Although an area of emergent wetland is located within the study area, this is dominated by invasive species and unlikely to provide habitat for the eastern prairie fringed orchid. Therefore, the eastern prairie fringed orchid would not be expected to be adversely impacted by this project.
- The bald eagle (*Haliaeetus leucocephalus*) is protected under the Bald and Golden Eagle Protection Act. Bald eagle habitat includes areas adjacent to water bodies that provide suitable feeding (lakes, rivers, oceans) and must include large trees appropriate for roosting and nesting. No bald eagles or nest sites were observed during fieldwork. Additionally, previous email coordination with USFWS on January 25, 2022 confirmed that no known bald eagle nests occur within 0.5 mile of the PIR 2788 project (attached). Therefore, adverse impacts to the bald eagle are not expected for this project.

### **Request for Finding**

Considering the information above, DEO is requesting a finding from the USFWS regarding any adverse effect to federally listed, threatened, or endangered species in the project area.

A timely response is respectfully requested to ensure compliance with the Endangered Species Act prior to initiating activities. Please forward your response via email at the earliest possible convenience to the attention of Greg Eastridge at [Gregory.K.Eastridge@dominionenergy.com](mailto:Gregory.K.Eastridge@dominionenergy.com).

If you have any questions or need additional information, please contact Greg Eastridge at (330) 664-2576.

Sincerely,

**Alyssa Dietz-Oergel**

Senior Associate Scientist

Natural Resources

M: 216.513.4893

[ectinc.com]



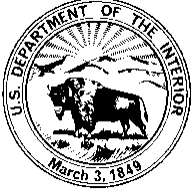
Follow us:



[\[linkedin.com\]](https://www.linkedin.com)[\[facebook.com\]](https://www.facebook.com)[\[twitter.com\]](https://www.twitter.com)[\[youtube.com\]](https://www.youtube.com)

**ATTACHMENT K**  
**U.S. FISH AND WILDLIFE SERVICE IPAC SUMMARY**

# United States Department of the Interior



## FISH AND WILDLIFE SERVICE

Ecological Services  
4625 Morse Road, Suite 104  
Columbus, Ohio 43230  
(614) 416-8993 / FAX (614) 416-8994



January 26, 2024

Project Code: 2024-0039644

Dear Alyssa Dietz-Oergel:

The U.S. Fish and Wildlife Service (Service) has received your recent correspondence requesting information about the subject proposal. We offer the following comments and recommendations to assist you in minimizing and avoiding adverse impacts to threatened and endangered species pursuant to the Endangered Species Act of 1973 (16 U.S.C. 1531 et seq), as amended (ESA).

Federally Threatened and Endangered Species: Due to the project type, size, location, and the proposed implementation of seasonal tree cutting (clearing of trees  $\geq 3$  inches diameter at breast height between October 1 and March 31) to avoid impacts to the endangered Indiana bat (*Myotis sodalis*) and northern long-eared bat (*Myotis septentrionalis*), and the proposed endangered tricolored bat (*Perimyotis subflavus*) we do not anticipate adverse effects to any other federally endangered, threatened, or proposed species, or proposed or designated critical habitat. Should the project design change, or additional information on listed or proposed species or their critical habitat become available, or if new information reveals effects of the action that were not previously considered, coordination with the Service should be initiated to assess any potential impacts.

Section 7 Coordination: If there is a federal nexus for the project (e.g., federal funding provided, federal permits required to construct), then no tree clearing should occur on any portion of the project area until consultation under section 7 of the ESA, between the Service and the federal action agency, is completed. We recommend the federal action agency submit a determination of effects to this office, relative to the Indiana bat and northern long-eared bat, for our review and concurrence. This letter provides technical assistance only and does not serve as a completed section 7 consultation document.

Stream and Wetland Avoidance: Over 90% of the wetlands in Ohio have been drained, filled, or modified by human activities, thus is it important to conserve the functions and values of the remaining wetlands in Ohio ([https://epa.ohio.gov/portals/47/facts/ohio\\_wetlands.pdf](https://epa.ohio.gov/portals/47/facts/ohio_wetlands.pdf)). We recommend avoiding and minimizing project impacts to all wetland habitats (e.g., forests, streams, vernal pools) to the maximum extent possible in order to benefit water quality and fish and wildlife habitat. Additionally, natural buffers around streams and wetlands should be preserved to enhance beneficial functions. If streams or wetlands will be impacted, the U.S. Army Corps of Engineers should be contacted to determine whether a Clean Water Act section 404 permit is required. Best management practices should be used to minimize erosion, especially on slopes. Disturbed areas should be mulched and revegetated with native plant



species. In addition, prevention of non-native, invasive plant establishment is critical in maintaining high quality habitats.

Thank you for your efforts to conserve listed species and sensitive habitats in Ohio. We recommend coordinating with the Ohio Department of Natural Resources due to the potential for the proposed project to affect state listed species and/or state lands. Contact Mike Pettegrew, Environmental Services Administrator, at (614) 265-6387 or at [mike.pettegrew@dnr.ohio.gov](mailto:mike.pettegrew@dnr.ohio.gov).

If you have questions, or if we can be of further assistance in this matter, please contact our office at (614) 416-8993 or [ohio@fws.gov](mailto:ohio@fws.gov).

Sincerely,

A handwritten signature in blue ink that reads "Scott Hicks". The signature is written in a cursive style.

Scott Hicks  
Acting Field Office Supervisor

**ATTACHMENT L**  
**U.S. FISH AND WILDLIFE SERVICE RESPONSE**

January 29, 2024

**BY EMAIL**

Michael Pettegrew  
Ohio Department of Natural Resources  
Office of Real Estate  
2045 Morse Road, Building E-2  
Columbus, Ohio 43229-6693

**RE: The East Ohio Gas Company, Pipeline Infrastructure Replacement Program  
Ohio Listed Species Consultation  
PIR 2788 – Apple Creek**

Dear Mr. Pettegrew:

The East Ohio Gas Company, d/b/a Dominion Energy Ohio (DEO), requests review of the following information regarding the Pipeline Infrastructure Replacement (PIR) project, PIR 2788 – Apple Creek project. To assist with your review of the project, site maps and photographs are enclosed.

**Project Purpose, Description, and Location**

DEO is proposing to install approximately 3,900 feet of twenty (20)-inch steel pipeline to replace one section of existing pipeline and relocate another section of existing pipeline. This work will be conducted under the PIR program. The purpose of the program is to replace existing pipe to ensure the safety and reliability of pipeline operations.

The PIR 2788 project is located in Wooster Township, Wayne County within the road right-of-way (ROW) of N. Hillcrest Drive, an existing sixty (60)-ft wide utility easement which originates at N. Hillcrest Drive and extends northeast to S. Geyers Chapel Road, and a newly acquired sixty (60)-foot wide easement which originates as a private drive on the east side of N. Hillcrest Drive and extends east to Apple Creek. The latitude and longitude coordinates for the center point of the project area are 40.802787°, -81.900774°. The project area is indicated on an excerpt of the Wooster Quadrangle, Ohio USGS 7.5-minute topographic map and ecological resources maps, located in Attachment A. Representative photographs of the site are included in Attachment B.

**Site Description**

An environmental field review of the study area was completed on May 13 and November 18, 2020, March 4 and April 30, 2021, and July 8, 2022. The study area is dominated by undeveloped, agricultural, and rural residential areas. The study area primarily has land cover of mature woods, active agricultural fields, fallow/old fields, maintained lawns, and emergent, scrub-shrub, and forested wetland areas.



One (1) wetland was identified within the project area and is shown on Figure 2 – Ecological Resources Map (Attachment A).

Wetland A is located within the floodplain north and south of Stream 1 (Apple Creek) and is composed of emergent, scrub-shrub, and forested vegetation communities. Emergent areas within Wetland A are dominated by the invasive species reed canary grass (*Phalaris arundinacea*). Common tree species within the forested portions of Wetland A include Ohio buckeye (*Aeculus glabra*), black cherry (*Prunus serotina*), and sycamore (*Platanus occidentalis*). In forested and scrub-shrub portions of the wetland, the understory is dense with cover from Ohio buckeye and black cherry saplings, as well as multiflora rose (*Rosa multiflora*). The northern boundary of Wetland A is bordered by active row cropping. Previous and current disturbances to Wetland A include mowing, farming, clearcutting, and nutrient enrichment.

Six (6) streams are located within the study area and are shown in Attachment A. Stream 1 (Apple Creek) is a large perennial stream that flows east to west across the northeastern study area. Stream 2 is a small ephemeral stream located in the northeastern extent of the study area along Geyers Chapel Road and flows north to south into Stream 1 (Apple Creek). Stream 3 is a small ephemeral stream located in the southern portion of the study area. Stream 3 is culverted throughout most of the exiting pipeline easement area, and flows south to north. Stream 4 is an intermittent stream located in the western portion of the study area. Stream 4 drains north through the study area and Wetland A into Stream 1 (Apple Creek). Stream 5 is an ephemeral stream that originates in western portions of the study area and flows north towards Stream 1 (Apple Creek) where it eventually loses bed and bank within portions of Wetland A. Stream 6 is an ephemeral stream captured in a roadside ditch along the western edge of North Hillcrest Drive in the eastern portion of the study area. Representative photographs of the onsite water resources are included in Attachment B.

To complete the project, Wetland A and Streams 1 (Apple Creek), 4, 5, and 6 within road ROW of N. Hillcrest Drive and the utility easements will be temporarily impacted and will be open-cut trenched. Stream 2 will also be temporarily impacted for the installation of a temporary 40-ft wide culvert crossing for construction equipment. Stream 3 is located away from project activities and will be avoided. Following installation of the pipeline, temporarily disturbed areas will be restored to pre-construction grade and re-vegetated. No permanent impacts to these water resources will occur with the installation of pipeline for this project; however, temporarily impacted areas of forested or scrub/shrub wetland would be expected to exhibit a permanent emergent vegetation community, post-construction.

The project area was reviewed for habitat which could be suitable for protected bat species. Eleven (11) trees were identified within the project area with potential summer roosting habitat for the listed bats. The location of these trees are indicated on the Ecological Resources Maps in Attachment A. Photographs of representative potential habitat trees are included in Attachment B. No trees suitable for maternity roosts were

identified within the project area. To complete the project, DEO may need to cut some of the identified potential roosting trees. Additionally, tree and shrub clearing will be necessary within the easement. DEO proposes to conduct all tree clearing between October 1 and March 31.

Project construction activities (e.g., mowing/clearing, grading, trench excavation, spoil storage, backfilling, and restoration) will expose bare soils and increase the potential for erosion and sedimentation. Best Management Practices (BMPs) will be implemented throughout construction to minimize stormwater runoff, soil erosion, the transport of sediments from the construction area, and to protect the aquatic resources located in and/or adjacent to the project area.

### **Request for Finding**

Considering the information above, DEO is requesting a finding regarding any adverse effect to any state-listed species and natural areas with ecological and/or geological significance. A response is respectfully requested to ensure compliance relative to state-listed endangered species prior to initiating activities.

An email response would be greatly appreciated. Please send the email to Greg Eastridge at [gregory.k.eastridge@dominionenergy.com](mailto:gregory.k.eastridge@dominionenergy.com). If you have any questions or need additional information, please contact Greg Eastridge at (330) 664-2576.

Sincerely,



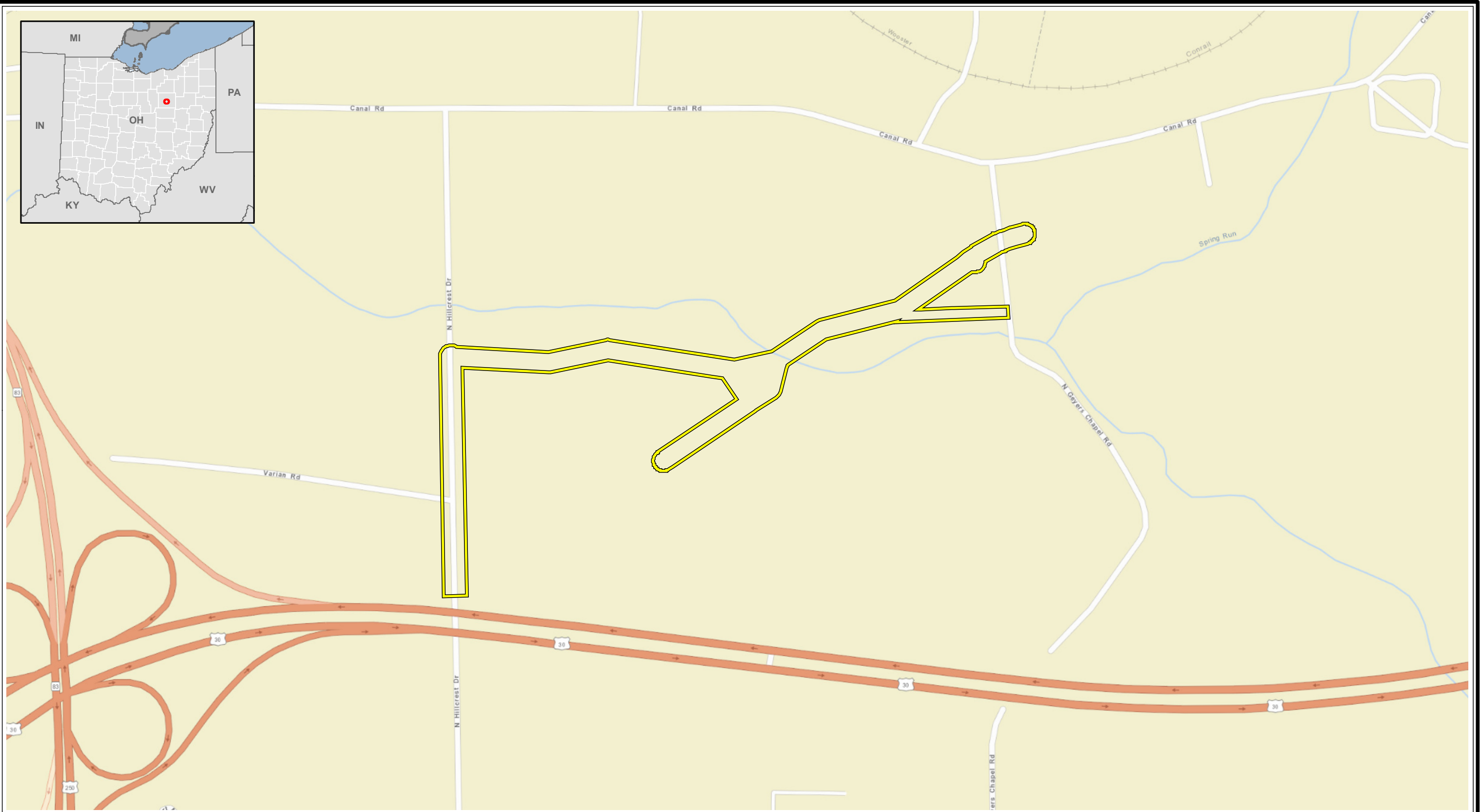
Darrell R. Shier  
Authorized Representative  
Manager, Environmental Services

Enclosures

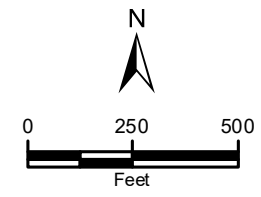
cc: Greg Eastridge

**Attachment A**  
**Maps**





 Project Study Area



Base Layer: ESRI Street Map 2019

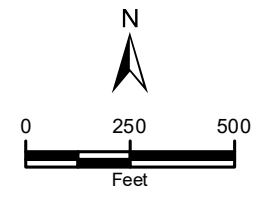
**Figure 1**  
**Site Location**  
PIR 2788 - Apple Creek  
Dominion Energy Ohio  
Wayne County, Ohio  
Date: 11/29/2023







 Project Study Area



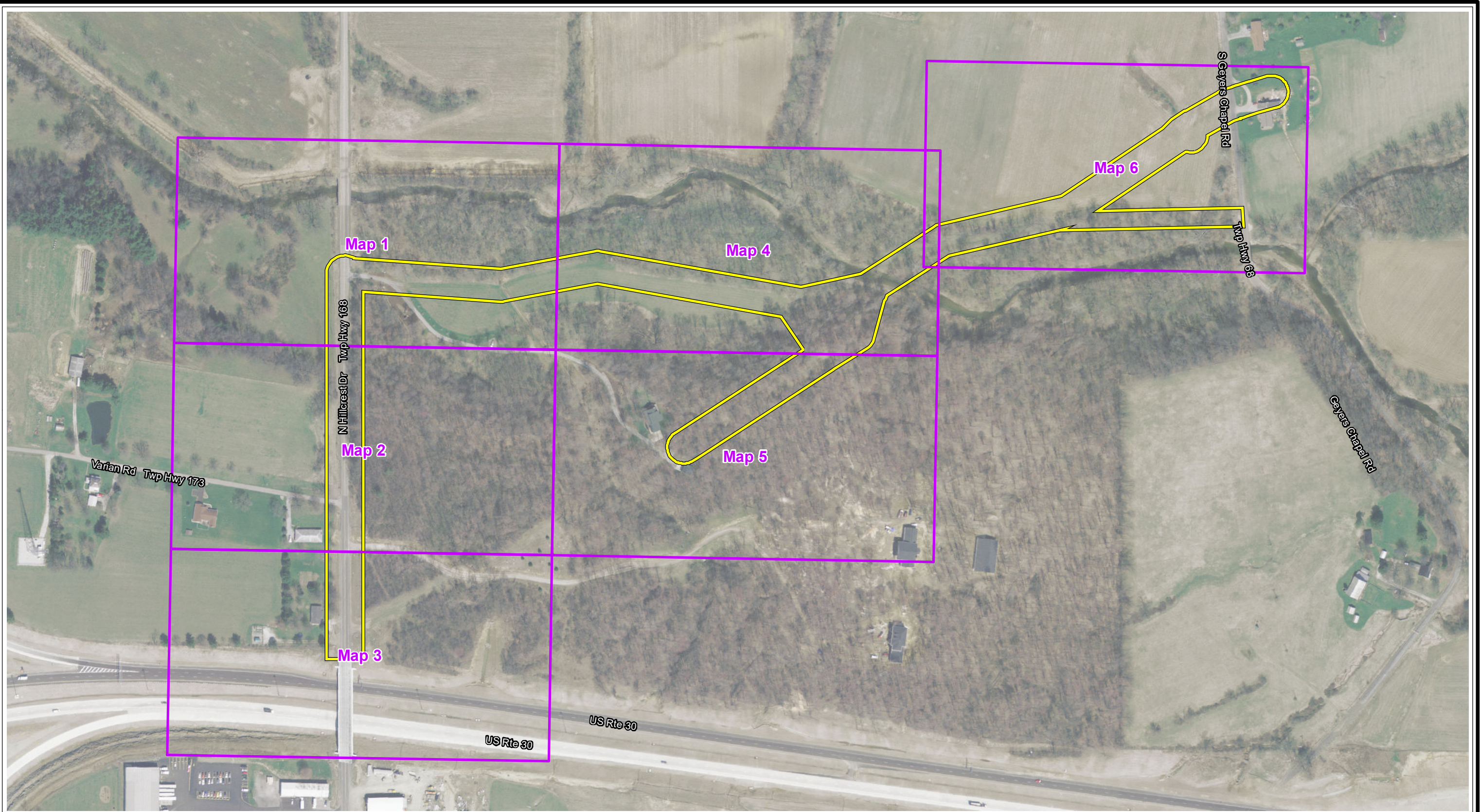
Base Layer: US TopoMaps, 1998

**Figure 2**  
**USGS Topographic - Wooster Quadrangle**

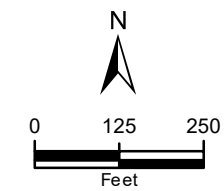
PIR 2788 - Apple Creek  
Dominion Energy Ohio  
Wayne County, Ohio  
Date: 11/29/2023







Project Study Area  
 Map Extent



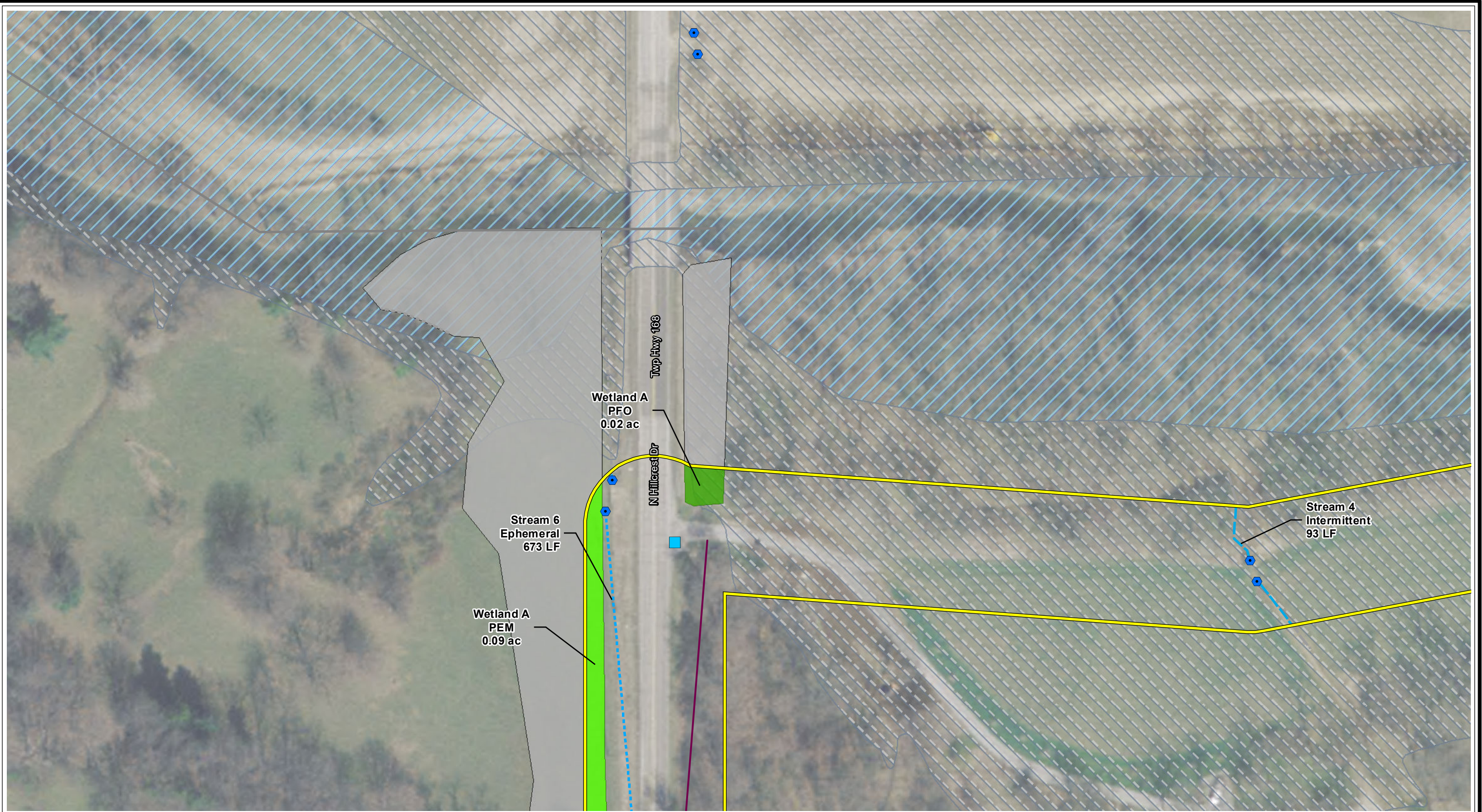
Base Layer: OSIP 2016

**Figure 3**  
**Ecological Resources Map Book**

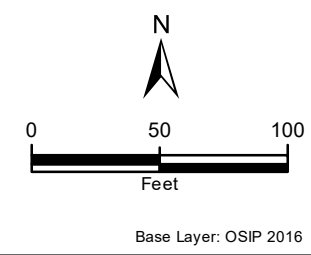
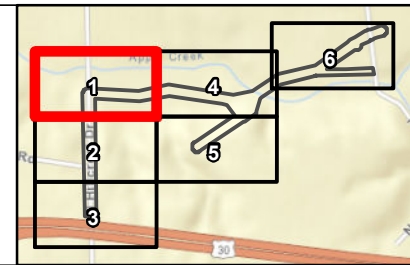
PIR 2788 - Apple Creek  
 Dominion Energy Ohio  
 Wayne County, Ohio  
 Date: 10/26/2023








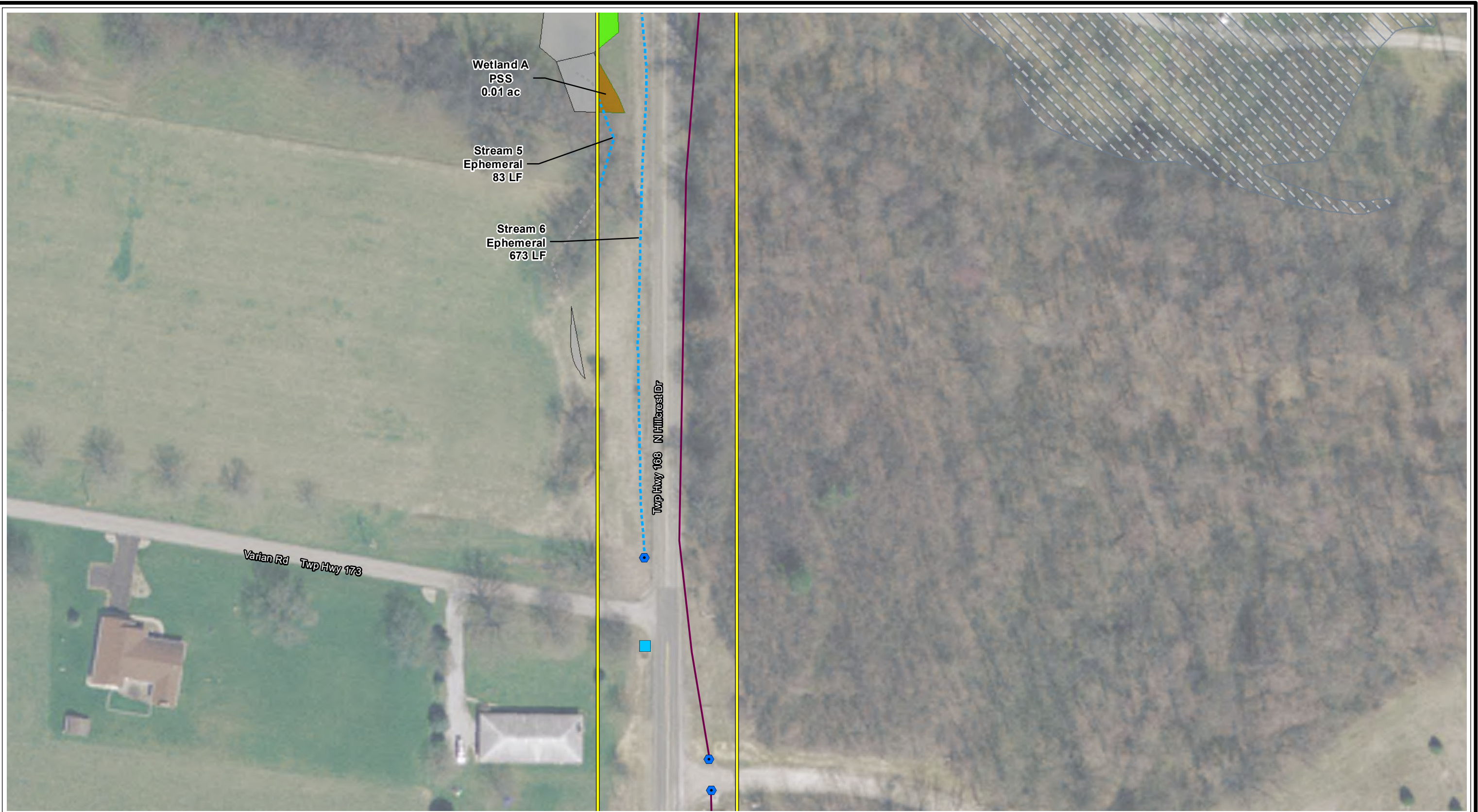
- |                      |                              |                               |
|----------------------|------------------------------|-------------------------------|
| Project Study Area   | Delineated Stream            | Delineated Wetlands           |
| Stormwater Inlet     | On-site Perennial Stream     | On-site Emergent Wetland      |
| Culvert              | Off-site Perennial Stream    | On-site Forested Wetland      |
| Potential Roost Tree | On-site Intermittent Stream  | On-site Shrub Scrub Wetland   |
| Temp Pipeline Marker | Off-site Intermittent Stream | Off-Site Wetland              |
| Perm Pipeline Marker | On-site Ephemeral Stream     | Flood Zones (FEMA)            |
| Delineated Ditch     | Off-site Ephemeral Stream    | 1% Annual Chance Flood Hazard |
|                      |                              | Regulatory Floodway           |



**Figure 3**  
**Ecological Resources Map 1 of 6**  
 PIR 2788 - Apple Creek  
 Dominion Energy Ohio  
 Wayne County, Ohio  
 Date: 11/21/2023







Wetland A  
PSS  
0.01 ac

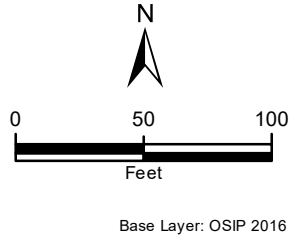
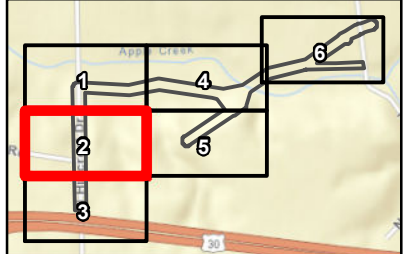
Stream 5  
Ephemeral  
83 LF

Stream 6  
Ephemeral  
673 LF

Twp Hwy 168 N Hillcrest Dr

Varian Rd Twp Hwy 173

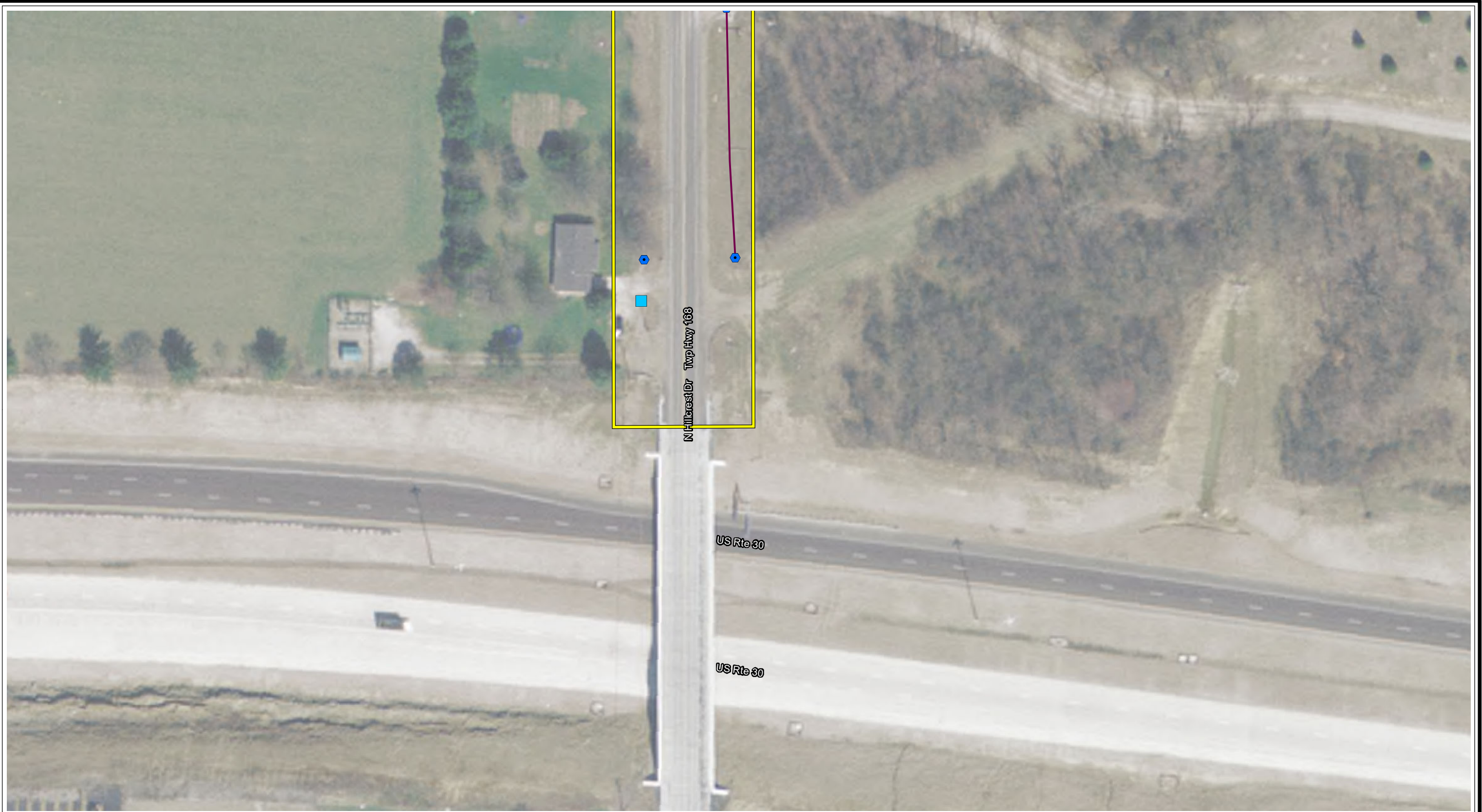
- |                       |                              |                               |
|-----------------------|------------------------------|-------------------------------|
| Project Study Area    | Delineated Stream            | Delineated Wetlands           |
| Stormwater Inlet      | On-site Perennial Stream     | On-site Emergent Wetland      |
| Culvert               | Off-site Perennial Stream    | On-site Forested Wetland      |
| Potential Roost Treet | On-site Intermittent Stream  | On-site Shrub Scrub Wetland   |
| Temp Pipeline Marker  | Off-site Intermittent Stream | Off-Site Wetland              |
| Perm Pipeline Marker  | On-site Ephemeral Stream     | Flood Zones (FEMA)            |
| Delineated Ditch      | Off-site Ephemeral Stream    | 1% Annual Chance Flood Hazard |
|                       |                              | Regulatory Floodway           |



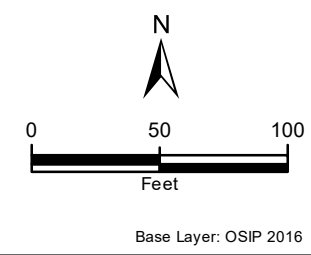
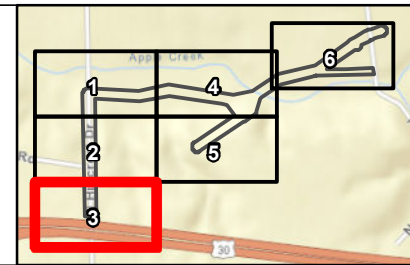
**Figure 3**  
**Ecological Resources Map 2 of 6**  
PIR 2788 - Apple Creek  
Dominion Energy Ohio  
Wayne County, Ohio  
Date: 11/21/2023







- |                      |                              |                               |
|----------------------|------------------------------|-------------------------------|
| Project Study Area   | Delineated Stream            | Delineated Wetlands           |
| Stormwater Inlet     | On-site Perennial Stream     | On-site Emergent Wetland      |
| Culvert              | Off-site Perennial Stream    | On-site Forested Wetland      |
| Potential Roost Tree | On-site Intermittent Stream  | On-site Shrub Scrub Wetland   |
| Temp Pipeline Marker | Off-site Intermittent Stream | Off-Site Wetland              |
| Perm Pipeline Marker | On-site Ephemeral Stream     | Flood Zones (FEMA)            |
| Delineated Ditch     | Off-site Ephemeral Stream    | 1% Annual Chance Flood Hazard |
|                      |                              | Regulatory Floodway           |

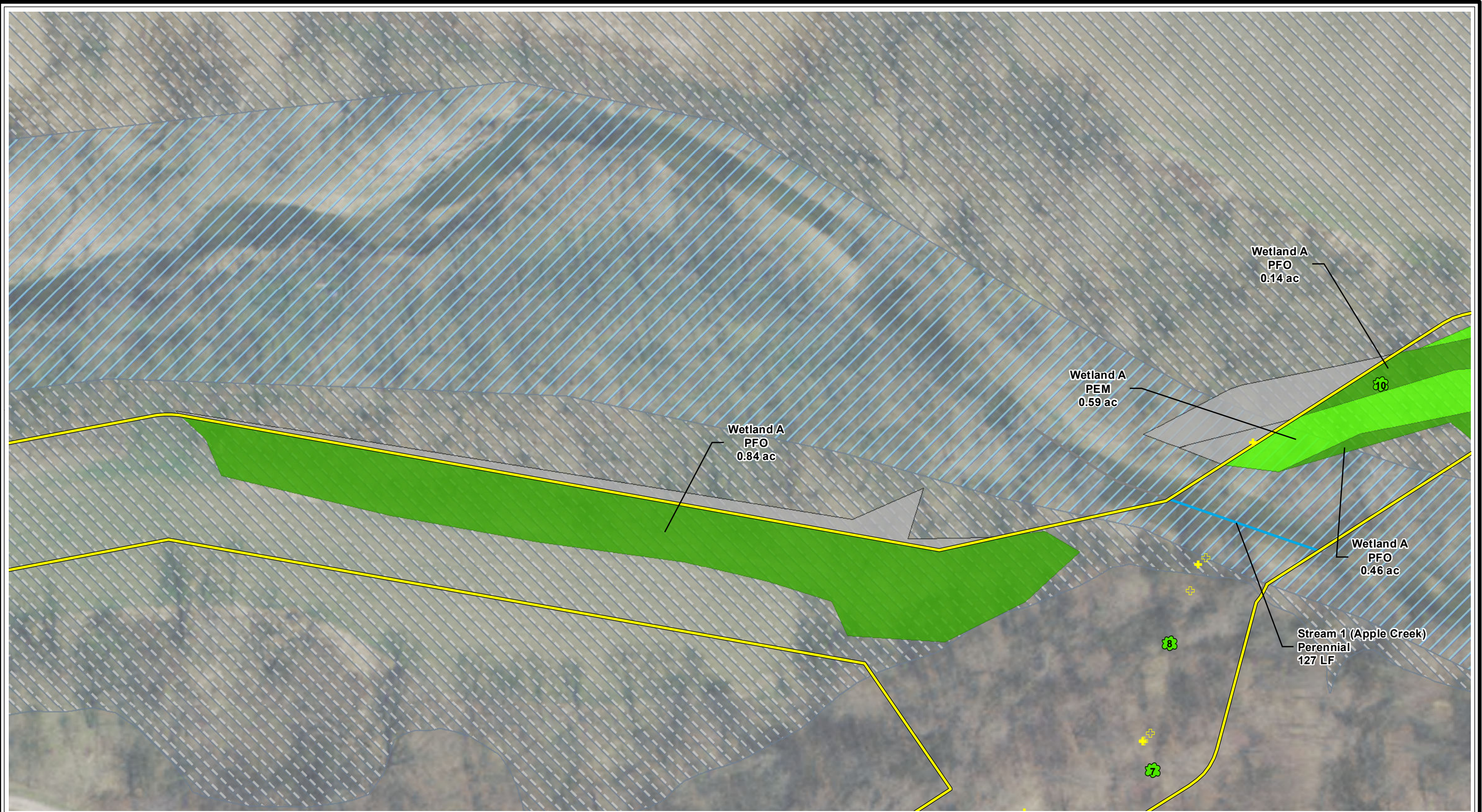


**Figure 3**  
**Ecological Resources Map 3 of 6**

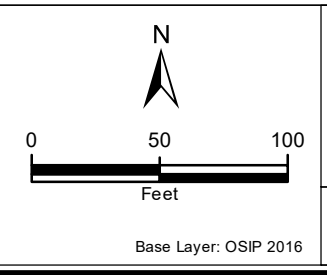
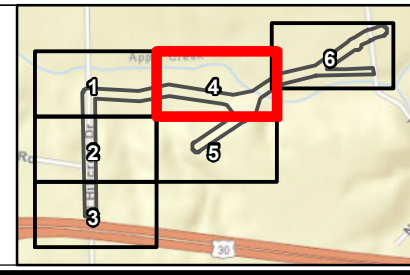
PIR 2788 - Apple Creek  
 Dominion Energy Ohio  
 Wayne County, Ohio  
 Date: 11/21/2023








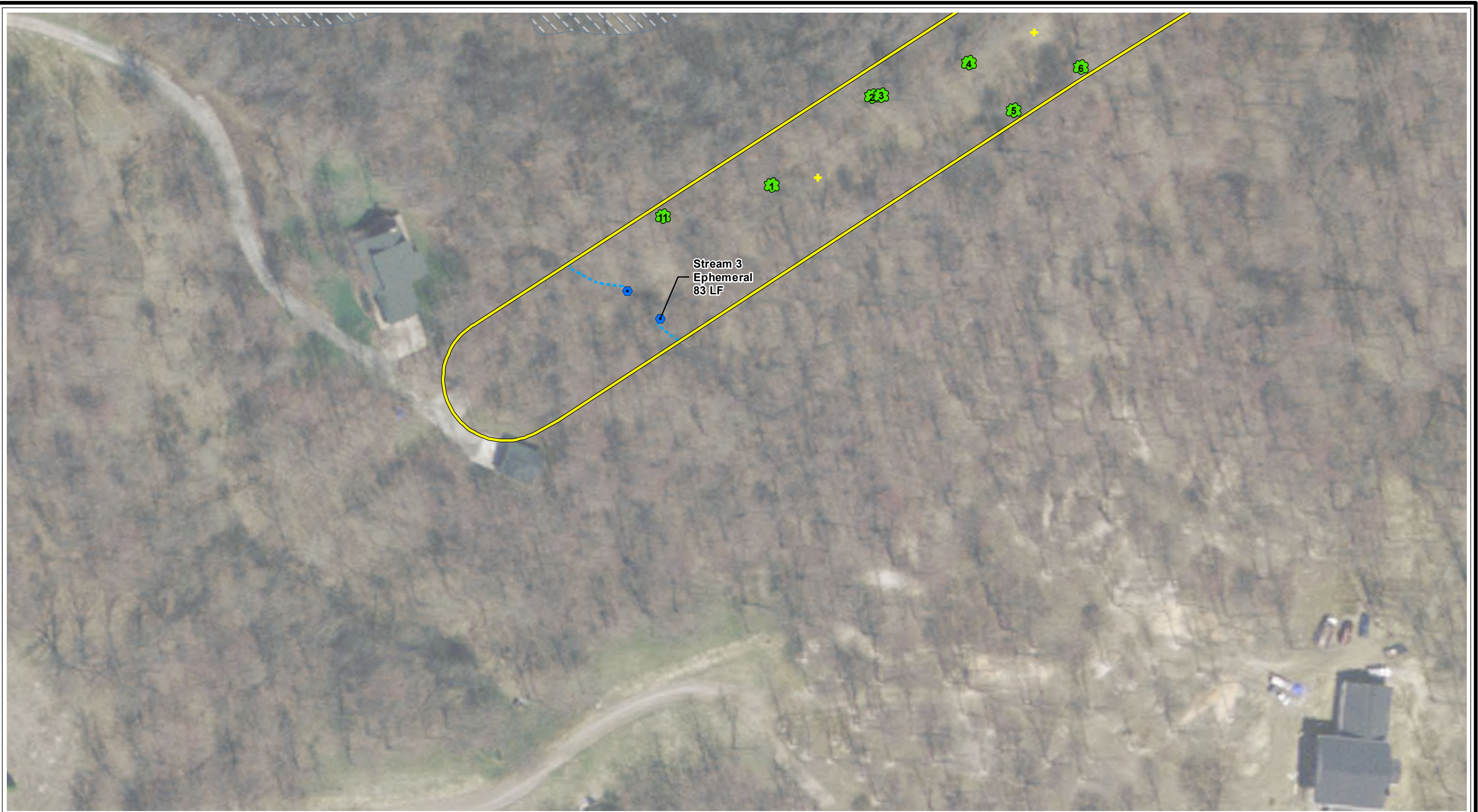
Project Study Area	Delineated Stream	Delineated Wetlands
Stormwater Inlet	On-site Perennial Stream	On-site Emergent Wetland
Culvert	Off-site Perennial Stream	On-site Forested Wetland
Potential Roost Tree	On-site Intermittent Stream	On-site Shrub Scrub Wetland
Temp Pipeline Marker	Off-site Intermittent Stream	Off-Site Wetland
Perm Pipeline Marker	On-site Ephemeral Stream	Flood Zones (FEMA)
Delineated Ditch	Off-site Ephemeral Stream	1% Annual Chance Flood Hazard
		Regulatory Floodway



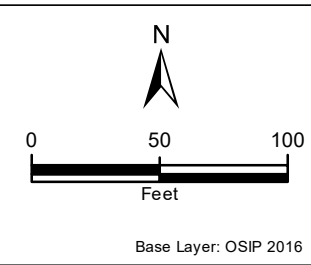
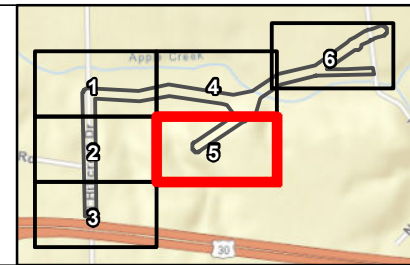
**Figure 3**  
**Ecological Resources Map 4 of 6**  
 PIR 2788 - Apple Creek  
 Dominion Energy Ohio  
 Wayne County, Ohio  
 Date: 11/21/2023







Project Study Area	Delineated Stream	Delineated Wetlands
Stormwater Inlet	On-site Perennial Stream	On-site Emergent Wetland
Culvert	Off-site Perennial Stream	On-site Forested Wetland
Potential Roost Tree	On-site Intermittent Stream	On-site Shrub Scrub Wetland
Temp Pipeline Marker	Off-site Intermittent Stream	Off-Site Wetland
Perm Pipeline Marker	On-site Ephemeral Stream	Flood Zones (FEMA)
Delineated Ditch	Off-site Ephemeral Stream	1% Annual Chance Flood Hazard
		Regulatory Floodway

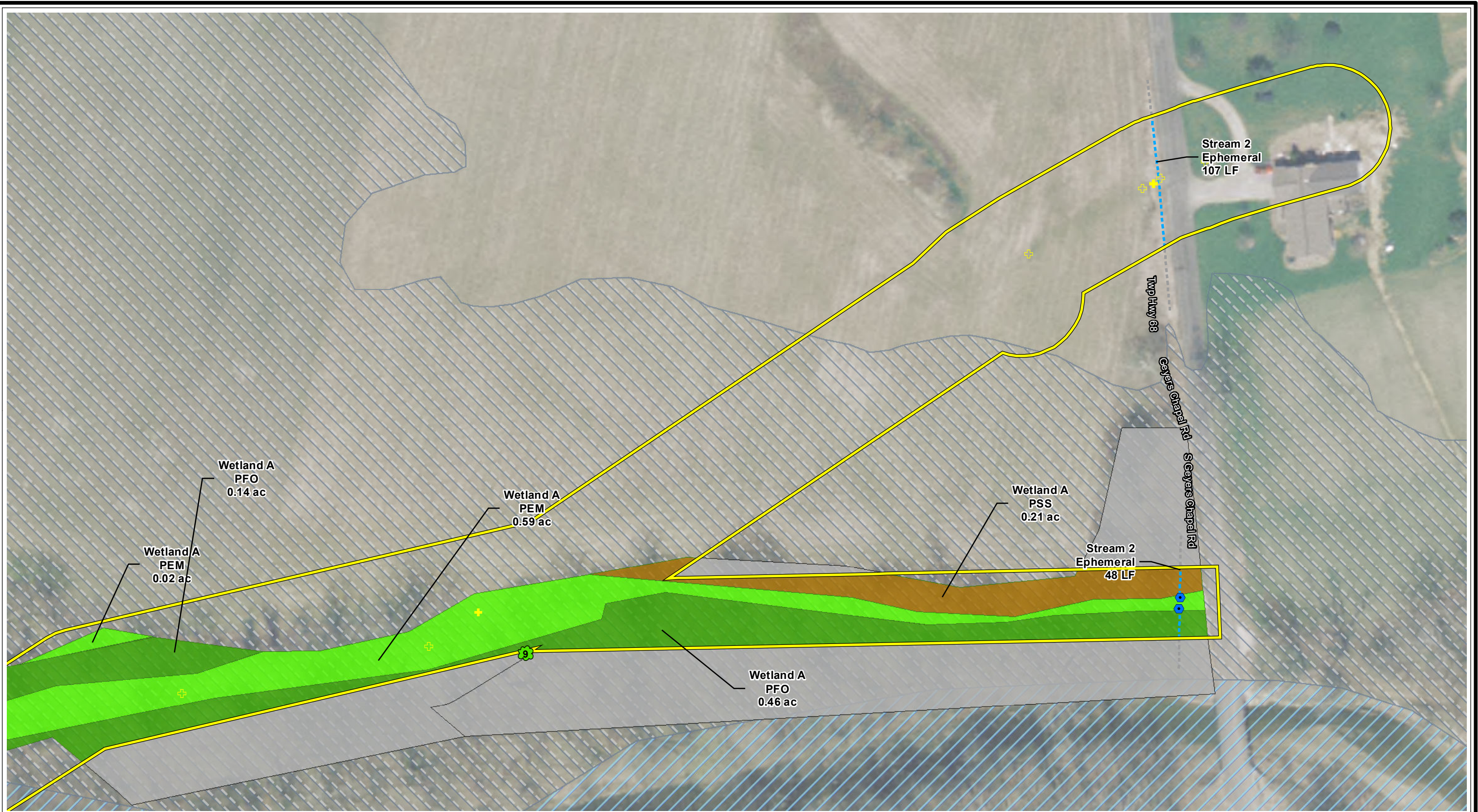


**Figure 3**  
**Ecological Resources Map 5 of 6**

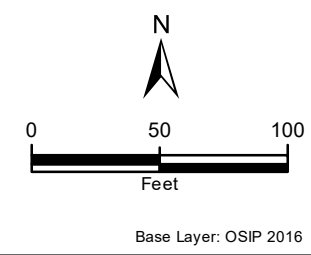
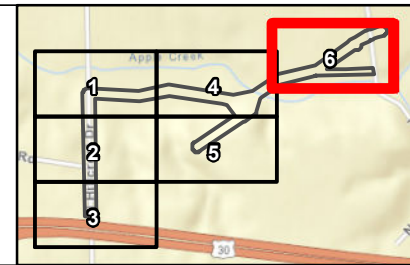
PIR 2788 - Apple Creek  
Dominion Energy Ohio  
Wayne County, Ohio  
Date: 11/21/2023








- |                      |                              |                               |
|----------------------|------------------------------|-------------------------------|
| Project Study Area   | Delineated Stream            | Delineated Wetlands           |
| Stormwater Inlet     | On-site Perennial Stream     | On-site Emergent Wetland      |
| Culvert              | Off-site Perennial Stream    | On-site Forested Wetland      |
| Potential Roost Tree | On-site Intermittent Stream  | On-site Shrub Scrub Wetland   |
| Temp Pipeline Marker | Off-site Intermittent Stream | Off-Site Wetland              |
| Perm Pipeline Marker | On-site Ephemeral Stream     | Flood Zones (FEMA)            |
| Delineated Ditch     | Off-site Ephemeral Stream    | 1% Annual Chance Flood Hazard |
|                      |                              | Regulatory Floodway           |




**Figure 3**  
**Ecological Resources Map 6 of 6**  
 PIR 2788 - Apple Creek  
 Dominion Energy Ohio  
 Wayne County, Ohio  
 Date: 11/21/2023






**Attachment B**  
**Photographs**


> **Photographic Log**


<b>Photo # 1</b>	
Date: 05/13/2020	
Feature: Upland easement	
Description: The study area, located south of Stream 1 (Apple Creek), contains upland mowed easement forested areas.	

<b>Photo # 2</b>	
Date: 05/13/2020	
Feature: Agricultural Areas	
Description: The northern study area overlaps with active agricultural fields.	



> **Photographic Log**


<b>Photo # 3</b>	
Date: 04/30/2021	
Feature: Fallow Field/Lawn	
Description: The western study area overlaps with a newly fallow field/maintained lawn along the edge of a forested wetland (Wetland A).	

<b>Photo # 4</b>	
Date: 05/13/2020	
Feature: Residential Area	
Description: The northern extent of the study area abuts a residential property along Geyers Chapel Road.	



> **Photographic Log**


<b>Photo # 5</b>	
Date: 05/13/2020	
Feature: Wet -A, South	
Description: The photo depicts datapoint Wet-A, located in Wetland A on the northern side of Apple Creek.	

<b>Photo # 6</b>	
Date: 04/30/2021	
Feature: Wet -A2, North	
Description: The photo depicts datapoint Wet-A2, located in Wetland A on the southern side of Apple Creek.	




> **Photographic Log**

<b>Photo # 7</b>	
Date: 05/13/2020	
Feature: Stream 1 (Apple Creek), Downstream	
Description: The photo depicts a downstream view of Stream 1 (Apple Creek).	

<b>Photo # 8</b>	
Date: 05/13/2020	
Feature: Stream 2, Upstream	
Description: Stream 2 flows north to south through the northeastern extent of the study area and is channelized along Geyers Chapel Road. The photo depicts an upstream view of Stream 2.	




> **Photographic Log**


<b>Photo # 9</b>	
Date: 03/04/2021	
Feature: Stream 3, Downstream	
Description: The photo depicts a downstream view of Stream 3.	

<b>Photo # 10</b>	
Date: 04/30/2021	
Feature: Stream 4, Upstream	
Description: The photo depicts an upstream view of Stream 4.	



> **Photographic Log**

<b>Photo # 11</b>	 A photograph showing a downstream view of Stream 5. The stream is a narrow, shallow channel with a rocky bed, surrounded by dense, tangled vegetation and fallen branches. The water is clear and flows over the rocks.
Date: 11/18/2020	
Feature: Stream 5, Downstream	
Description: The photo depicts a downstream view of Stream 5.	

<b>Photo # 12</b>	 A photograph showing an upstream view of Stream 6. The stream is a narrow, shallow channel with a rocky bed, surrounded by dense, tangled vegetation and fallen branches. The water is clear and flows over the rocks.
Date: 11/18/2020	
Feature: Stream 6, Upstream	
Description: Stream 6 is an ephemeral stream that is entirely captured within a ditch channel along the west side of North Hillcrest Drive. The photo depicts an upstream view of Stream 6.	



> **Photographic Log**

<b>Photo # 13</b>
Date: 05/13/2020
Feature: Tree 2
Description: <i>Carya ovata</i>



<b>Photo # 14</b>
Date: 05/13/2020
Feature: Tree 4
Description: <i>Tilia americana</i>



> **Photographic Log**

<b>Photo # 15</b>
Date: 05/13/2020
Feature: Tree 10
Description: <i>Acer negundo</i>



<b>Photo # 16</b>
Date: 03/04/2021
Feature: Tree 11
Description: <i>Prunus serotina</i>





**ATTACHMENT M**  
**OHIO DEPARTMENT OF NATURAL RESOURCES COORDINATION**



January 26, 2024

**BY EMAIL**

Lee Robinette  
Regulatory Chief, Huntington Regulatory District  
United States Army Corps of Engineers,  
502 Eighth Street  
Huntington, WV 25701

**RE: The East Ohio Gas Company, Pipeline Infrastructure Replacement Program  
Pre-Construction Notification for Nationwide Permit #12  
The East Ohio Gas Company, d/b/a Dominion Energy Ohio (DEO) –  
PIR 2788 – Apple Creek**

Dear Ms. Robinette:

The East Ohio Gas Company, d/b/a Dominion Energy Ohio (DEO), herein transmits one (1) electronic copy of a Pre-Construction Notification (PCN) pursuant to a United States Army Corps of Engineers Nationwide Permit 12 for the PIR 2788 – Apple Creek project.

To assist with review of the project, supporting documentation is enclosed:

- Complete Application Form 6082 (including additional sheets)
- Project Site Plan Maps (Attachment A)
- Aquatic Resources Delineation Report (Attachment B)
- Typical Construction Drawings (Attachment C)
- Issued USFWS Review Letter and Ohio Department of Natural Resources Coordination (Attachment D)
- Ohio Historic Preservation Office Resource Map (Attachment E)

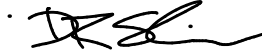
DEO expects to initiate construction in June 2024 with construction ending in late 2024; however, tree cutting will be necessary prior to April 1. Per Regulatory Guidance Letter 16-01, DEO is requesting all water resources on this site be considered Waters of the United States, as such, it is understood a Pre-JD is not necessary.

Please review the enclosed materials for completeness and forward your response to the attention of:

Greg Eastridge, Environmental Specialist  
320 Springside Drive, Suite 320  
Akron, Ohio 44333  
gregory.k.eastridge@dominionenergy.com

If you have any questions or need additional information, please contact Greg Eastridge at (330) 664-2576.

Sincerely,

A handwritten signature in black ink, appearing to read 'DRS', with a horizontal flourish extending to the right.

Darrell R. Shier  
Authorized Representative  
Manager Environmental Services

Enclosures

cc: Greg Eastridge







permanent conversion of forested wetlands. See additional sheets for details.

25. Is any portion of the nationwide permit activity already complete?  Yes  No If Yes, describe the completed work:

26. List the name(s) of any species listed as endangered or threatened under the Endangered Species Act that might be affected by the proposed NWP activity or utilize the designated critical habitat that might be affected by the proposed NWP activity. (see instructions)  
Indiana bat (*Myotis sodalis*), northern long-eared bat (*M. septentrionalis*), tricolored bat (*Perimyotis subflavus*), monarch butterfly (*Danaus plexippus*), and eastern prairie fringed orchid (*Platanthera leucophaea*). See additional sheets for details.



27. List any historic properties that have the potential to be affected by the proposed NWP activity or include a vicinity map indicating the location of the historic property or properties. (see instructions)  
See additional sheets for details.

28. For a proposed NWP activity that will occur in a component of the National Wild and Scenic River System, or in a river officially designated by Congress as a "study river" for possible inclusion in the system while the river is in an official study status, identify the Wild and Scenic River or the "study river":  
N/A

29. If the proposed NWP activity also requires permission from the Corps pursuant to 33 U.S.C. 408 because it will alter or temporarily or permanently occupy or use a U.S. Army Corps of Engineers federally authorized civil works project, have you submitted a written request for section 408 permission from the Corps district having jurisdiction over that project?  Yes  No  
If "yes", please provide the date your request was submitted to the Corps district:

30. If the terms of the NWP(s) you want to use require additional information to be included in the PCN, please include that information in this space or provide it on an additional sheet of paper marked Block 30. (see instructions)  
See additional sheets for details.

31. Pre-construction notification is hereby made for one or more nationwide permit(s) to authorize the work described in this notification. I certify that the information in this pre-construction notification is complete and accurate. I further certify that I possess the authority to undertake the work described herein or am acting as the duly authorized agent of the applicant.

 SIGNATURE OF APPLICANT	1-25-2024 DATE	 SIGNATURE OF AGENT	1/24/2024 DATE
---	-------------------	--	-------------------

The pre-construction notification must be signed by the person who desires to undertake the proposed activity (applicant) and, if the statement in Block 11 has been filled out and signed, the authorized agent.

18 U.S.C. Section 1001 provides that: Whoever, in any manner within the jurisdiction of any department or agency of the United States knowingly and willfully falsifies, conceals, or covers up any trick, scheme, or disguises a material fact or makes any false, fictitious or fraudulent statements or representations or makes or uses any false writing or document knowing same to contain any false, fictitious or fraudulent statements or entry, shall be fined not more than \$10,000 or imprisoned not more than five years or both.



**Instructions for Preparing a  
Department of the Army  
Nationwide Permit (NWP) Pre-Construction Notification (PCN)**

**Blocks 1 through 4.** To be completed by the Corps of Engineers.

**Block 5. Applicant's Name.** Enter the name and the e-mail address of the responsible party or parties. If the responsible party is an agency, company, corporation, or other organization, indicate the name of the organization and responsible officer and title. If more than one party is associated with the preconstruction notification, please attach a sheet of paper with the necessary information marked Block 5.

**Block 6. Address of Applicant.** Please provide the full address of the party or parties responsible for the PCN. If more space is needed, attach an extra sheet of paper marked Block 6.

**Block 7. Applicant's Telephone Number(s).** Please provide the telephone number where you can usually be reached during normal business hours.

**Blocks 8 through 11.** To be completed, if you choose to have an agent.

**Block 8. Authorized Agent's Name and Title.** Indicate name of individual or agency, designated by you, to represent you in this process. An agent can be an attorney, builder, contractor, engineer, consultant, or any other person or organization. Note: An agent is not required.

**Blocks 9 and 10. Agent's Address and Telephone Number.** Please provide the complete mailing address of the agent, along with the telephone number where he / she can be reached during normal business hours.

**Block 11. Statement of Authorization.** To be completed by the applicant, if an agent is to be employed.

**Block 12. Proposed Nationwide Permit Activity Name or Title.** Please provide a name identifying the proposed NWP activity, e.g., Windward Marina, Rolling Hills Subdivision, or Smith Commercial Center.

**Block 13. Name of Waterbody.** Please provide the name (if it has a name) of any stream, lake, marsh, or other waterway to be directly impacted by the NWP activity. If it is a minor (no name) stream, identify the waterbody the minor stream enters.

**Block 14. Proposed Activity Street Address.** If the proposed NWP activity is located at a site having a street address (not a box number), please enter it in Block 14.

**Block 15. Location of Proposed Activity.** Enter the latitude and longitude of where the proposed NWP activity is located. Indicate whether the project location provided is the center of the project or whether the project location is provided as the latitude and longitude for each of the "corners" of the project area requiring evaluation. If there are multiple sites, please list the latitude and longitude of each site (center or corners) on a separate sheet of paper and mark as Block 15.

**Block 16. Other Location Descriptions.** If available, provide the Tax Parcel Identification number of the site, Section, Township, and Range of the site (if known), and / or local Municipality where the site is located.

**Block 17. Directions to the Site.** Provide directions to the site from a known location or landmark. Include highway and street numbers as well as names. Also provide distances from known locations and any other information that would assist in locating the site. You may also provide a description of the location of the proposed NWP activity, such as lot numbers, tract numbers, or you may choose to locate the proposed NWP activity site from a known point (such as the right descending bank of Smith Creek, one mile downstream from the Highway 14 bridge). If a large river or stream, include the river mile of the proposed NWP activity site if known. If there are multiple locations, please indicate directions to each location on a separate sheet of paper and mark as Block 17.

**Block 18. Identify the Specific Nationwide Permit(s) You Propose to Use.** List the number(s) of the Nationwide Permit(s) you want to use to authorize the proposed activity (e.g., NWP 29).

**Block 19. Description of the Proposed Nationwide Permit Activity.** Describe the proposed NWP activity, including the direct and indirect adverse environmental effects the activity would cause. The description of the proposed activity should be sufficiently detailed to allow the district engineer to determine that the adverse environmental effects of the activity will be no more than minimal. Identify the materials to be used in construction, as well as the methods by which the work is to be done.

Provide sketches when necessary to show that the proposed NWP activity complies with the terms of the applicable NWP(s). Sketches usually clarify the activity and result in a quicker decision. Sketches should contain sufficient detail to provide an illustrative description of the proposed NWP activity (e.g., a conceptual plan), but do not need to be detailed engineering plans.

The written descriptions and illustrations are an important part of the application. Please describe, in detail, what you wish to do. If more space is needed, attach an extra sheet of paper marked Block 19.

**Block 20. Description of Proposed Mitigation Measures.** Describe any proposed mitigation measures intended to reduce the adverse environmental effects caused by the proposed NWP activity. The description of any proposed mitigation measures should be sufficiently detailed to allow the district engineer to determine that the adverse environmental effects of the activity will be no more than minimal and to determine the need for compensatory mitigation or additional mitigation measures.

**Block 21. Purpose of Nationwide Permit Activity.** Describe the purpose and need for the proposed NWP activity. What will it be used for and why? Also include a brief description of any related activities associated with the proposed project. Provide the approximate dates you plan to begin and complete all work.

**Block 22. Quantity of Wetlands, Streams, or Other Types of Waters Directly Affected by the Proposed Nationwide Permit Activity.** For discharges of dredged or fill material into waters of the United States, provide the amount of wetlands, streams, or other types of waters filled, flooded, excavated, or drained by the proposed NWP activity. For structures or work in navigable waters of the United States subject to Section 10 of the Rivers and Harbors Act of 1899, provide the amount of navigable waters filled, dredged, or occupied by one or more structures (e.g., aids to navigation, mooring buoys) by the proposed NWP activity.

For multiple NWPs, or for separate and distant crossings of waters of the United States authorized by NWPs 12 or 14, attach an extra sheet of paper marked Block 21 to provide the quantities of wetlands, streams, or other types of waters filled, flooded, excavated, or drained (or dredged or occupied by structures, if in waters subject to Section 10 of the Rivers and Harbors Act of 1899) for each NWP. For NWPs 12 and 14, include the amount of wetlands, streams, or other types of waters filled, flooded, excavated, or drained for each separate and distant crossing of waters or wetlands. If more space is needed, attach an extra sheet of paper marked Block 22.

**Block 23. Identify Any Other Nationwide Permit(s), Regional General Permit(s), or Individual Permit(s) Used to Authorize Any Part of Proposed Activity or Any Related Activity.** List any other NWP(s), regional general permit(s), or individual permit(s) used or intended to be used to authorize any part of the proposed project or any related activity. For linear projects, list other separate and distant crossings of waters and wetlands authorized by NWPs 12 or 14 that do not require PCNs. If more space is needed, attach an extra sheet of paper marked Block 23.

**Block 24. Compensatory Mitigation Statement for Losses of Greater Than 1/10-Acre of Wetlands When Pre-Construction Notification is Required.** Paragraph (c) of NWP general condition 23 requires compensatory mitigation at a minimum one-for-one replacement ratio will be required for all wetland losses that exceed 1/10-acre and require pre-construction notification, unless the district engineer determines in writing that either some other form of mitigation is more environmentally appropriate or the adverse environmental effects of the proposed NWP activity are no more than minimal without compensatory mitigation, and provides an activity-specific waiver of this requirement. Describe the proposed compensatory mitigation for wetland losses greater than 1/10 acre, or provide an explanation of why the district engineer should not require wetland compensatory mitigation for the proposed NWP activity. If more space is needed, attach an extra sheet of paper marked Block 24.

**Block 25. Is Any Portion of the Nationwide Permit Activity Already Complete?** Describe any work that has already been completed for the NWP activity.

**Block 26. List the Name(s) of Any Species Listed As Endangered or Threatened under the Endangered Species Act that Might be Affected by the Nationwide Permit Activity.** If you are not a federal agency, and if any listed species or designated critical habitat might be affected or is in the vicinity of the proposed NWP activity, or if the proposed NWP activity is located in designated critical habitat, list the name(s) of those endangered or threatened species that might be affected by the proposed NWP activity or utilize the designated critical habitat that might be affected by the proposed NWP activity. If you are a Federal agency, and the proposed NWP activity requires a PCN, you must provide documentation demonstrating compliance with Section 7 of the Endangered Species Act.

**Block 27. List Any Historic Properties that Have the Potential to be Affected by the Nationwide Permit Activity.** If you are not a Federal agency, and if any historic properties have the potential to be affected by the proposed NWP activity, list the name(s) of those historic properties that have the potential to be affected by the proposed NWP activity. If you are a Federal agency, and the proposed NWP activity requires a PCN, you must provide documentation demonstrating compliance with Section 106 of the National Historic Preservation Act.

**Block 28. List the Wild and Scenic River or Congressionally Designated Study River if the Nationwide Permit Activity Would Occur in such a River.** If the proposed NWP activity will occur in a river in the National Wild and Scenic River System or in a river officially designated by Congress as a "study river" under the Wild and Scenic Rivers Act, provide the name of the river. For a list of Wild and Scenic Rivers and study rivers, please visit <http://www.rivers.gov/>.

**Block 29. Nationwide Permit Activities that also Require Permission from the Corps Under 33 U.S.C. 408.** If the proposed NWP activity also requires permission from the Corps under 33 U.S.C. 408 because it will temporarily or permanently alter, occupy, or use a Corps federal authorized civil works project, indicate whether you have submitted a written request for section 408 permission from the Corps district having jurisdiction over that project.

**Block 30. Other Information Required For Nationwide Permit Pre-Construction Notifications.** The terms of some of the Nationwide Permits include additional information requirements for preconstruction notifications:

- \* NWP 3, Maintenance –information regarding the original design capacities and configurations of the outfalls, intakes, small impoundments, and canals.
- \* NWP 31, Maintenance of Existing Flood Control Facilities –a description of the maintenance baseline and the dredged material disposal site.
- \* NWP 33, Temporary Construction, Access, and Dewatering –a restoration plan showing how all temporary fills and structures will be removed and the area restored to pre-project conditions.
- \* NWP 44, Mining Activities –if reclamation is required by other statutes, then a copy of the final reclamation plan must be submitted with the pre-construction notification.
- \* NWP 45, Repair of Uplands Damaged by Discrete Events –documentation, such as a recent topographic survey or photographs, to justify the extent of the proposed restoration.
- \* NWP 48, Commercial Shellfish Aquaculture Activities –(1) a map showing the boundaries of the project area, with latitude and longitude coordinates for each corner of the project area; (2) the name(s) of the species that will be cultivated during the period this NWP is in effect; (3) whether canopy predator nets will be used; (4) whether suspended cultivation techniques will be used; and (5) general water depths in the project area (a detailed survey is not required).
- \* NWP 49, Coal Remining Activities –a document describing how the overall mining plan will result in a net increase in aquatic resource functions must be submitted to the district engineer and receive written authorization prior to commencing the activity.
- \* NWP 50, Underground Coal Mining Activities –if reclamation is required by other statutes, then a copy of the reclamation plan must be submitted with the pre-construction notification.

If more space is needed, attach an extra sheet of paper marked Block 30.

**Block 31. Signature of Applicant or Agent.** The PCN must be signed by the person proposing to undertake the NWP activity, and if applicable, the authorized party (agent) that prepared the PCN. The signature of the person proposing to undertake the NWP activity shall be an affirmation that the party submitting the PCN possesses the requisite property rights to undertake the NWP activity (including compliance with special conditions, mitigation, etc.).

#### **DELINEATION OF WETLANDS, OTHER SPECIAL AQUATIC SITES, AND OTHER WATERS**

Each PCN must include a delineation of wetlands, other special aquatic sites, and other waters, such as lakes and ponds, and perennial, intermittent, and ephemeral streams, on the project site. Wetland delineations must be prepared in accordance with the current wetland delineation manual and regional supplement published by the Corps. The permittee may ask the Corps to delineate the special aquatic sites and other waters on the project site, but there may be a delay if the Corps does the delineation, especially if the project site is large or contains many wetlands, other special aquatic sites, and other waters. The 45 day PCN review period will not start until the delineation is submitted or has been completed by the Corps.

#### **DRAWINGS AND ILLUSTRATIONS**

##### **General Information.**

Three types of illustrations are needed to properly depict the work to be undertaken. These illustrations or drawings are identified as a Vicinity Map, a Plan View or a Typical Cross-Section Map. Identify each illustration with a figure or attachment number. For linear projects (e.g. roads, subsurface utility lines, etc.) gradient drawings should also be included. Please submit one original, or good quality copy, of all drawings on 8½x11 inch plain white paper (electronic media may be substituted). Use the fewest number of sheets necessary for your drawings or illustrations. Each illustration should identify the project, the applicant, and the type of illustration (vicinity map, plan view, or cross-section). While illustrations need not be professional (many small, private project illustrations are prepared by hand), they should be clear, accurate, and contain all necessary information.

#### **ADDITIONAL INFORMATION AND REQUIREMENTS**

For proposed NWP activities that involve discharges into waters of the United States, water quality certification from the State, Tribe, or EPA must be obtained or waived (see NWP general condition 25). Some States, Tribes, or EPA have issued water quality certification for one or more NWPs. Please check the appropriate Corps district web site to see if water quality certification has already been issued for the NWP(s) you wish to use. For proposed NWP activities in coastal states, state Coastal Zone Management Act consistency concurrence must be obtained, or a presumption of concurrence must occur (see NWP general condition 26). Some States have issued Coastal Zone Management Act consistency concurrences for one or more NWPs. Please check the appropriate Corps district web site to see if Coastal Zone Management Act consistency concurrence has already been issued for the NWP(s) you wish to use.



**Preconstruction Notification for Nationwide Permit #12 – Oil or Natural Gas Pipeline Activities**

**The East Ohio Gas Company, d/b/a Dominion Energy Ohio, Pipeline Infrastructure Replacement (PIR) Program**

**PIR 2788 – Apple Creek  
Wooster Township, Wayne County, Ohio**

**Application Eng Form 6082: Additional Information**

**BLOCK 19– Description of the Proposed Nationwide Permit Activity**

The PIR 2788 project is located along the road right-of-way (ROW) of N. Hillcrest Drive, an existing sixty (60)-ft wide utility easement which originates at N. Hillcrest Drive and extends northeast to S. Geyers Chapel Road, and a newly acquired sixty (60)-foot wide easement which originates as a private drive on the east side of N. Hillcrest Drive and extends east to Apple Creek.

Project maps showing the pipeline sections to be replaced and relocated are provided in Attachment A. The pipeline activities will occur within a ten (10)-foot construction corridor within the road right-of-way (ROW) along N. Hillcrest Drive as well as a sixty (60)-foot wide easement through the newly acquired utility easement, and existing utility easement area northeast of Apple Creek. The construction activities will require soil disturbance within road ROW and the easement to accommodate areas for trench excavation, side-cast spoil storage, and temporary storage of the new and removed pipe. All work shall be performed within authorized limits of disturbance. The existing pipeline within the existing easement southwest of Apple Creek will be abandoned and minor excavation is expected to perform abandonment work. The replacement pipeline will be installed in a portion of the existing easement, in the newly acquired easement, and along road ROW.

Installation of the replacement and relocated pipeline cannot occur without temporary discharge into waters of the United States, although construction activities have been adjusted to the maximum extent practicable to avoid and minimize impacts to water resources. The reason for the temporary discharge into these water resources is to allow for the construction activities necessary to safely replace and install the pipeline within the utility easements and/or road ROW. The construction activities involve the temporary excavation of a trench and placement of discharged, excavated material through Stream 1 (Apple Creek), Stream 4, Stream 5, Stream 6, and Wetland A. Stream 2 will also be temporarily impacted for the installation of a temporary 40-ft wide culvert crossing for construction equipment. Additional disturbance may result from equipment use within the ten (10)-foot wide and sixty (60)-foot wide construction corridor in wetland and stream crossings. The project impacts are temporary and will not result in any permanent loss of stream length or wetland area; however, a portion of Wetland A will experience a permanent change in vegetation type, from Forested to Emergent. No permanent relocation of wetlands or water bodies is planned. There will be no permanent changes in grade, ground surface material, waterway drainage, or wetland contours, as all areas disturbed by the project will be restored to pre-construction condition. However, rip-rap may be necessary for stream bank stabilization.

A trench will be excavated to remove the old pipeline and to allow sufficient cover over the new pipeline after installation and backfilling. Within smaller streams which may be flowing, a pump around concept is used to allow for work to occur in dry conditions. In larger streams, a temporary flume is placed within streams, the trench will be excavated within the dry stream channel to replace the pipeline. Separation of the topsoil from the subsoil will be performed at water bodies, residential properties, and agricultural lands. The backfill material that will be returned to the trench will consist of the same material removed from the trench, to the extent practicable. Rip-rap may be used for banks stabilization as deemed necessary. Excess soil will be spread onsite, with the exception of agricultural land, wetlands, floodplains, streams, drainage ways, or other environmentally sensitive areas. Following pipeline installation, all disturbed areas will be returned to their original slope and contour, stabilized, and seeded. However, typically wetlands will not be seeded as the existing seedbank will provide for natural re-vegetation. These efforts will provide a permanent herbaceous cover to stabilize the disturbed soils. Temporary erosion controls will be maintained until this permanent cover is established.

New impervious surfaces will not be created. Areas that will be affected are located within the easement corridors and/or road ROW. Tree cutting will be necessary in forested portions of Wetland A.

## **BLOCK 20 – Description of Proposed Mitigation Measures**

Impacts to wetlands and streams within the project area have been minimized to the greatest extent practicable. Impacted forested wetlands will be restored as emergent wetlands. Stream 3 is avoided by the proposed project. This feature will be flagged and avoided during construction activity.

The physical disturbance of forested wetland soils will be confined to the sixty (60)-ft wide easement through forested portions of Wetland A. This will result in a total of 0.482 acres of permanent conversion to Category 2 forested wetlands for the Project. Due to the conversion within Wetland A, DEO proposes to purchase 0.80 credits (utilizing a ration of 1.5:1 for PFO impacts) from The Nature Conservancy's In-Lieu Fee program. See Table 3 for itemization of wetland impacts and mitigation.

Project construction activities (e.g., mowing/clearing, grading, trench excavation, spoil storage, backfilling, and restoration) will expose bare soils and increase the potential for erosion and sedimentation. Best Management Practices (BMPs) will be implemented throughout construction to minimize storm water runoff, soil erosion, the transport of sediments from the construction area, and to protect surface waters and wetlands located in and adjacent to the project area. Construction details are included in Attachment C.

Additionally, DEO contractors will comply with BMPs for work in wetlands and water bodies, including NWP provisions and Specific Regional Conditions as follows:

- If material from trench excavation is sidecast into waters of the United States, it will be placed so that it is not dispersed by currents or other forces and it will be backfilled or removed in less than three (3) months.

- In wetlands, the top six (6) to twelve (12) inches of the trench should normally be backfilled with topsoil from the trench. The trench will be backfilled in such a manner as to avoid draining waters of the United States.
- DEO will use existing access routes, the existing DEO gas line easement, and the newly acquired gas line easement for access to the project area. Use of access roads will be limited to the minimum width necessary.
- Equipment traveling across water bodies and wetlands along the easement access routes will use mats or bridges across the ground/resource as needed to protect the resource from unnecessary disturbance. These mats or bridges will be removed upon completion of the construction work. All access roads used solely for construction of the utility line will be removed upon completion of the work.
- Temporary fills must consist of materials, and be placed in a manner, that will not be eroded by expected high flows.
- Appropriate measures must be taken to maintain normal downstream flows and minimize flooding to the maximum extent practicable.
- Exposed slopes and stream banks will be stabilized immediately upon completion of the work at each water body.

## **BLOCK 22 – Quantity of Wetlands, Streams, or Other Types of Waters Directly Affected by the Proposed Nationwide Permit Activity**

The type and amount of material to be discharged is associated with excavation of the trench within Wetland A and Streams 1 (Apple Creek), 4, 5, and 6. Disturbed soils will be replaced within the trench after the new pipe is installed. The backfill material that will be returned to the trench will consist of the same material removed from the trench, to the extent practicable. Separation of the topsoil from the subsoil will be performed at wetlands, residential properties, and agricultural lands. Streambed substrate will be separated from the subsoil and backfilled last to restore preconstruction conditions. The use of rip-rap may be necessary at stream crossings to stabilize stream banks. The soils within the project area are identified in the attached Aquatic Resources Delineation Report (Attachment B; Appendix A).

Impacts from excavation to install the pipeline include temporary disturbance of Wetland A, Streams 1 (Apple Creek), 2, 4, and 5. The proposed project will cross through three (3) ephemeral streams, one (1) intermittent stream, one (1) perennial stream, and one (1) wetland with a maximum disturbance width of sixty (60) feet as illustrated on the Project Maps in Attachment A. A total of 183 linear feet of streams (65 feet bank-to-bank, 0.0040 acre) and 1.124 acre of wetland will be temporarily impacted, however, use of rip-rap may be deemed necessary. See Tables 1 and 2 for itemization of wetland and stream impacts. Photographs of the streams and wetlands are included in the attached Aquatic Resources Delineation Report (Attachment B, Appendix D).

The proposed pipeline relocation activities are within the Special Flood Hazard Area (100-year floodplain) of Stream 1 (Apple Creek), as shown on the *FEMA Floodplains Map* (Attachment B, Appendix A). Because construction will occur within the floodplain, a floodplain permit



will be obtained from Wayne County prior to construction. No permanent fill will occur within the 100-year floodplain of Stream 1 and best management practices will be utilized to minimize impacts to the floodplain. However, as noted, rip-rap may be necessary for bank stabilization over the pipeline trench.

### **BLOCK 23 – Other NWP, Regional General Permits, or Individual Permits**

#### **Ohio EPA Water Quality Certification Eligibility**

The Ohio EPA has waived its right for conditioning the Water Quality Certifications (WQCs) for the reissued 2021 NWPs, which include NWP 12. As such WQC is considered granted with the NWP authorization and separate coordination with the Ohio EPA is not required.

### **BLOCK 24 – Compensatory Mitigation**

The proposed activities will result in a permanent conversion of forested wetland to emergent wetland, due to construction activities and the maintenance of woody vegetation within the easement. A total of 0.002 acre of scrub/shrub and 0.482 acre of forested wetlands will be converted to emergent wetlands. Due to the conversion within these wetlands, DEO proposes the purchase of 0.80 credits (utilizing a ratio of 1.5:1 for PFO impacts) from The Nature Conservancy's In-Lieu Fee program. See Table 3 for itemization of wetland impacts and mitigation.

### **BLOCK 26 – Threatened and Endangered Species**

The project area was reviewed for trees that could provide habitat for the federally endangered Indiana bat (*Myotis sodalis*), the federally endangered northern long-eared bat (*M. septentrionalis*), and the federally proposed as endangered tricolored bat (*Perimyotis subflavus*). Eleven (11) trees were identified within or near the project area with characteristics which may potentially provide habitat for these bats. The locations of these trees are indicated in Attachment A. Additionally, a forested corridor along Apple Creek is located within the project. Because of this, DEO proposes to cut all trees between October 1 and March 31.

A mussel survey was conducted in Apple Creek on September 16, 2023. The survey did not identify any mussel species within the section of Apple Creek proposed for construction.

Habitat for the federally threatened eastern prairie fringed orchid (*Platanthera leucophaea*) and the federal candidate monarch butterfly (*Danaus plexippus*) is not located within the project area.

DEO initiated coordination with the U.S. Fish & Wildlife Service (USFWS) on January 23, 2024. On January 26, 2024 the USFWS service responded that adverse impacts to federally listed bats are not anticipated due to the implementation of seasonal tree clearing. Additionally, USFWS does not anticipate adverse effects to any other federally endangered, threatened, or proposed species, or proposed or designated critical habitat. See Attachment D.

DEO initiated coordination with the Ohio Department of Natural Resources (ODNR) on March

26, 2021. Coordination regarding threatened and endangered species is included in Attachment D. On May 25, 2021 ODNR responded that there are no records of state endangered or threatened plants or animals within the project area. Additionally, there are no records of state potentially threatened plants, special interest or species of concern animals, or any federally listed species. However, a mussel survey was required and completed within Apple Creek. (See Attachment D)

In addition, due to modifications in the project layout, ODNR coordination is the the process of being re initiated with the agency.

### **BLOCK 27 – OHPO Historic Records**

A review of the Ohio Historical Preservation Office (OHPO) data records for National Register Listed Properties, Archaeological Inventory Properties, Historic Inventory Properties, National Register Listed Districts, and Phases 1–3 Survey Areas was done for the PIR 2788 – Apple Creek project area and areas immediately adjacent. No National Registered listed structures, properties, or districts were identified within or immediately adjacent to the project area.

A previous Phase 2 Archaeological Survey was conducted within southern portions of the PIR 2788 study area for the proposed Route U.S. 30 widening corridor from November 1993 until July 1994. A total of 297 Archaeological Sites were identified during the survey, but none of these identified sites are located within or immediately adjacent to the project area.

One (1) previously recorded OAI Archaeological Site, the Taggart Farm site (WE0085), overlaps most of the study area north of Apple Creek and is designated based on its historic affiliation. The exact location of the site is unknown, and the site boundary as shown on the Historical and Cultural Resources Map (Attachment E) is approximated by OHPO. The site is currently under agricultural use and has likely been disturbed by plowing.

OHPO Section 106 Coordination has been initiated and results will be provided upon receipt of the impact determination.

A map of the project area showing the location of the Phase 2 Survey Area and OAI site is included in Attachment E.

**Table 1. Wetland Impact Analysis Table.**

<i>Wetland</i>	<i>Cowardin Classification</i>	<i>ORAM Category</i>	<i>Within Review Area</i>	<i>Within Construction Corridor</i>			
			<i>Area (ac)</i>	<i>Impact<sup>1</sup> Area (ac)</i>	<i>Trench Crossing Length (lf)</i>	<i>Trench Crossing Area (ac)</i>	<i>Amount of Discharge (cu yd)<sup>2</sup></i>
A	PEM, PSS. PFO	2	2.490	1.124	816	0.056	498.7

<sup>1</sup> All impacts will be temporary and all grades will be restored to pre-construction contours.

<sup>2</sup> Discharge associated with trench excavation.



**Table 2. Stream Impact Analysis Table.**

<i>Stream</i>	<i>Flow Regime</i>	<i>OHWL Width (ft)</i>	<i>Within Review Area</i>		<i>Within Construction Corridor</i>			
			<i>Length (lf)</i>	<i>Area (ac)</i>	<i>Upstream to Downstream Length (lf)</i>	<i>Trench Crossing Length (lf)</i>	<i>Trench Impact Area (ac)<sup>1</sup></i>	<i>Amount of Discharge (cu yd)<sup>2</sup></i>
1 (Apple Creek)	Perennial	48	180	0.198	52	48	0.0033	29.3
2	Ephemeral	2	155	0.007	68	0 <sup>3</sup>	0.0000	0.0
3	Ephemeral	6	83	0.011	0	0	0.0000	0.0
4	Intermittent	9	93	0.019	44	9	0.0006	5.5
5	Ephemeral	4	83	0.008	9	4	0.0003	2.4
6	Ephemeral	4	673	0.062	10	4	0.0003	2.4
<b>Total</b>	--	--	<b>1,267</b>	<b>0.306</b>	<b>183</b>	<b>65</b>	<b>0.0040</b>	<b>39.7</b>

<sup>1</sup> All impacts will be temporary and all grades will be restored to preconstruction contours.

<sup>2</sup> Discharge associated with trench excavation.

<sup>3</sup> Impacts to Stream 2 will involve the installation of a temporary culvert for equipment access and will not involve trenching.

**Table 3. Mitigation Analysis Table.**

<i>Wetland</i>	<i>Cowardin Classification of Converted Wetland Area</i>	<i>ORAM Category</i>	<i>Within Review Area</i>	<i>Within Construction Corridor</i>		<i>Mitigation Ratio</i>	<i>Offsite Mitigation Required</i>
			<i>PFO<sup>1</sup>/PSS<sup>2</sup> Area (ac)</i>	<i>Crossing Width (ft)</i>	<i>Area of Permanent Conversion (ac)</i>		
A	PSS	2	0.220	10	0.002	- <sup>3</sup>	0.000
	PFO		1.540	60	0.482	1.5 <sup>4</sup>	0.723
<b>Total</b>	--	--	<b>1.760</b>	-	<b>0.484</b>	-	<b>0.723</b>

<sup>1</sup> Palustrine Forested

<sup>2</sup> Palustrine Scrub- Shrub

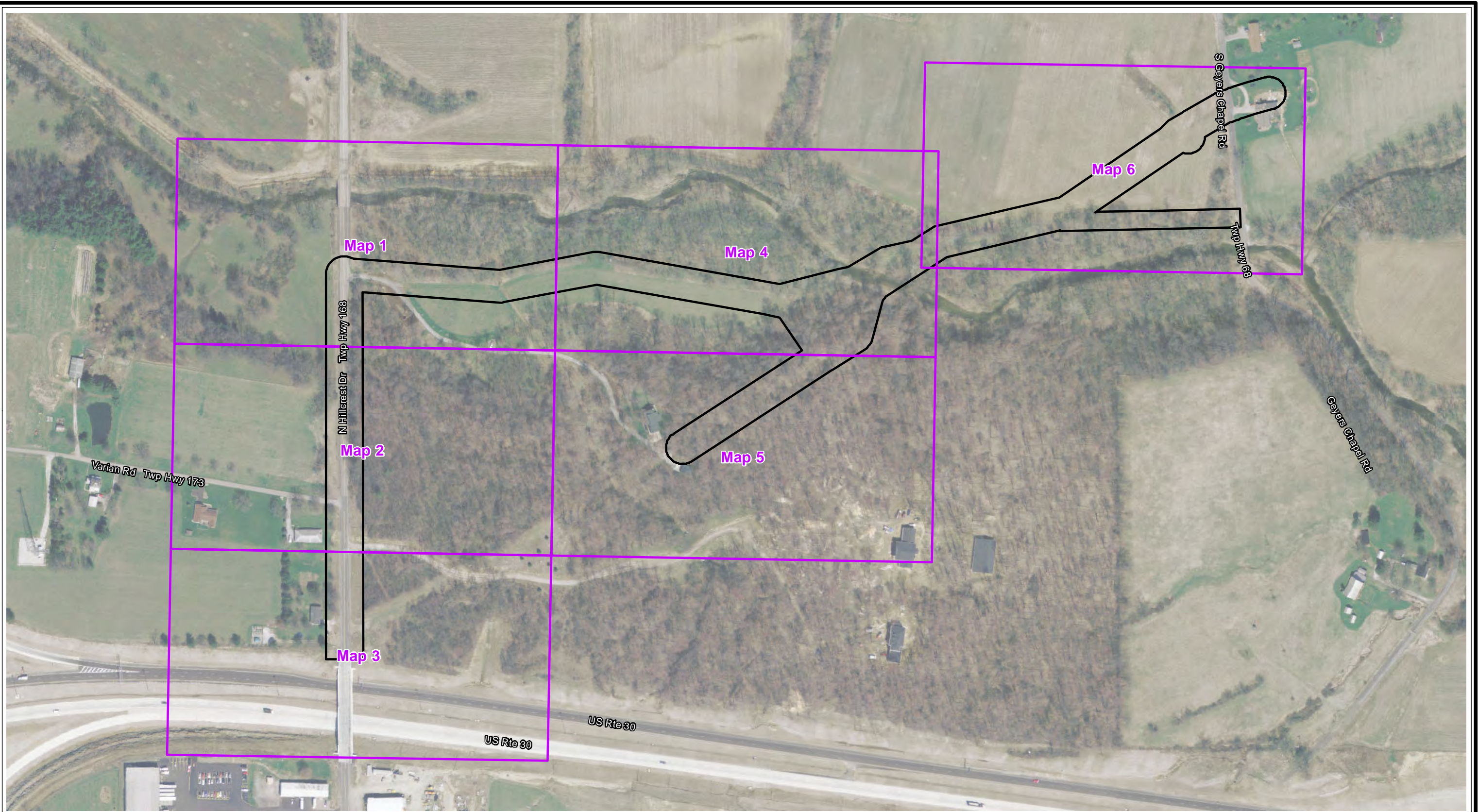
<sup>3</sup> No mitigation is proposed for each single and complete linear project/crossing with <0.1 ac of cumulative permanent conversion of PFO or PSS wetlands.



<sup>4</sup> DEO assumes that a mitigation ration of 1:1 is satisfied through restoration of impacted PFO to PEM. Proposed mitigation satisfies the remainder of ratios following Ohio Administrative Code 3745-1-54.

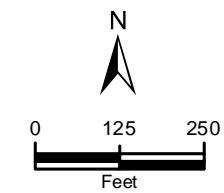
**Attachment A**

Project Site Plan Maps





 Project Study Area  
 Map Extent



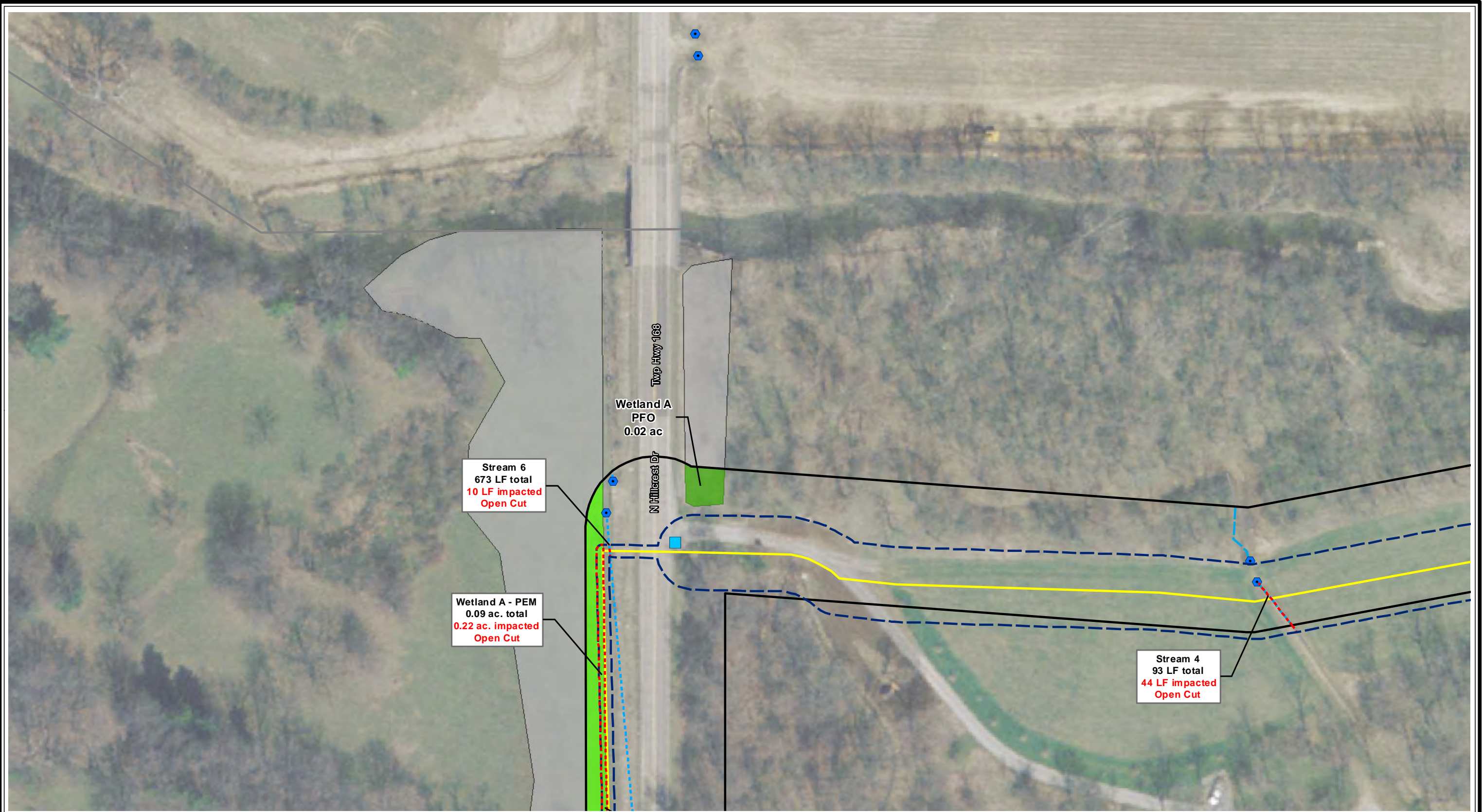
Base Layer: OSIP 2016

**Figure 1**  
**Impacts Map Book**

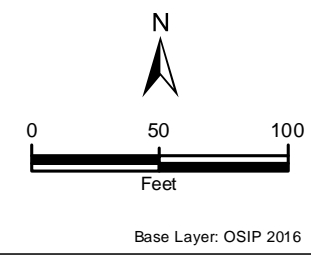
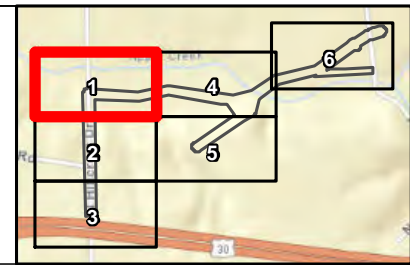
PIR 2788 - Apple Creek  
 Dominion Energy Ohio  
 Wayne County, Ohio  
 Date: 1/17/2024








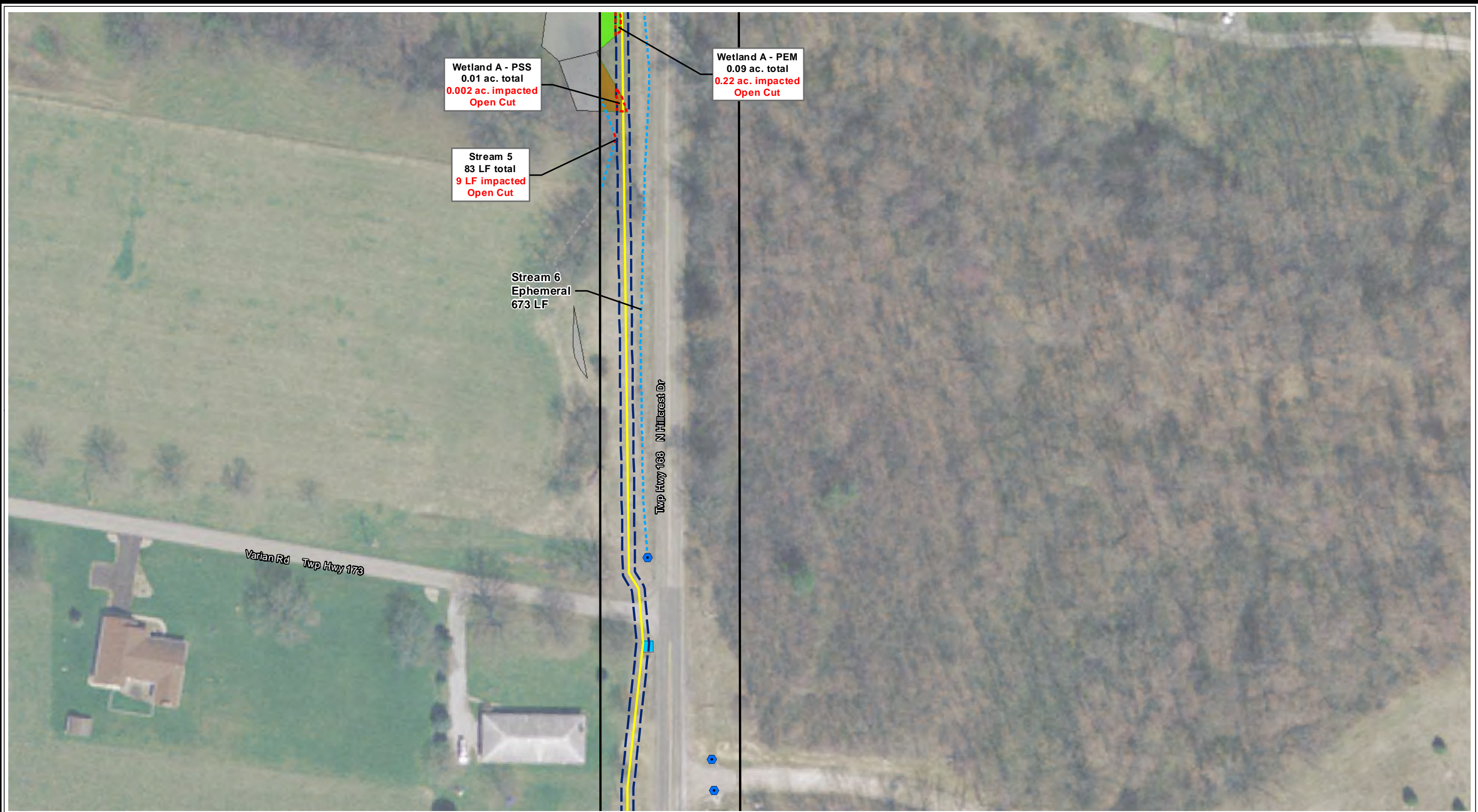
- |                    |                              |                             |                               |
|--------------------|------------------------------|-----------------------------|-------------------------------|
| Project Study Area | Potential Roost Tree         | Off-site Ephemeral Stream   | <b>Flood Zones (FEMA)</b>     |
| Work Corridor      | Delineated Stream            | Delineated Wetlands         | 1% Annual Chance Flood Hazard |
| Proposed Pipeline  | On-site Perennial Stream     | On-site Emergent Wetland    | Regulatory Floodway           |
| Stream Impact      | Off-site Perennial Stream    | On-site Forested Wetland    |                               |
| Wetland Impact     | On-site Intermittent Stream  | On-site Shrub Scrub Wetland |                               |
| Stormwater Inlet   | Off-site Intermittent Stream | Off-Site Wetland            |                               |
| Culvert            | On-site Ephemeral Stream     |                             |                               |



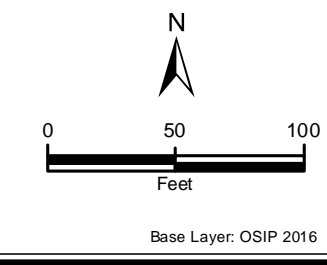
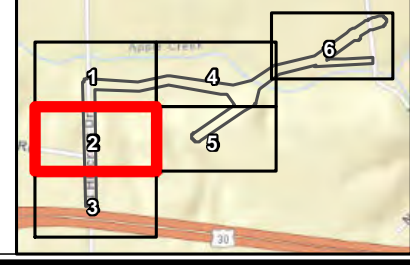
**Figure 1**  
**Impacts Map 1 of 6**  
 PIR 2788 - Apple Creek  
 Dominion Energy Ohio  
 Wayne County, Ohio  
 Date: 1/17/2024





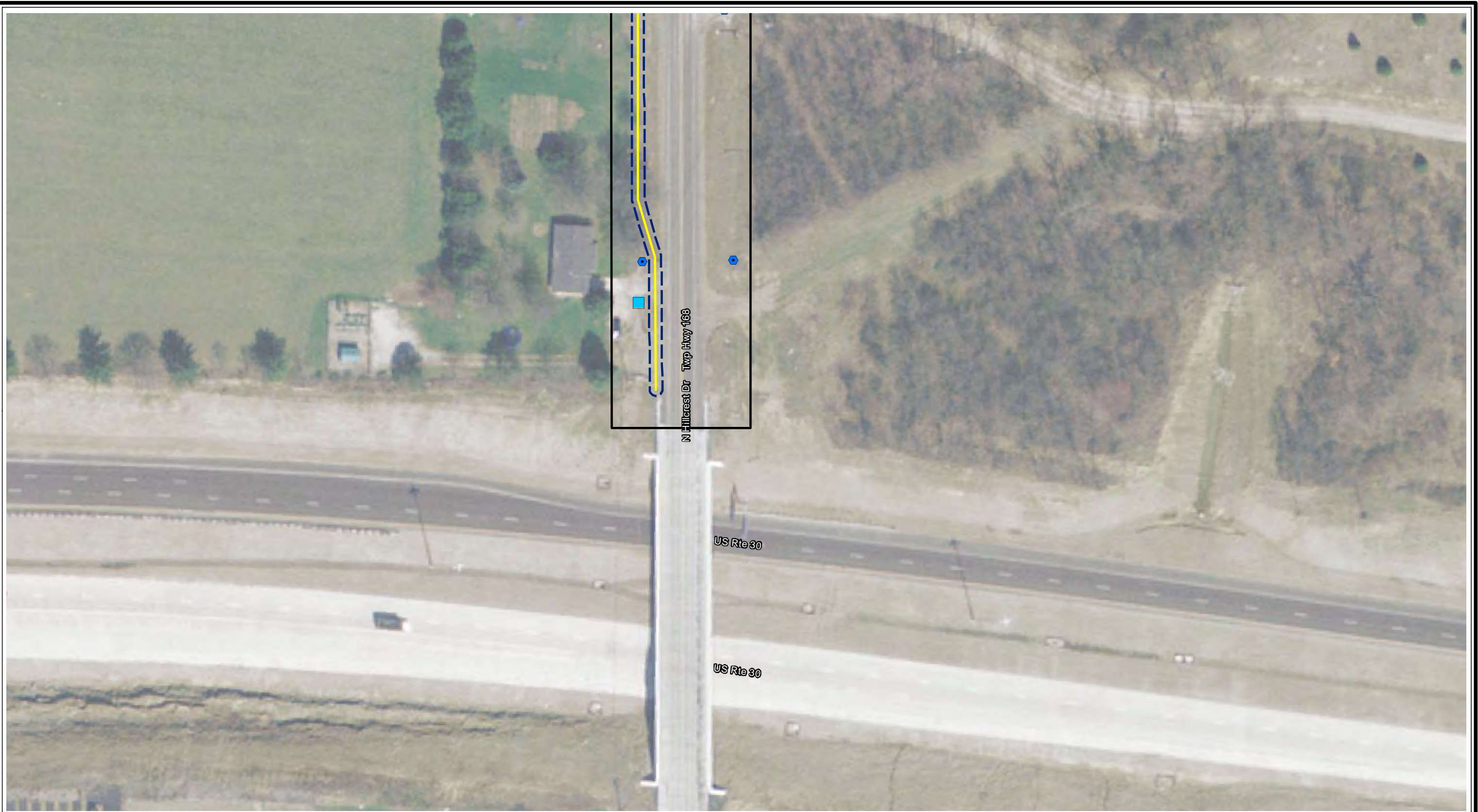


- |                    |                              |                             |                               |
|--------------------|------------------------------|-----------------------------|-------------------------------|
| Project Study Area | Potential Roost Tree         | Off-site Ephemeral Stream   | <b>Flood Zones (FEMA)</b>     |
| Work Corridor      | Delineated Stream            | Delineated Wetlands         | 1% Annual Chance Flood Hazard |
| Proposed Pipeline  | On-site Perennial Stream     | On-site Emergent Wetland    | Regulatory Floodway           |
| Stream Impact      | Off-site Perennial Stream    | On-site Forested Wetland    |                               |
| Wetland Impact     | On-site Intermittent Stream  | On-site Shrub Scrub Wetland |                               |
| Stormwater Inlet   | Off-site Intermittent Stream | Off-Site Wetland            |                               |
| Culvert            | On-site Ephemeral Stream     |                             |                               |

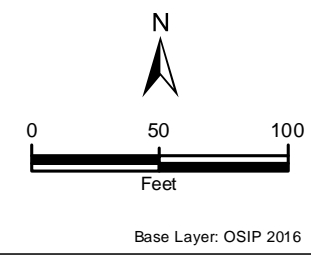
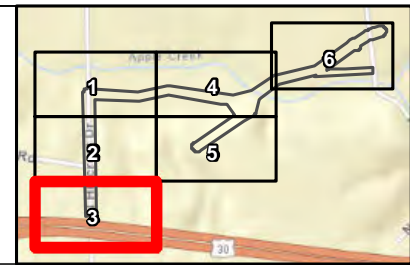


**Figure 1**  
**Impacts Map 2 of 6**  
 PIR 2788 - Apple Creek  
 Dominion Energy Ohio  
 Wayne County, Ohio  
 Date: 1/17/2024





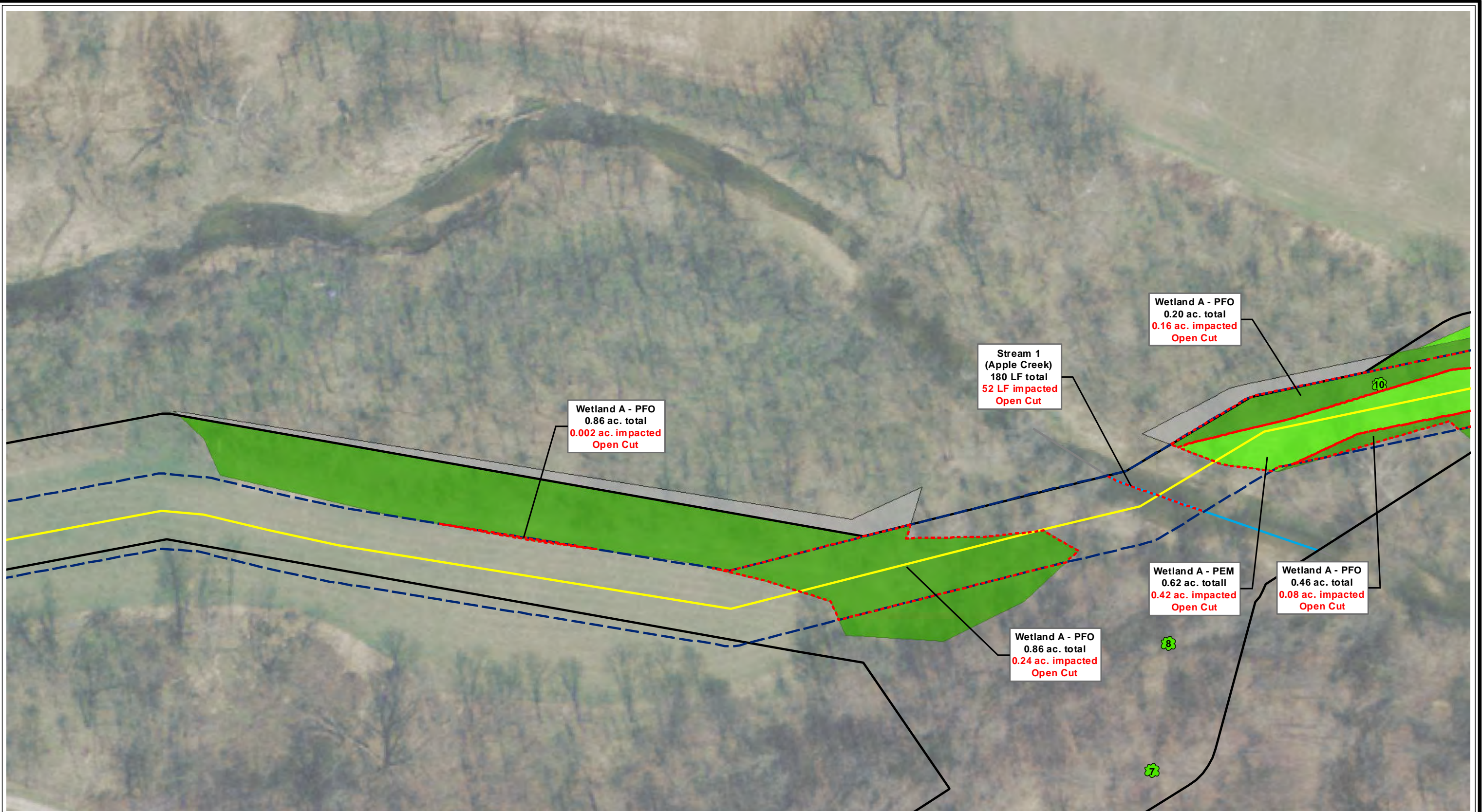
- |                    |                              |                             |                               |
|--------------------|------------------------------|-----------------------------|-------------------------------|
| Project Study Area | Potential Roost Tree         | Off-site Ephemeral Stream   | Flood Zones (FEMA)            |
| Work Corridor      | Delineated Stream            | Delineated Wetlands         | 1% Annual Chance Flood Hazard |
| Proposed Pipeline  | On-site Perennial Stream     | On-site Emergent Wetland    | Regulatory Floodway           |
| Stream Impact      | Off-site Perennial Stream    | On-site Forested Wetland    |                               |
| Wetland Impact     | On-site Intermittent Stream  | On-site Shrub Scrub Wetland |                               |
| Stormwater Inlet   | Off-site Intermittent Stream | Off-Site Wetland            |                               |
| Culvert            | On-site Ephemeral Stream     |                             |                               |



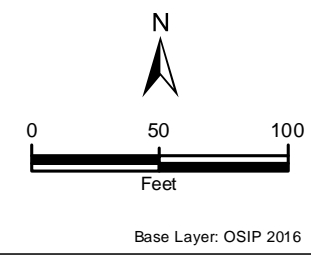
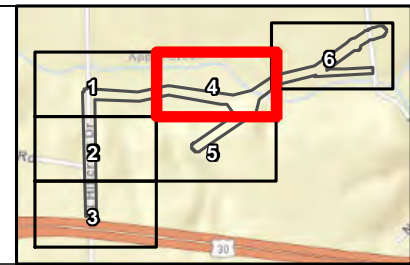
**Figure 1**  
**Impacts Map 3 of 6**  
 PIR 2788 - Apple Creek  
 Dominion Energy Ohio  
 Wayne County, Ohio  
 Date: 1/17/2024








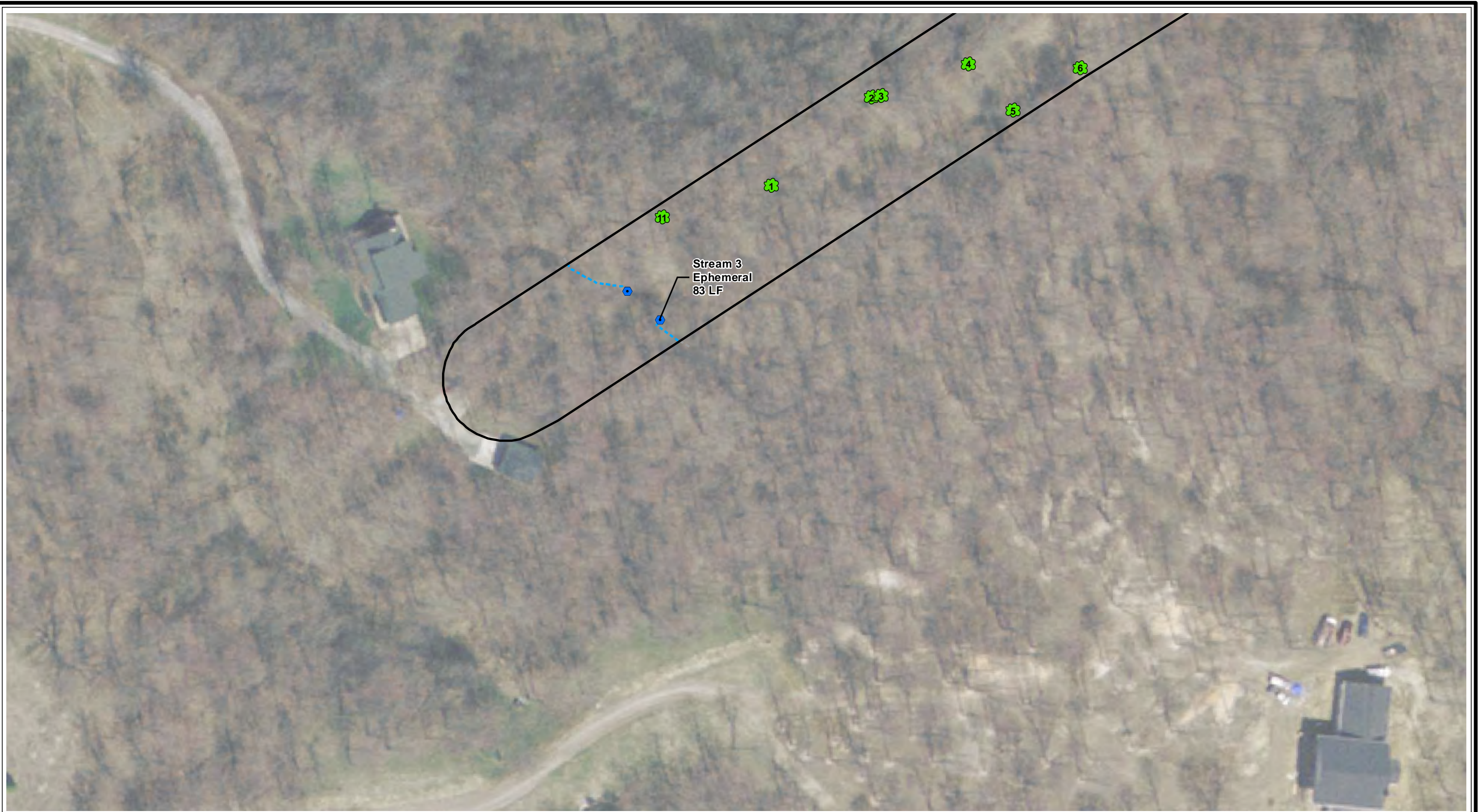
Project Study Area	Potential Roost Tree	Off-site Ephemeral Stream	<b>Flood Zones (FEMA)</b>
Work Corridor	Delineated Stream	Delineated Wetlands	1% Annual Chance Flood Hazard
Proposed Pipeline	On-site Perennial Stream	On-site Emergent Wetland	Regulatory Floodway
Stream Impact	Off-site Perennial Stream	On-site Forested Wetland	
Wetland Impact	On-site Intermittent Stream	On-site Shrub Scrub Wetland	
Stormwater Inlet	Off-site Intermittent Stream	Off-Site Wetland	
Culvert	On-site Ephemeral Stream		



**Figure 1**  
**Impacts Map 4 of 6**  
 PIR 2788 - Apple Creek  
 Dominion Energy Ohio  
 Wayne County, Ohio  
 Date: 1/17/2024

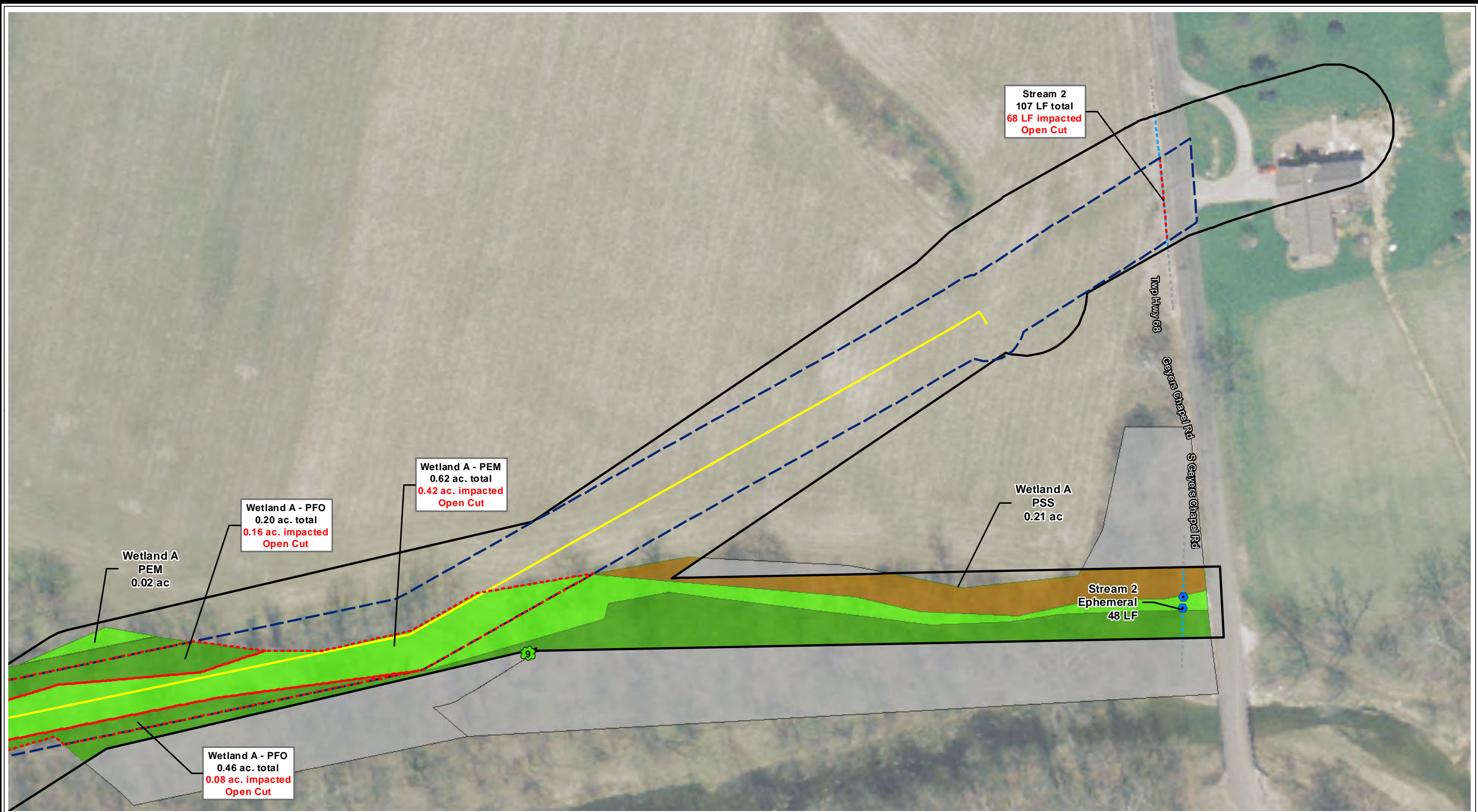




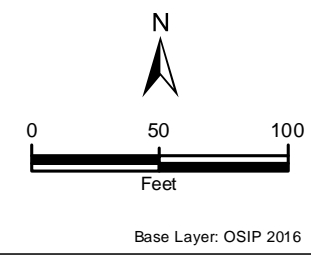
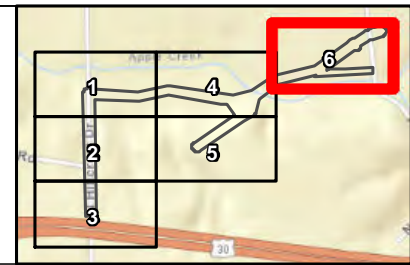


<ul style="list-style-type: none"> <li> Project Study Area</li> <li> Work Corridor</li> <li> Proposed Pipeline</li> <li> Stream Impact</li> <li> Wetland Impact</li> <li> Stormwater Inlet</li> <li> Culvert</li> </ul>	<ul style="list-style-type: none"> <li> Potential Roost Tree</li> <li> Delineated Stream</li> <li> On-site Perennial Stream</li> <li> Off-site Perennial Stream</li> <li> On-site Intermittent Stream</li> <li> Off-site Intermittent Stream</li> <li> On-site Ephemeral Stream</li> </ul>	<ul style="list-style-type: none"> <li> Off-site Ephemeral Stream</li> <li> Delineated Wetlands</li> <li> On-site Emergent Wetland</li> <li> On-site Forested Wetland</li> <li> On-site Shrub Scrub Wetland</li> <li> Off-Site Wetland</li> </ul>	<ul style="list-style-type: none"> <li> Flood Zones (FEMA)</li> <li> 1% Annual Chance Flood Hazard</li> <li> Regulatory Floodway</li> </ul>		<p>Base Layer: OSIP 2016</p>	<p><b>Figure 1</b>  <b>Impacts Map 5 of 6</b>          PIR 2788 - Apple Creek          Dominion Energy Ohio          Wayne County, Ohio          Date: 1/17/2024</p>
---	--	---	---	--	------------------------------	--






- |                    |                              |                             |                               |
|--------------------|------------------------------|-----------------------------|-------------------------------|
| Project Study Area | Potential Roost Tree         | Off-site Ephemeral Stream   | <b>Flood Zones (FEMA)</b>     |
| Work Corridor      | Delineated Stream            | Delineated Wetlands         | 1% Annual Chance Flood Hazard |
| Proposed Pipeline  | On-site Perennial Stream     | On-site Emergent Wetland    | Regulatory Floodway           |
| Stream Impact      | Off-site Perennial Stream    | On-site Forested Wetland    |                               |
| Wetland Impact     | On-site Intermittent Stream  | On-site Shrub Scrub Wetland |                               |
| Stormwater Inlet   | Off-site Intermittent Stream | Off-Site Wetland            |                               |
| Culvert            | On-site Ephemeral Stream     |                             |                               |



**Figure 1**  
**Impacts Map 6 of 6**  
 PIR 2788 - Apple Creek  
 Dominion Energy Ohio  
 Wayne County, Ohio  
 Date: 1/17/2024



**Attachment B**

Aquatic Resources Delineation Report





> **Aquatic Resources Delineation Report**  
**PIR 2788 – Apple Creek**  
**Wooster Township, Wayne County, Ohio**

November 2023  
ECT No. 200336-0001

The East Ohio Gas Company, d/b/a Dominion Energy Ohio  
320 Springside Drive, Suite 320  
Akron, Ohio 44333



161 East Aurora Road  
Northfield, OH 44067  
[www.ectinc.com](http://www.ectinc.com)



## Table of Contents

<b>Executive Summary .....</b>	<b>1</b>
<b>1.0 Introduction and Methodology .....</b>	<b>2</b>
<b>2.0 Available Mapping and Data.....</b>	<b>5</b>
2.1 Aerial Imagery Review .....	5
2.2 U.S. Geological Survey Topographic Map.....	5
2.3 National Wetland Inventory and National Hydrography Dataset Map .....	5
2.4 USDA-NRCS Soils Map .....	6
2.5 FEMA Floodplain Map.....	6
2.6 401 Water Quality Certification for Nationwide Permits Eligibility Maps (OHIO).....	6
<b>3.0 Results.....</b>	<b>7</b>
3.1 Wetlands .....	7
3.2 Streams .....	8
3.3 Upland Conditions .....	11
<b>4.0 Conclusions .....</b>	<b>12</b>
<b>5.0 References.....</b>	<b>13</b>
<b>Common Wetland Definitions .....</b>	<b>14</b>

## Appendices

Appendix A	Background and Delineation Maps
Appendix B	USACE Regional Delineation Dataforms
Appendix C	Ohio Rapid Assessment Method (ORAM) Dataforms
Appendix D	Photographic Log
Appendix E	Qualitative Habitat Evaluation Index (QHEI) and Headwater Habitat Evaluation Index (HHEI) Forms

## List of Tables

Table 1. Ohio Rapid Assessment Method Scoring Breakpoints.....	3
Table 2. Wetland Summary Data.....	7
Table 3. Stream Summary Data .....	10

## List of Acronyms and Abbreviations

CWA	Clean Water Act
DEO	Dominion Energy Ohio
ECT	Environmental Consulting & Technology, Inc.
FAC	Facultative
FACU	Facultative Upland
FACW	Facultative Wetland
FEMA	Federal Emergency Management Agency
FIRM	Federal Insurance Rate Map
GNSS	Global Navigation Satellite System
GPS	Global Positioning System
HUC	Hydrologic Unit Code
NHD	National Hydrography Dataset
NRCS	Natural Resources Conservation Service
NWI	National Wetlands Inventory
NWP	USACE Nationwide Permit
OBL	Obligate Wetland
ODNR	Ohio Department of Natural Resources
OEPA	Ohio Environmental Protection Agency
OHWM	Ordinary High Water Mark
ORAM	Ohio Rapid Assessment Method
PHW	Primary Headwater
Project	PIR 2788 - Apple Creek
SCOTUS	Supreme Court of the United States
SFHA	Special Flood Hazard Area
UPL	Obligate Upland
USACE	U.S. Army Corps of Engineers
USEPA	U.S. Environmental Protection Agency
USDA	U.S. Department of Agriculture
USFWS	U.S. Fish and Wildlife Service
USGS	U.S. Geological Survey
WQC	Water Quality Certification
WOTUS	Waters of the United States



## Executive Summary

The East Ohio Gas Company, d/b/a Dominion Energy Ohio (DEO) contracted Environmental Consulting & Technology, Inc. (ECT), to perform a wetland and stream delineation for the PIR 2788 - Apple Creek (Project) site located in Wooster Township, Wayne County, Ohio. The Project is also located in the Walhonding River watershed (Hydrologic Unit Code [HUC] 05040003).

The Project Study Area comprises approximately 40 feet from the edge of pavement along N. Hillcrest Drive as well as an existing sixty (60)-ft wide utility easement which originates at N. Hillcrest Drive and extends northeast to S. Geyers Chapel Road, and a newly acquired sixty (60)-foot wide easement which originates as a private drive on the east side of N. Hillcrest Drive and extends east to Apple Creek (Project Study Area, *Site Location Map* in **Appendix A: Figure 1**). The Project Study Area is dominated by undeveloped, agricultural, and rural residential areas. The Project Study Area primarily has land cover of deciduous forest, agricultural fields, emergent and forested wetlands, a managed utility easement, maintained lawn, Apple Creek, road right-of-way (ROW), and developed land/paved areas. ECT conducted field surveys to identify, delineate, and characterize wetlands on May 13 and November 18, 2020, March 4 and April 30, 2021, and July 8, 2022.

Under Section 404 of the 1972 Clean Water Act (CWA), Waters of the United States (WOTUS) are regulated by the U.S. Army Corps of Engineers (USACE). In addition, the Ohio Environmental Protection Agency (OEPA) regulates non-federally jurisdictional wetlands and perennial and intermittent streams within the state of Ohio. Within regulated areas, a permit is required for activities such as, but not limited to, the placement of fill, dredging of material, draining of surface water, or constructing a structure within a regulated wetland or stream.

One (1) wetland (Wetland A) and six (6) streams (Streams 1 through 6) were identified within the Project Study Area.

## 1.0 Introduction and Methodology

The East Ohio Gas Company, d/b/a Dominion Energy Ohio (DEO) contracted Environmental Consulting & Technology, Inc. (ECT), to perform a wetland and stream delineation for the PIR 2788 – Apple Creek (Project) site located in Wooster Township, Wayne County, Ohio. The Project is also located in the Walhonding River watershed (Hydrologic Unit Code [HUC] 05040003).

Under the 1972 Clean Water Act (CWA), Waters of the United States (WOTUS) are regulated by the U.S. Army Corps of Engineers (USACE) and are considered jurisdictional. These can include such bodies of water as lakes, ponds, rivers, tributaries, and wetlands. In addition, the Ohio Environmental Protection Agency (OEPA) is the state regulatory agency that regulates all wetlands determined non-jurisdictional by the USACE.

This report summarizes the surface water features identified within approximately 40 feet from the edge of pavement along N. Hillcrest Drive as well as a 100-ft wide survey area along an existing utility easement which originates northeast of N. Hillcrest Drive and extends northeast to S. Geyers Chapel Road, and a newly acquired easement which originates as a private drive on the east side of N. Hillcrest Drive and extends east to Apple Creek (Project Study Area, *Site Location Map* in **Appendix A: Figure 1**).

Prior to any field work, ECT conducted a preliminary site assessment of existing information and imagery, including aerial photographs, United States Geological Service (USGS) topographic maps, National Wetland Inventory (NWI) maps, soil survey maps, and Federal Emergency Management Agency (FEMA) Flood Insurance Rate Maps (FIRMs). The results of this desktop review were used to focus field efforts on protected natural resources that are likely to occur within the Project.

On May 13 and November 18, 2020, March 4 and April 30, 2021, and July 8, 2022, ECT conducted field investigations to identify, delineate, and characterize wetlands; and assess aquatic resources and streams.

Wetlands within the Project Study Area were delineated following the *1987 U.S. Army Corps of Engineers Wetland Delineation Manual* (Environmental Laboratory 1987) and *Regional Supplement to the Army Corps of Engineers Wetland Delineation Manual: Northcentral and Northeast Region* (USACE 2012) guidelines. The presence of wetlands is determined based on three (3) parameters: the presence of

hydrophytic vegetation (hydrophytes), hydric soils, and wetland hydrology. Potentially jurisdictional wetland boundaries were mapped using a sub-meter Trimble GEO7X® series global positioning system (GPS) unit or R1® Global Navigation Satellite System (GNSS) receiver and flagged in the field. Wetland data points and corresponding upland points were also mapped with the GEO7X® GPS unit or R1® GNSS receiver. USACE regional determination forms were completed for each wetland and its corresponding upland point.

Vegetation was identified by flowers, leaves, bark, twigs, stems, reproductive structures, and/or persistent remains from the preceding growing season. The wetland indicator status for vegetation noted during the evaluation was obtained from the USACE 2020 *National Wetland Plant List* (USACE 2020). Soil was evaluated by digging test pits sufficient to document hydric indicators, up to 20 inches deep. Soil conditions were evaluated using criteria established by the U.S. Department of Agriculture (USDA) Natural Resource Conservation Service (NRCS) *Field Indicators of Hydric Soils in the United States* (USDA-NRCS 2018) and soil colors were evaluated using a Munsell® color chart (Munsell Color 2009). Hydrology was evaluated through direct observation of primary indicators (e.g., standing water and/or saturated soil) and indirectly through observation of secondary hydrology indications (e.g., geomorphic position).

An Ohio Rapid Assessment Method (ORAM), Version 5.0, form was completed for all identified wetlands to evaluate wetland quality. ORAM measures several metrics including wetland hydrology, size, and habitat alteration. Each metric is scored then totaled to give a final ORAM score corresponding to an ORAM category (1 through 3). Category 1 wetlands represent low quality wetlands while Category 3 wetlands represent high quality wetlands. ORAMs were categorized based on the scoring breakpoints in **Table 1**. Wetlands that are classified within the gray zone between two (2) categories are regulated as the higher of the two (2) categories unless additional functional biological assessments are completed that demonstrate lower wetland quality.

**Table 1. Ohio Rapid Assessment Method Scoring Breakpoints**

ORAM Score	ORAM Category
0 - 29.9	1
30 - 34.9	1 or 2 Gray Zone
35 - 44.9	Modified 2
45 - 59.9	2
60 - 64.9	2 or 3 Gray Zone
65 - 100	3

Source: (Mack 2000).



Delineated streams were identified based on the presence of morphological features such as a defined bed and banks, presence of ordinary high water mark (OHWM), and evidence of water flow. Streams were separated into three (3) flow regimes: perennial, intermittent, and ephemeral. Perennial streams are classified as having regular water flow that can be seen year-round. Intermittent streams flow during certain times of the year; however, during dry periods they may not have any flowing surface water. Ephemeral streams have brief water flow typically exhibited during periods of rainfall in the immediate vicinity. Streams were also mapped using a sub-meter GEO7X® GPS unit or R1® GNSS Receiver.

Stream quality assessments were conducted following the OEPA's Qualitative Habitat Evaluation Index (QHEI) and Headwater Habitat Evaluation Index (HHEI) dependent upon stream size and/or maximum pool depth. Stream 1 (Apple Creek) has a watershed  $\geq 1$  square mile and a maximum pool depth  $\geq 40$  centimeters and was therefore assessed following the QHEI. Streams 2, 3, 4, 5, and 6 have a watershed  $< 1$  square mile and a maximum pool depth of  $< 40$  centimeters and were therefore assessed using the HHEI. Both methodologies assess several stream metrics, such as substrate type, and assign scores for each metric. Totaled scores are used to determine the general quality of streams.

## 2.0 Available Mapping and Data

The following sections provide the results of the desktop review of available mapping and data.

### 2.1 Aerial Imagery Review

Aerial imagery of the Project Study Area was reviewed before the field reconnaissance to identify past and current land use and potential aquatic resources. The aerial imagery review indicated that the Project Study Area has been mainly under agricultural and residential use with forested riparian areas along Apple Creek and the southern portion of the existing pipeline easement, with very little change, since at least 1994.

### 2.2 U.S. Geological Survey Topographic Map

The U.S. Geological Survey (USGS) Wooster 7.5-minute quadrangle map (1998) depicts the elevation within the Project Study Area at range 900 to 977 feet above mean sea level (*USGS Topographic - Wooster Quadrangle Map*, **Appendix A: Figure 2**, [USGS 1998]). One (1) stream, Apple Creek is depicted on the USGS map through the Project Study Area.

### 2.3 National Wetland Inventory and National Hydrography Dataset Map

The U.S. Fish and Wildlife Service (USFWS) National Wetlands Inventory (NWI) mapping database and the USGS National Hydrography Dataset (NHD) were reviewed to determine the likely presence, location, size, and type of aquatic resources that may be in the Project Study Area (USFWS 2023; USGS 2023). USFWS generates NWI maps through high altitude imagery. These maps were used for preliminary analysis only, as these maps may not accurately depict the extent or existence of wetland systems in a specific area, nor do these maps always correctly identify the types of wetlands present. On-site field mapping is required to determine the actual presence of wetlands and their types in the Project Study Area. Similarly, the USGS has developed the NHD that depicts features such as rivers, streams, and lakes based on available topographic maps. However, some topographic maps may not reflect the current topography of an area. Verification of all streams within the Project Study Area is necessary through on-site visits.

One (1) riverine NWI feature, Apple Creek, is mapped within the Project Study Area. The NWI feature is also mapped as an NHD stream. The NWI also maps freshwater forested/shrub wetland along the

riparian area of Apple Creek within the Project Study Area (*NWI and NHD Features Map, Appendix A: Figure 3*).

## **2.4 USDA-NRCS Soils Map**

ECT reviewed the USDA-NRCS soil data for hydric soils that may be present within the Project Study Area. Hydric soils form under conditions of saturation, flooding, or ponding long enough during the growing season to develop anaerobic conditions in the upper part of the soil (USDA-NRCS 2018). Seven (7) soil map types are mapped within the Project Study Area, none of which are hydric soils or predominantly hydric soils. **Appendix A: Figure 4** presents a soils map showing the soil types and their boundaries within the Project Study Area as well as a list of all soil types.

## **2.5 FEMA Floodplain Map**

The Ohio Department of Natural Resources (ODNR) regulates development in FEMA identified floodways and floodplains, also called Special Flood Hazard Areas (SFHAs), under the Flood Control Act and Floodplain Management Rule. FEMA's Federal Insurance Rate Maps (FIRM's) delineate these SFHAs and the risk premium zones applicable to the community (FEMA 2002). A review of the FIRMs indicated that a 1% annual chance floodplain (100-year floodplain) and a regulatory floodway, both associated with Apple Creek, extend across the northern portion of the Project Study Area (*FEMA Floodplains Map, Appendix A: Figure 5*, [FEMA 2023]).

## **2.6 401 Water Quality Certification for Nationwide Permits Eligibility Maps (OHIO)**

The OEPA administers Section 401 of the Clean Water Act within the state of Ohio. As part of the 401 Water Quality Certification (WQC) conditions for the 2022 Nationwide Permits (NWP's), OEPA designated high-quality watersheds within the state of Ohio that are ineligible or possibly eligible for WQC under the NWP's. Review of the OEPA 401 WQC for NWP's Eligibility online map determined that this Project is located within a protected watershed and is ineligible for 401 WQC under the 2022 NWP's (*401 WQC Eligibility Map, Appendix A: Figure 6*, [OEPA 2023]). Impacts to streams within the Project would require an Individual 401 or Director's Authorization from OEPA if project impacts would be covered under a NWP authorized in 2022. However, this WQC condition does not apply to the set of NWP's authorized in 2021, including NWP 12 – Oil and Natural Gas Pipeline Activities.



### 3.0 Results

The following sections provide the results of the ECT field delineation.

#### 3.1 Wetlands

During the site reconnaissance, one (1) wetland (Wetland A) was identified within the Project Study Area and is shown on the *Aquatic Resources Delineation Map* (**Appendix A: Figure 7**). USACE Northcentral and Northeast Region wetland/upland data sheets are provided in **Appendix B**. A completed ORAM, version 5.0, form is provided in **Appendix C**. The identified wetland had soils that exhibited hydric indicators, observed hydrological characteristics, and a predominance of hydrophytic vegetation.

Sufficient reducing characteristics were observed within the upper 10 inches of soils, per guidelines set forth by the USDA-NRCS *Field Indicators of Hydric Soils in the United States* (USDA-NRCS 2018). Soils in Wetland A meet the conditions for the redox dark surface (F6) hydric soil indicator.

Hydrology indicators found within Wetland A included saturation (A3), sediment deposits (B2), drift deposits (B3), geomorphic position (D2), and FAC-neutral test (D5).

Typical vegetative conditions noted in Wetland A within the Project Study Area are described in the following paragraphs. The scientific names and wetland indicator status of vegetation (obligate wetland, OBL; facultative wetland, FACW; facultative, FAC; facultative upland, FACU; and obligate upland, UPL) noted during the delineation follow the common name the first time each plant species is referenced. **Appendix D** presents copies of site photographs depicting conditions at the time of the site investigation. **Table 2** provides details on the identified wetland within the Project Study Area.

**Table 2. Wetland Summary Data**

Wetland ID	ORAM Score	ORAM Category	PEM <sup>1</sup> in Study Area (acres)	PSS <sup>2</sup> in Study Area (acres)	PFO <sup>3</sup> in Study Area (acres)	Total Acres in Study Area
A	49	2	0.73	0.22	1.54	2.49

Source: (ECT 2023)

<sup>1</sup> Palustrine emergent

<sup>2</sup> Palustrine scrub-shrub

<sup>3</sup> Palustrine forested

Wetland A is a large (over one [1] acre) riparian wetland that abuts Stream 1 (Apple Creek) within the Project Study Area. Wetland A has forested, shrub, and emergent dominated portions. Woody vegetative cover in Wetland A is dominated by Ohio buckeye (*Aesculus glabra*, FAC), black cherry (*Prunus serotina*, FACU), American sycamore (*Platanus occidentalis*, FACW), cottonwood (*Populus deltoides*, FAC), and red maple (*Acer rubrum*, FAC). In forested and scrub-shrub portions of the wetland, the understory is dense with cover from Ohio buckeye and black cherry saplings, as well as multiflora rose (*Rosa multiflora*, FACU). Emergent portions of Wetland A are dominated by the invasive reed canary grass (*Phalaris arundinacea*, FACW). Emergent portions of Wetland A are also regularly mowed and cleared to maintain farm access. Wetland A received a score of 49 on the ORAM, placing it within Category 2. Wetland A drains directly into the perennial Stream 1 (Apple Creek).

### 3.2 Streams

The field reconnaissance completed by ECT identified six (6) streams (Stream 1 [Apple Creek] through Stream 6) within the Project Study Area as are shown on the *Aquatic Resources Delineation Map* (**Appendix A: Figure 7**). The identified streams exhibit morphological features such as a defined bed and banks, OHWM, and evidence of water flow. **Appendix D** presents copies of photographs depicting the aquatic features. **Table 2** provides the stream data. Most of the identified streams within the Project Study Area were associated with unnamed tributaries. One (1) named stream, Apple Creek, is located within the Project Study Area and associated with Stream 1. Completed OEPA QHEI and HHEI forms are provided in **Appendix E**.

Stream 1 (Apple Creek) is a large perennial stream that flows east to west across the Project Study Area. Dominant substrate types within Stream 1 (Apple Creek) include cobble and gravel. Although the assessed reach of Stream 1 (Apple Creek) is protected within a forested riparian area, the surrounding agricultural landscape likely influences sedimentation and nutrient loads within the stream. Stream 1 (Apple Creek) received a score of 69 on the QHEI, indicating it has potential to attain Warmwater Habitat. Apple Creek has been designated as Warmwater Habitat by the OEPA and the nearest sampling station #R03W47 was in partial attainment per the 2018 Integrated Water Quality Monitoring and Assessment Report (OEPA 2018).

Stream 2, an ephemeral stream, drains south through the Project Study Area along the western side of Geyers Chapel Road. At the time of the stream assessments, no water was observed within Stream 2, but a defined bed and bank were observed. Stream 2 is also culverted beneath a farm access road

immediately north of its confluence with Stream 1 (Apple Creek) within the eastern Project Study Area. Substrates of Stream 2 are dominated by silt and clay/hardpan. The stream has been channelized to run parallel to the road, and water quality is likely heavily influenced by stormwater from the adjacent roadway and agricultural fields. Stream 2 received a score of 13 on the HHEI, classifying it as a Modified Class I Primary Headwater (PHW).

Stream 3, an ephemeral stream, drains northwest through the Project Study Area. The stream has been channelized to run underneath the existing pipeline easement through a culvert and water quality is likely heavily influenced by stormwater from the surrounding residential area and agricultural fields. Stream 3 was flowing at the time of the March 2021 observation due to recent rainfall events. Substrates of Stream 3 are dominated by gravel, cobble, and sand. Stream 3 received a score of 46 on the HHEI classifying it as a Modified Class II PHW.

Stream 4 is an intermittent stream located in the western Project Study Area along a potential site access route. Stream 4 drains north through the Project Study Area and Wetland A into Stream 1 (Apple Creek) and was not flowing at the time of the site visit in April 2021. Stream 4 has been heavily channelized and is culverted beneath an existing field access road. Dominant substrate types within Stream 4 include gravel and clay/hardpan. Stream 4 is likely highly influenced by stormwater from the adjacent fallow fields/maintained lawn areas. Stream 4 received a score of 59 on the HHEI classifying it as a Modified Class II PHW.

Stream 5 is an ephemeral stream that originates in western portions of the Project Study Area and flows north towards Stream 1 (Apple Creek) where it eventually loses bed and bank within portions of Wetland A. The stream had no flow at the time of sampling in November 2020. Dominant substrate types of Stream 5 include cobble and clay/hardpan. Stream 5 received a score of 30 on the HHEI, placing it within the Class II PHW designation.

Stream 6 is an ephemeral stream captured in a roadside ditch along the western edge of North Hillcrest Drive. The stream had no flow at the time of sampling in November 2020. Dominant substrate types in Stream 6 include boulder and cobble. Stream 6 is heavily impacted by stormwater runoff from the adjacent roadway. Stream 6 received a score of 48 on the HHEI, placing it within the Modified Class II PHW designation.



**Table 3. Stream Summary Data**

Stream ID	Associated Waterway	Flow Regime	QHEI/HHEI Score	Class/Designation	Substrate Types	OWHM Width (ft)	Linear Feet
1	Apple Creek	Perennial	69	Warm Water Habitat	Cobble, gravel	48	180
2	Unnamed Tributary	Ephemeral	13	Modified Class I PHW <sup>1</sup>	Silt, clay/hardpan	2	155
3	Unnamed Tributary	Ephemeral	46	Modified Class II PHW	Gravel/sand	6	83
4	Unnamed Tributary	Intermittent	59	Modified Class II PHW	Gravel, clay/hardpan	9	93
5	Unnamed Tributary	Ephemeral	30	Class II PHW	cobble, clay/hardpan	4	83
6	Unnamed Tributary	Ephemeral	48	Modified Class II PHW	boulder, cobble	4	673
<b>Perennial Total</b>							<b>180</b>
<b>Intermittent Total</b>							<b>93</b>
<b>Ephemeral Total</b>							<b>994</b>
<b>TOTAL</b>							<b>1,267</b>

Source: (ECT 2023)

<sup>1</sup> Primary Headwater

### 3.3 Upland Conditions

Upland areas of the Project Study Area included upland forests, agricultural fields, old/fallow fields, and maintained lawns. A map showing the location of vegetation communities within the Project Study Area is included in **Appendix A: Figure 8**.

**Upland woods:** Upland forest areas are composed primarily of American sycamore, green ash (*Fraxinus pennsylvanica*, FACW), osage-orange (*Maclura pomifera*, FACU), red maple, and red oak (*Quercus rubra*, FACU).

**Agricultural fields:** The northeastern corner of the existing utility easement is dominated by agricultural fields planted with corn crop (*Zea mays*, UPL).

**Old/Fallow Fields:** Fallow fields within the Project Study Area are dominated by common Timothy (*Phleum pratense*, FACU), common dandelion (*Taraxacum officinale*, FACU), and red clover (*Trifolium pratense*, FACU).

**Maintained Lawns:** Maintained lawns are dominated by Kentucky blue grass (*Poa pratensis*, FACU).

Soil in uplands typically consist of 0 to 17 inches of dark yellowish brown sandy loams, and brown silty clay loams. Upland soils lacked the redoximorphic features found in hydric soils. There was no indication of wetland hydrology in upland areas.

## 4.0 Conclusions

ECT conducted a wetland and stream delineation on a 12.7-acre site for PIR 2788-Apple Creek located within Wooster Township, Wayne County, Ohio. One (1) wetland totaling 2.49 acres and six (6) streams totaling 1,267 linear feet were identified within the Project Study Area.

ECT's evaluation was performed in accordance with generally accepted procedures for conducting wetland and stream evaluations. ECT's conclusion reflects our professional opinion based on conditions present at the time of the evaluation. Discrepancies may arise between current and future evaluation of wetlands and streams of the Project Study Area due to changes in land use, vegetation, and/or hydrology.



## 5.0 References

- Environmental Laboratory. 1987. "Corps of Engineers Wetlands Delineation Manual. Wetlands Research Program - Technical Report Y-87-1." U.S. Army Corps of Engineers.
- FEMA. 2002. "National Flood Insurance Program - Program Description." Federal Emergency Management Agency, Federal Insurance & Mitigation Administration.
- . 2023. "National Flood Hazard Layer (NFHL) Viewer [ArcGIS Web Application]." 2023. <https://hazards-fema.maps.arcgis.com/apps/webappviewer/index.html?id=8b0adb51996444d4879338b5529aa9cd>.
- Mack, John J. 2000. "ORAM v 5.0 Quantitative Score Calibration." OEPA-Wetland Ecology Unit Division of Surface Water.
- Munsell Color. 2009. *Munsell Soil Color Charts: With Genuine Munsell Color Chips*. Grand Rapids, Michigan.
- OEPA. 2018. "2018 Ohio Integrated Water Quality and Assessment Report." 2018. <https://www.epa.ohio.gov/dsw/tmdl/OhioIntegratedReport>.
- . 2023. "Eligibility for Ohio EPA 401 Water Quality Certification Nationwide Permit [Geospatial Mapping Application]." Ohio Environmental Protection Agency (OEPA), Division of Surface Water. <https://www.arcgis.com/apps/webappviewer/index.html?id=e6b46d29a38f46229c1eb47deef e49b6>.
- USACE. 2012. "Regional Supplement to the Corps of Engineers Wetland Delineation Manual: Northcentral and Northeast Region. (Version 2.0)." ERDC/EL TR-12-1. U.S. Army Corps of Engineers. <https://usace.contentdm.oclc.org/utills/getfile/collection/p266001coll1/id/7640>.
- . 2020. "2020 National Wetland Plant List (Version 3.5)." U.S. Army Corps of Engineers. [https://wetland-plants.sec.usace.army.mil/nwpl\\_static/v34/home/home.html](https://wetland-plants.sec.usace.army.mil/nwpl_static/v34/home/home.html).
- USDA-NRCS. 2018. "Field Indicators of Hydric Soils in the United States: A Guide for Identifying and Delineating Hydric Soils, Version 8.2, 2018." Edited by LM Vasilas, GW Hurt, and JF Berkowitz. US Dep. of Agriculture (USDA) - Natural Resources Conservation Service (NRCS). [https://www.nrcs.usda.gov/sites/default/files/2022-09/Field\\_Indicators\\_of\\_Hydric\\_Soils.pdf](https://www.nrcs.usda.gov/sites/default/files/2022-09/Field_Indicators_of_Hydric_Soils.pdf).
- USFWS. 2023. "NWI." National Wetlands Inventory - Wetlands Mapper. 2023. <https://www.fws.gov/wetlands/data/Mapper.html>.
- USGS. 1998. "Wooster Quadrangle, Ohio." 7.5-Minute Series (Topographic). U.S. Geological Survey.
- . 2023. "National Hydrography Dataset (NHD)." 2023. <https://www.usgs.gov/national-hydrography/national-hydrography-dataset>.

## Common Wetland Definitions

Perennial Stream: year-round streams, typically have water year-round. Water comes from upstream tributaries or headwaters as well as precipitation.

Intermittent Streams: have water intermittently throughout the year when upstream waters or groundwater provide enough stream flow. May not have flowing surface water during dry times of the year.

Palustrine Emergent Wetland (PEM): Vegetative classification of a wetland system based on the dominant vegetation, consisting of rooted herbaceous (non-woody) plant species that have parts extending above a water surface with at least 30% aerial coverage.

100-year flood: A flood with a magnitude that has a 1% chance of occurring or being exceeded in any given year.

Floodplain: The area of land adjoining a river or stream that will be inundated by a 100-year flood.

Hydric soil: Soil that is saturated, flooded, or ponded long enough during the growing season to develop anaerobic conditions in the upper part (USDA-NRCS 2018).

Hydrophytes: Plant species that grows in water or on a substrate that is at least periodically deficient in oxygen because of excessive water content; plants typically found in wet habitats.

Isolated Wetland: "wetland that is not subject to regulation under the Federal Water Pollution Control Act" as described by OH Revised Code 6111.02.

Palustrine Scrub-Shrub Wetland (PSS): Vegetative classification of a wetland system based on the dominant vegetation consisting of woody plants less than 3 inches in diameter but greater than 3 ft but less than 20 ft in height OR where trees and shrubs combined have an aerial coverage no greater than 30%.

Palustrine Forested Wetland (PFO): Vegetative classification of a wetland system based on the dominant vegetation consisting of woody plants 3 inches in diameter or greater regardless of height with at least 30% aerial coverage.

*Traditional Navigable Water:* water body that is presently used or has been previously used in the past for transport by interstate or foreign commerce vessels.

*Wetland:* Defined by USACE as "...areas that are inundated or saturated by surface or ground water...at a frequency and duration sufficient to support, and that under normal circumstances do support, a prevalence of vegetation typically adapted for life in soil conditions."

*Wetland hydrology:* Hydrologic characteristics of areas that are periodically inundated or have soils saturated to the surface at some time during the growing season.

***Wetland Indicator Status:***

*OBL:* Obligate wetland plant that occurs almost always, 99% of the time, in wetlands under natural conditions, but which rarely occur in non-wetlands.

*FACW:* Facultative wetland plant that occurs usually, 67% to 99% of the time, in wetlands, but also occurs 1% to 33% of the time in non-wetlands.

*FAC:* Facultative plant that occurs in both wetlands and non-wetlands 33% to 67% of the time.

*FACU:* Plant that occurs sometimes, 1% to 33% of the time, in wetlands but occurs more often, 67% to 99% of the time, in non-wetlands.

*UPL:* Upland plant that occurs very rarely in wetlands, less than 1% of the time



## **Appendix A Background and Delineation Maps**

**Figure 1. Site Location Map**

**Figure 2 USGS Topographic -Wooster Quadrangle Map**

**Figure 3 NWI and NHD Features Map**

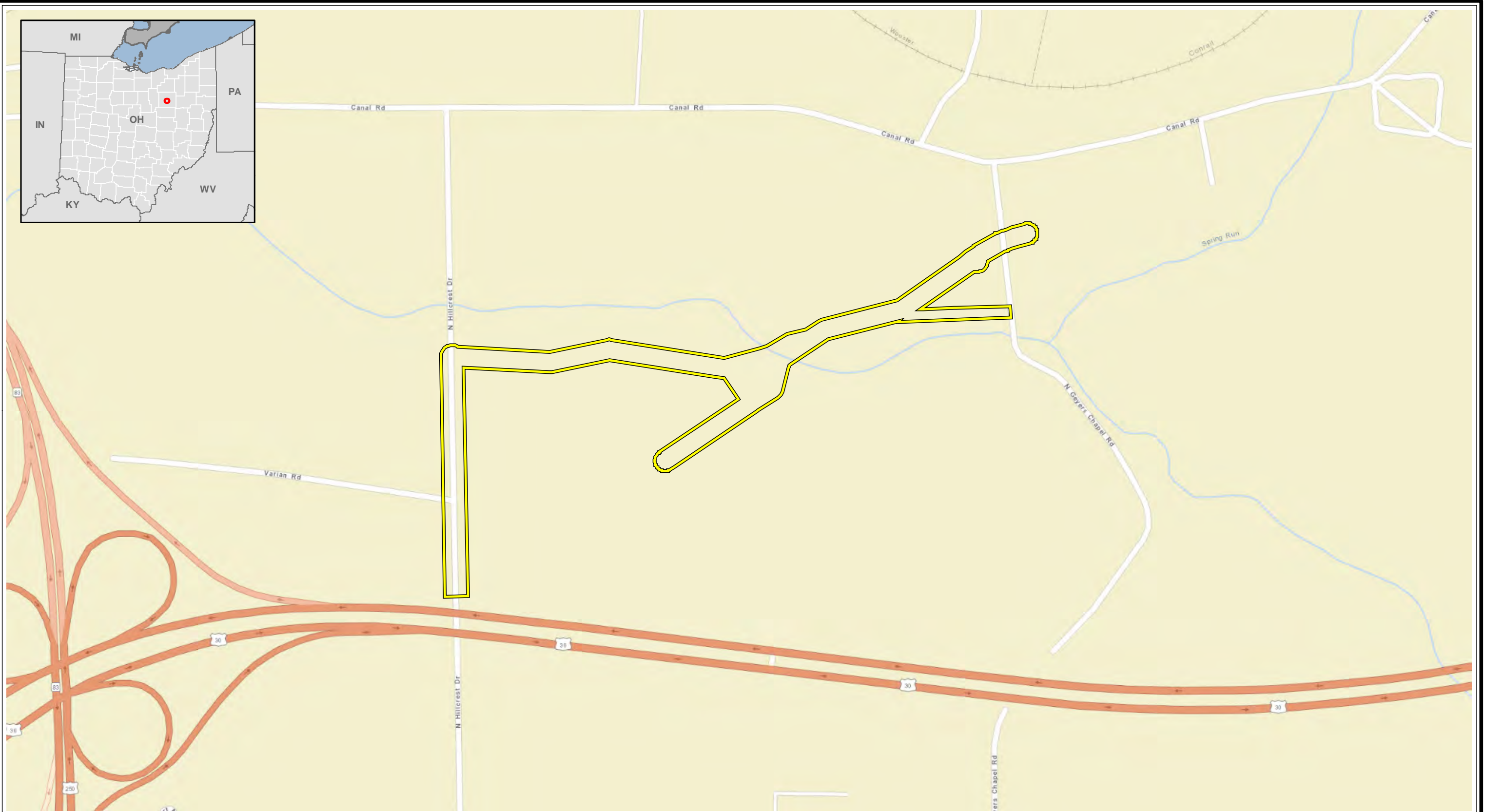
**Figure 4 NRCS Soil Survey Units Map**

**Figure 5 FEMA Floodplains Map**

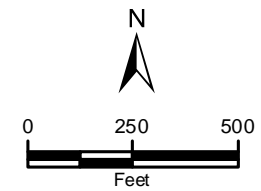
**Figure 6 401 WQC Eligibility Map**

**Figure 7 Aquatic Resources Delineation Map**

**Figure 8 Vegetation Communities Map**



 Project Study Area




Base Layer: ESRI Street Map 2019

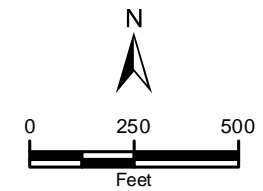
**Figure 1**  
**Site Location**  
PIR 2788 - Apple Creek  
Dominion Energy Ohio  
Wayne County, Ohio  
Date: 1/17/2024







 Project Study Area



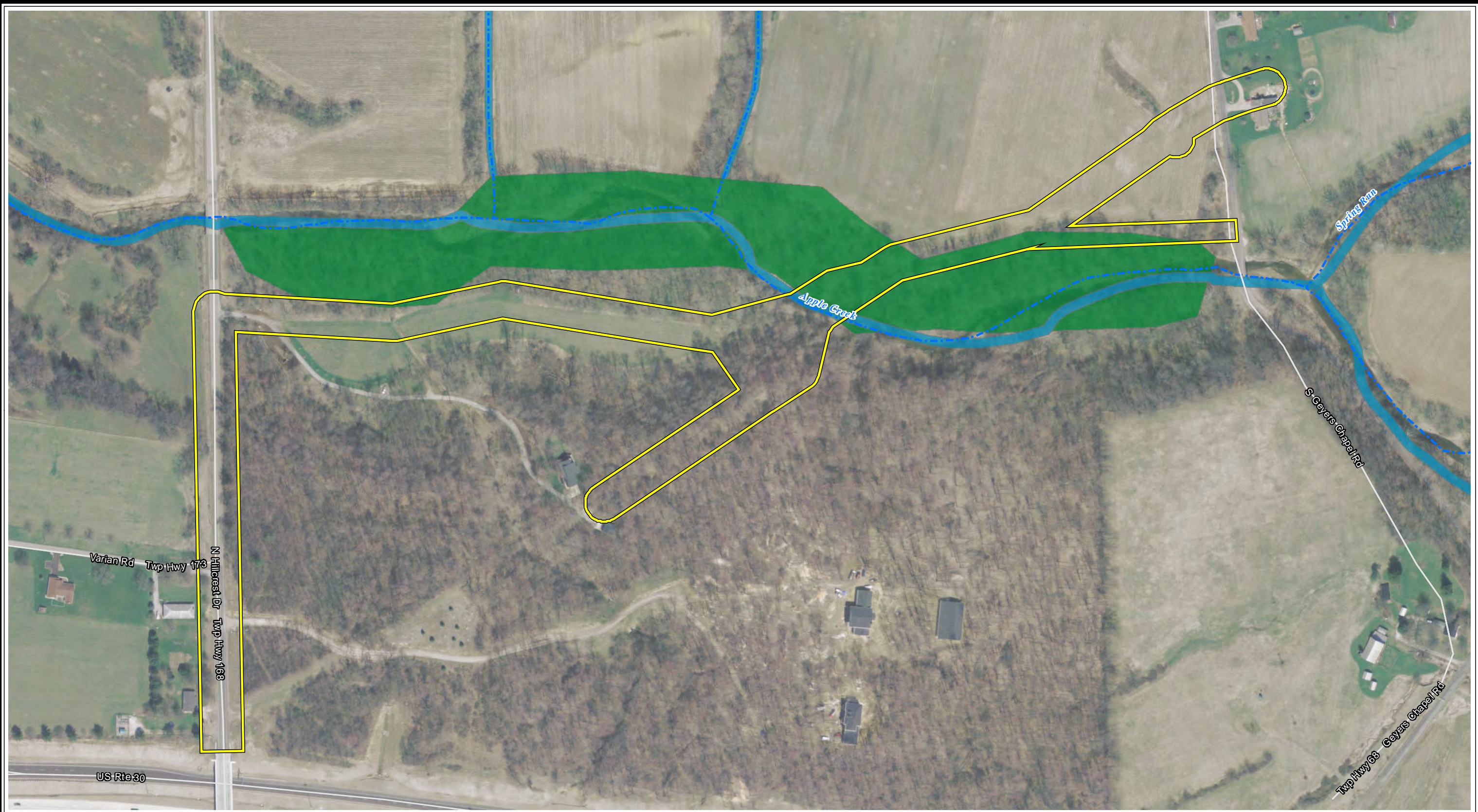
Base Layer: US TopoMaps, 1998

**Figure 2**  
**USGS Topographic - Wooster Quadrangle**

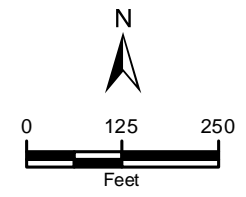
PIR 2788 - Apple Creek  
Dominion Energy Ohio  
Wayne County, Ohio  
Date: 1/17/2024







- Project Study Area NWI Wetlands
- NHD Flowline
- Freshwater Forested/Shrub Wetland
- NHD Waterbody
- Riverine



Base Layer: OSIP Aerial, 2016

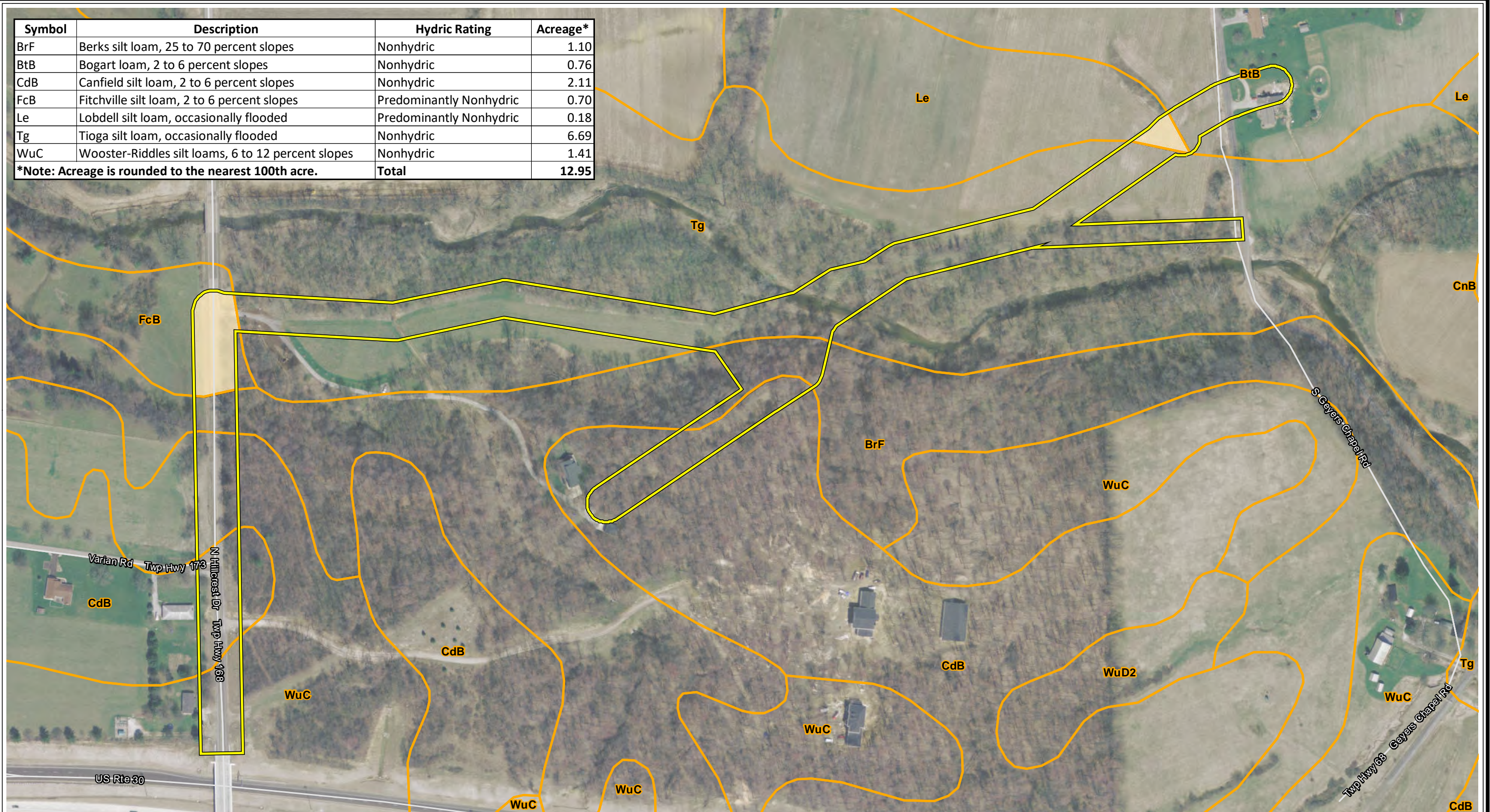
**Figure 3**  
**NWI and NHD Features**

PIR 2788 - Apple Creek  
 Dominion Energy Ohio  
 Wayne County, Ohio  
 Date: 1/17/2024

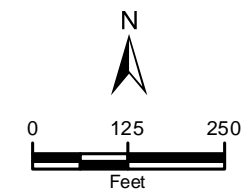




Symbol	Description	Hydric Rating	Acreage*
BrF	Berks silt loam, 25 to 70 percent slopes	Nonhydric	1.10
BtB	Bogart loam, 2 to 6 percent slopes	Nonhydric	0.76
CdB	Canfield silt loam, 2 to 6 percent slopes	Nonhydric	2.11
FcB	Fitchville silt loam, 2 to 6 percent slopes	Predominantly Nonhydric	0.70
Le	Lobdell silt loam, occasionally flooded	Predominantly Nonhydric	0.18
Tg	Tioga silt loam, occasionally flooded	Nonhydric	6.69
WuC	Wooster-Riddles silt loams, 6 to 12 percent slopes	Nonhydric	1.41
<b>*Note: Acreage is rounded to the nearest 100th acre.</b>		<b>Total</b>	<b>12.95</b>



- Project Study Area
- NRCS Soils
- NRCS Soils - Hydric Rating
- Predominantly Nonhydric
- Nonhydric



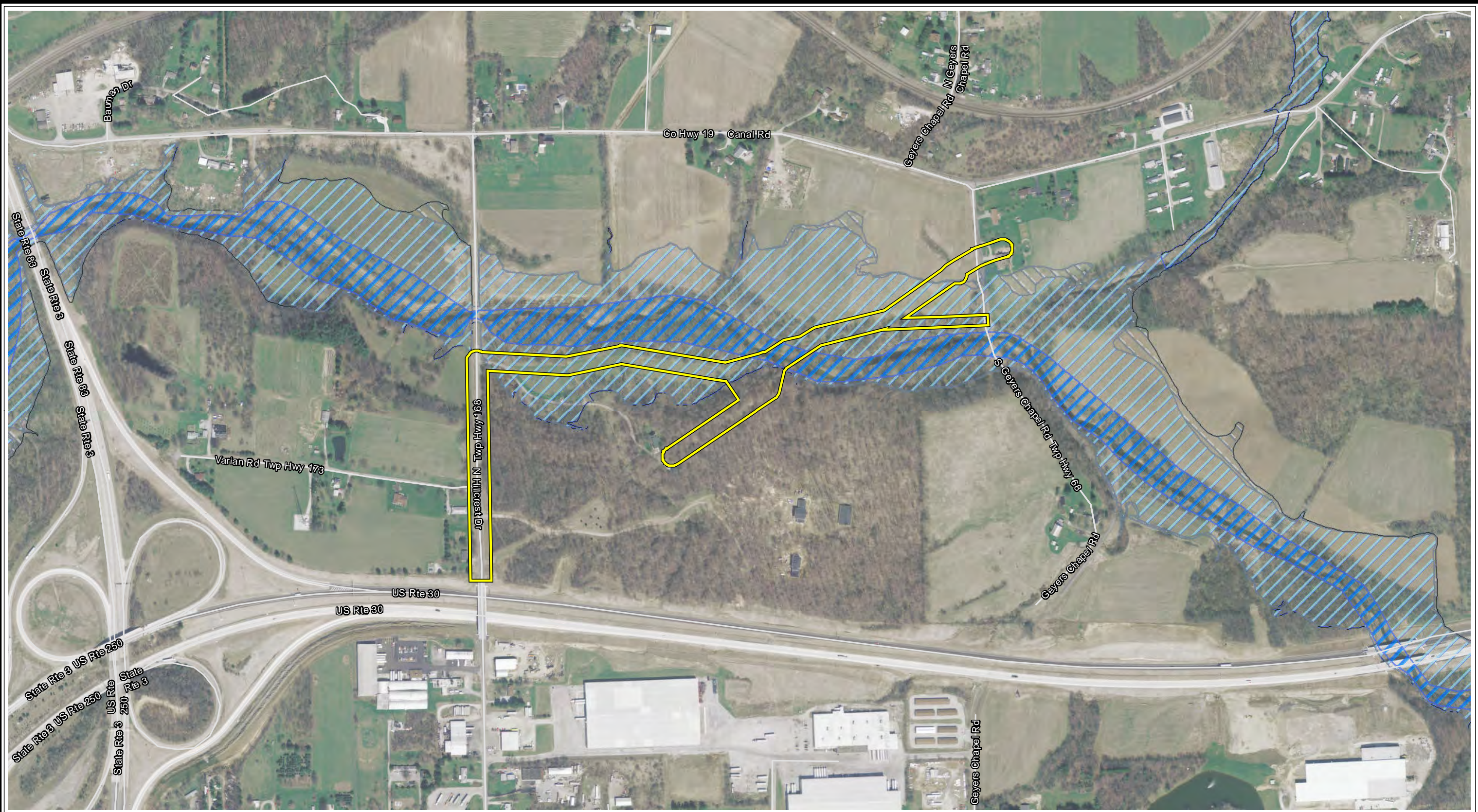
Base Layer: OSIP Aerial, 2016

**Figure 4**  
**NRCS Soil Survey Units**

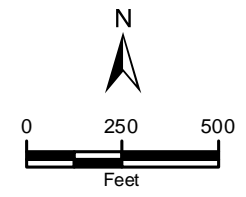
PIR 2788 - Apple Creek  
Dominion Energy Ohio  
Wayne County, Ohio  
Date: 1/17/2024







- Project Study Area
- Flood Zones (FEMA)
- 1% Annual Chance Flood Hazard
- Regulatory Floodway
- Zone X (Shaded) - 500-year Floodplain
- Zone X - Area of Minimal Flood Hazard

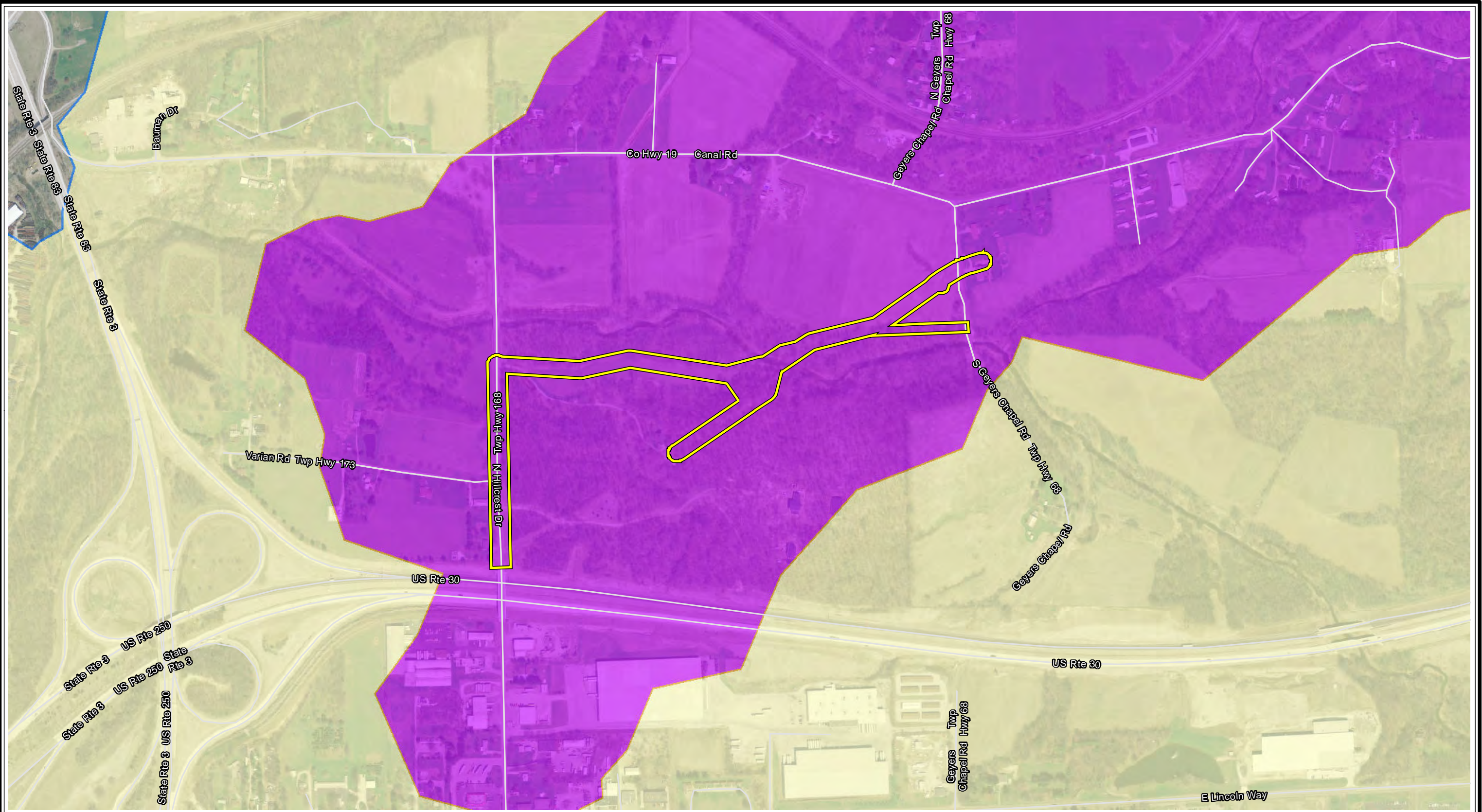


Base Layer: OSIP Aerial, 2016

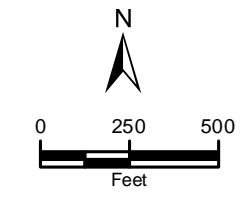
**Figure 5**  
**FEMA Floodplains**  
 PIR 2788 - Apple Creek  
 Dominion Energy Ohio  
 Wayne County, Ohio  
 Date: 1/17/2024







- Project Study Area
- 401 WQC Eligibility
- Eligible
- Ineligible
- Possibly Eligible

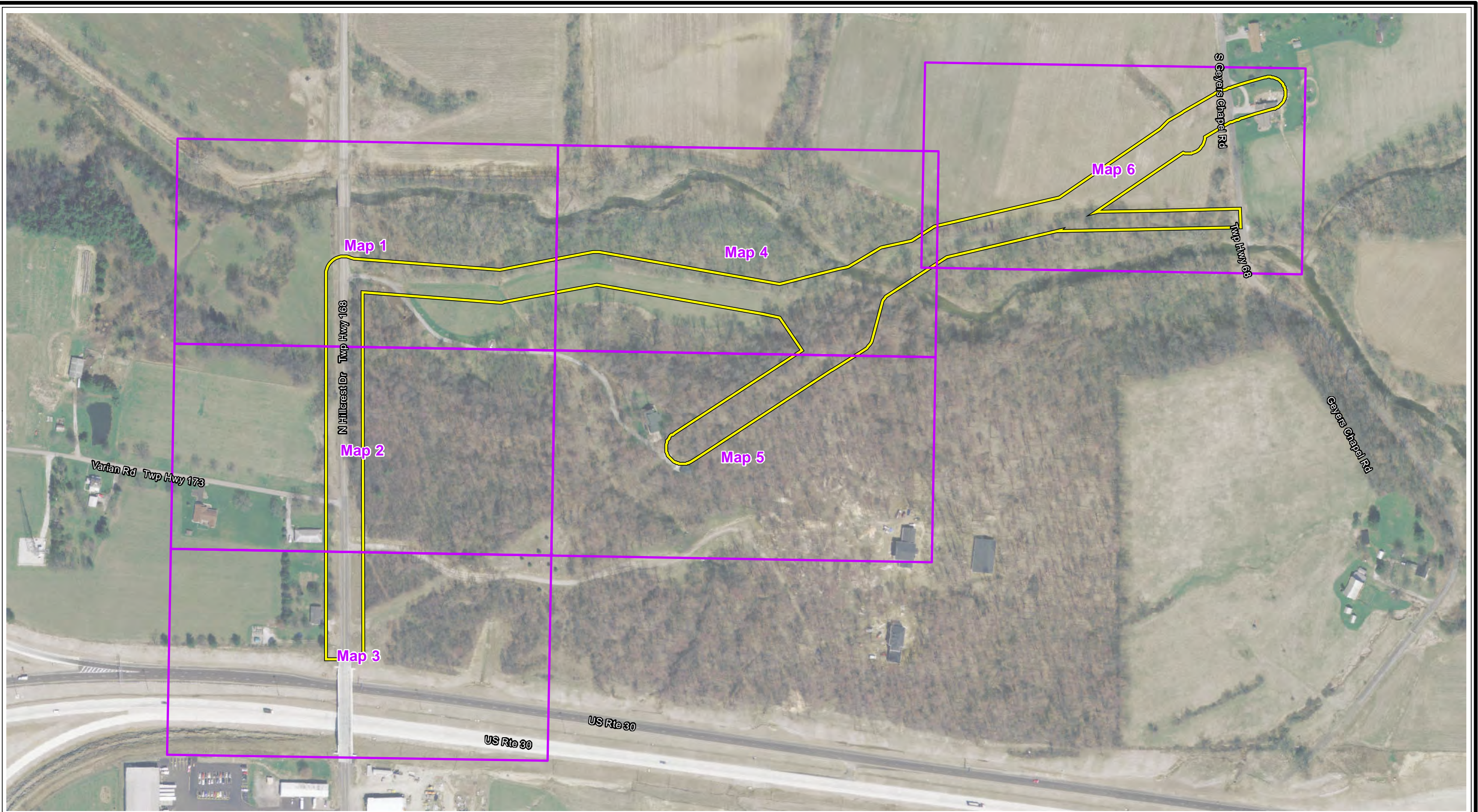


Base Layer: OSIP Aerial, 2016

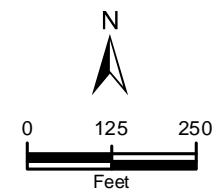
**Figure 6**  
**401 WQC Eligibility**  
 PIR 2788 - Apple Creek  
 Dominion Energy Ohio  
 Wayne County, Ohio  
 Date: 1/17/2024







Project Study Area  
 Map Extent



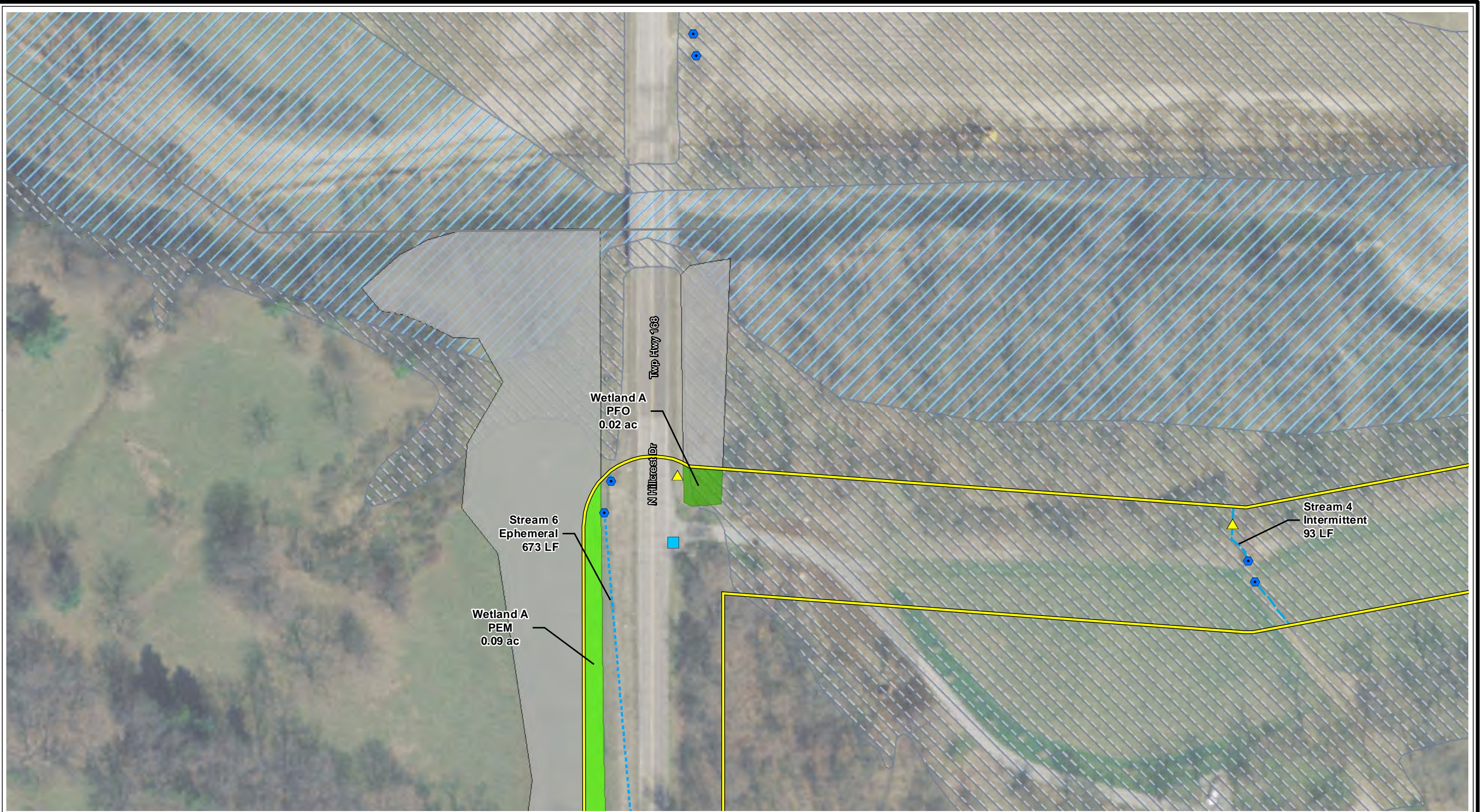
Base Layer: OSIP 2016

**Figure 7**  
**Aquatic Resources Delineation Map Book**

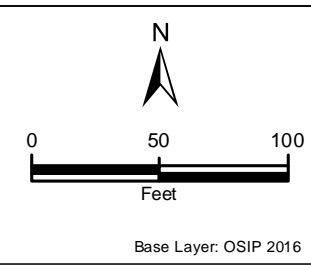
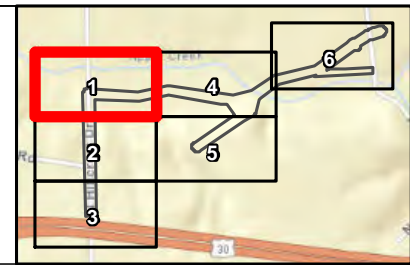
PIR 2788 - Apple Creek  
 Dominion Energy Ohio  
 Wayne County, Ohio  
 Date: 1/17/2024








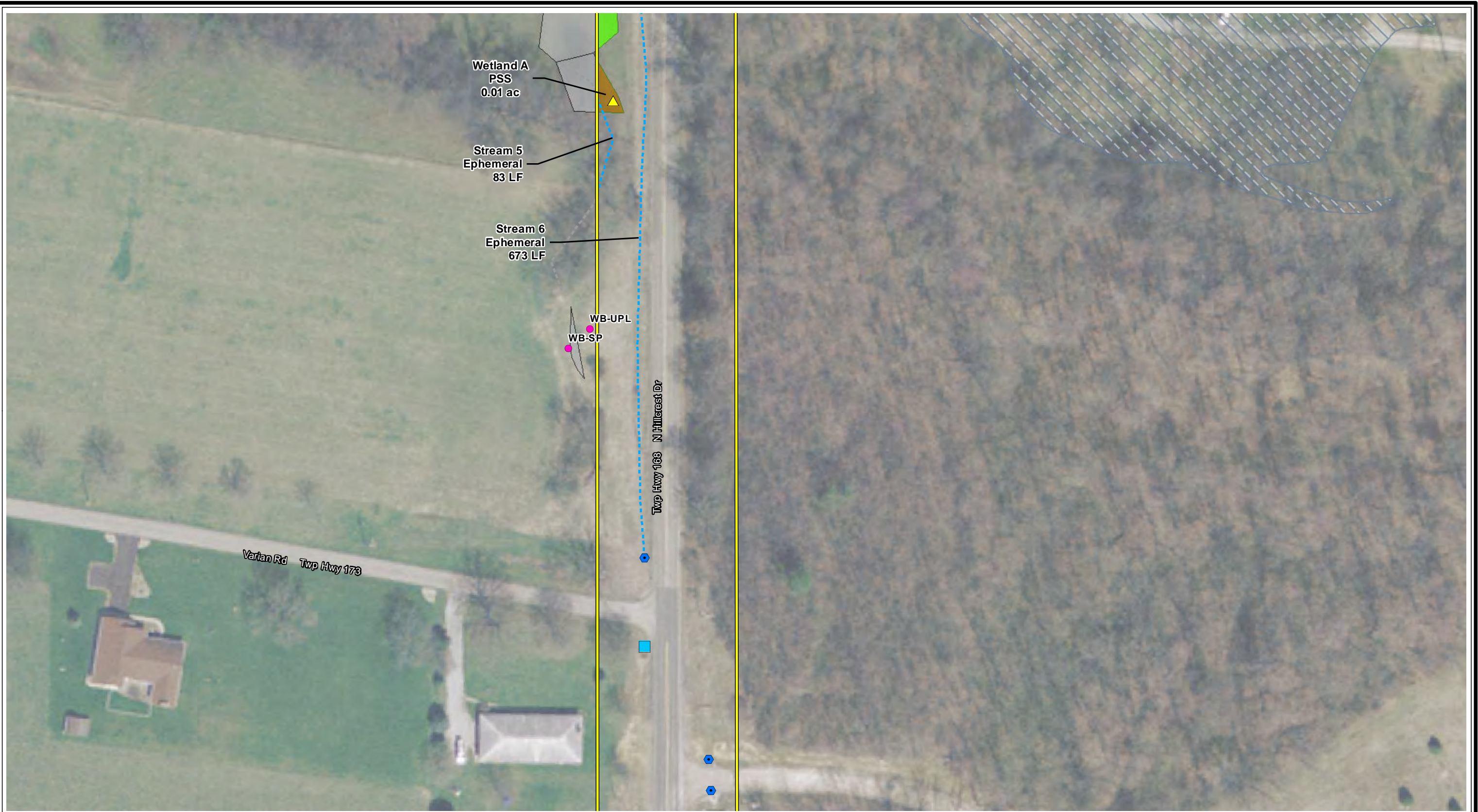
Project Study Area	Delineated Stream	Delineated Wetlands
Stormwater Inlet	On-site Perennial Stream	On-site Emergent Wetland
Culvert	Off-site Perennial Stream	On-site Forested Wetland
Temp Pipeline Marker	On-site Intermittent Stream	On-site Shrub Scrub Wetland
Perm Pipeline Marker	Off-site Intermittent Stream	Off-Site Wetland
Photo Location	On-site Ephemeral Stream	Flood Zones (FEMA)
Sample Point	Off-site Ephemeral Stream	1% Annual Chance Flood Hazard
		Regulatory Floodway



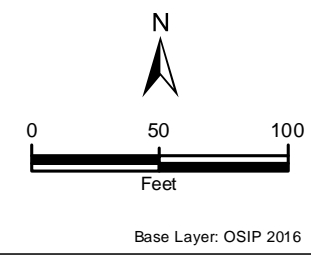
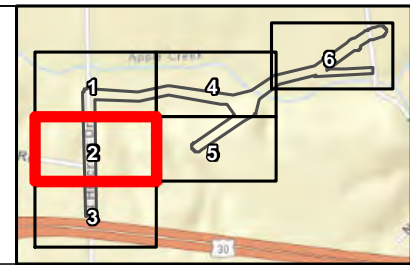
**Figure 7**  
**Aquatic Resources Delineation Map 1 of 6**  
 PIR 2788 - Apple Creek  
 Dominion Energy Ohio  
 Wayne County, Ohio  
 Date: 1/17/2024







Project Study Area	Delineated Stream	Delineated Wetlands
Stormwater Inlet	On-site Perennial Stream	On-site Emergent Wetland
Culvert	Off-site Perennial Stream	On-site Forested Wetland
Temp Pipeline Marker	On-site Intermittent Stream	On-site Shrub Scrub Wetland
Perm Pipeline Marker	Off-site Intermittent Stream	Off-Site Wetland
Photo Location	On-site Ephemeral Stream	Flood Zones (FEMA)
Sample Point	Off-site Ephemeral Stream	1% Annual Chance Flood Hazard
		Regulatory Floodway



**Figure 7**  
**Aquatic Resources Delineation Map 2 of 6**

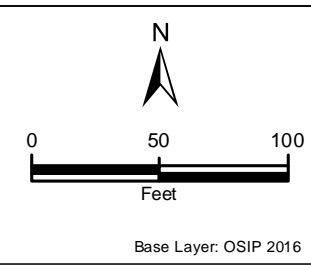
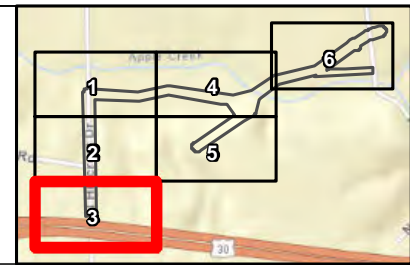
PIR 2788 - Apple Creek  
 Dominion Energy Ohio  
 Wayne County, Ohio  
 Date: 1/17/2024








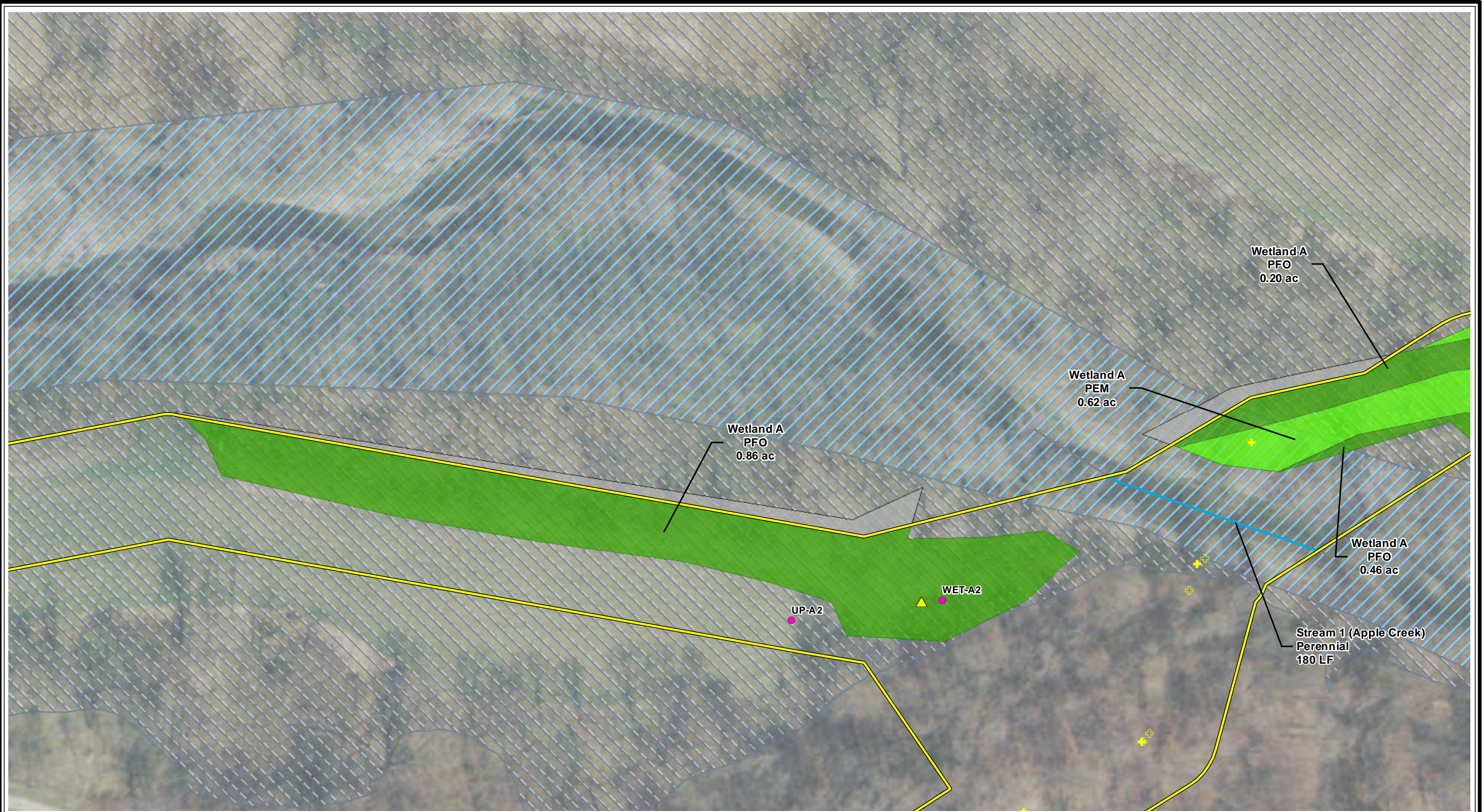
- |                      |                              |                               |
|----------------------|------------------------------|-------------------------------|
| Project Study Area   | <b>Delineated Stream</b>     | <b>Delineated Wetlands</b>    |
| Stormwater Inlet     | On-site Perennial Stream     | On-site Emergent Wetland      |
| Culvert              | On-site Intermittent Stream  | On-site Forested Wetland      |
| Temp Pipeline Marker | On-site Ephemeral Stream     | On-site Shrub Scrub Wetland   |
| Perm Pipeline Marker | Off-site Perennial Stream    | Off-Site Wetland              |
| Photo Location       | Off-site Intermittent Stream | <b>Flood Zones (FEMA)</b>     |
| Sample Point         | Off-site Ephemeral Stream    | 1% Annual Chance Flood Hazard |
|                      |                              | Regulatory Floodway           |



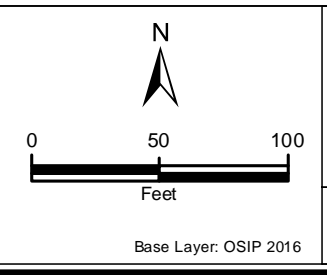
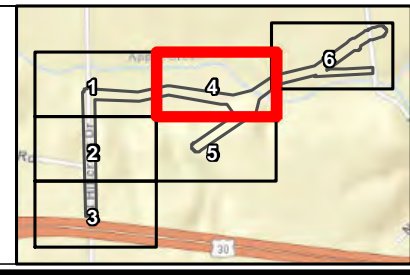
**Figure 7**  
**Aquatic Resources Delineation Map 3 of 6**  
 PIR 2788 - Apple Creek  
 Dominion Energy Ohio  
 Wayne County, Ohio  
 Date: 1/17/2024








Project Study Area	Delineated Stream	Delineated Wetlands
Stormwater Inlet	On-site Perennial Stream	On-site Emergent Wetland
Culvert	Off-site Perennial Stream	On-site Forested Wetland
Temp Pipeline Marker	On-site Intermittent Stream	On-site Shrub Scrub Wetland
Perm Pipeline Marker	Off-site Intermittent Stream	Off-Site Wetland
Photo Location	On-site Ephemeral Stream	Flood Zones (FEMA)
Sample Point	Off-site Ephemeral Stream	1% Annual Chance Flood Hazard
		Regulatory Floodway



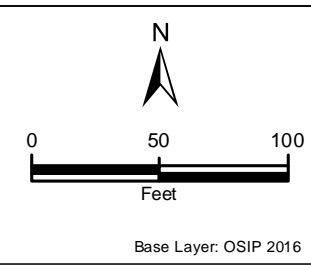
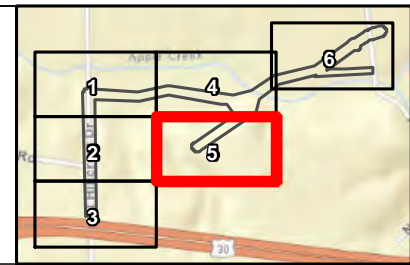
**Figure 7**  
**Aquatic Resources Delineation Map 4 of 6**  
 PIR 2788 - Apple Creek  
 Dominion Energy Ohio  
 Wayne County, Ohio  
 Date: 1/17/2024





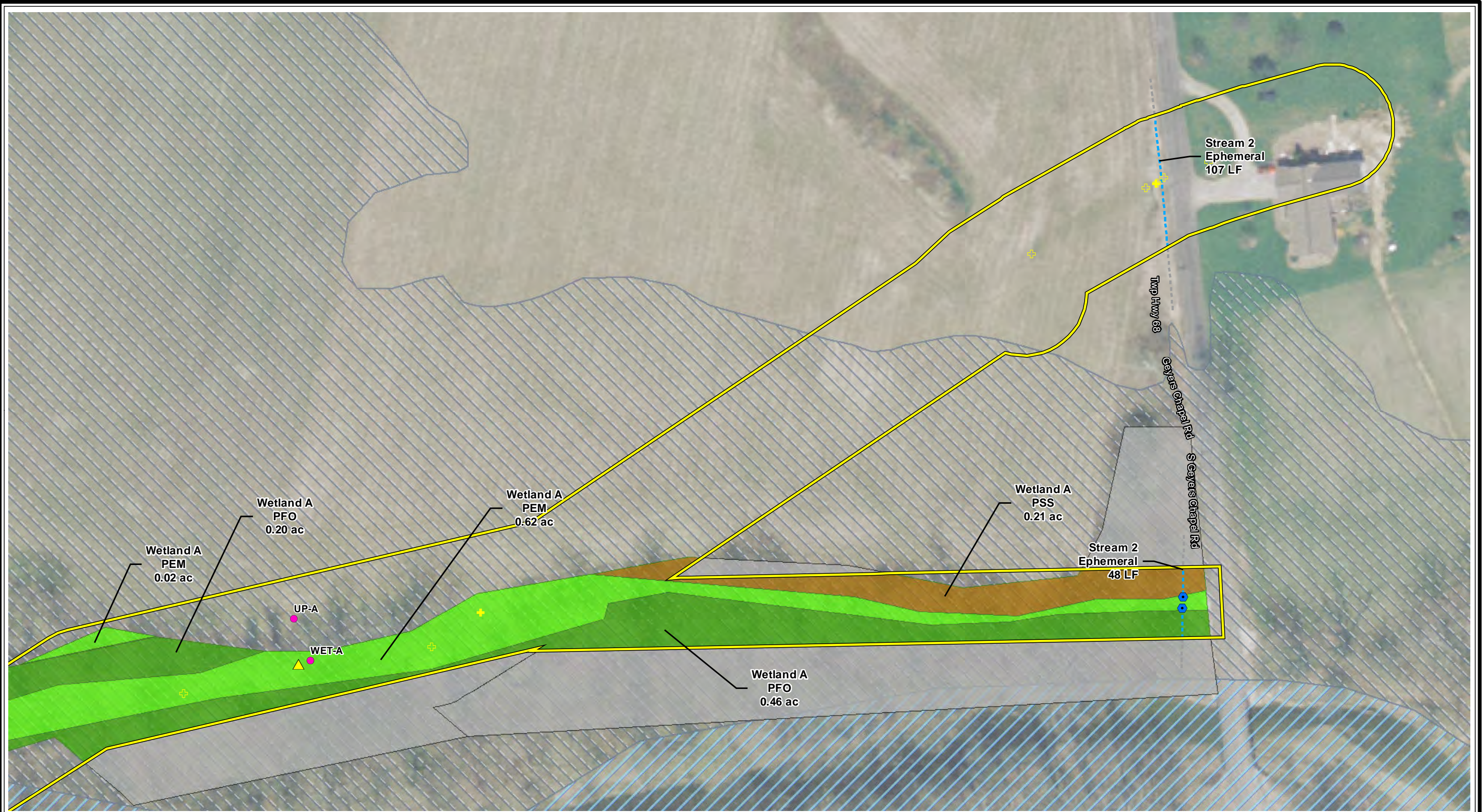


Project Study Area	<b>Delineated Stream</b>	<b>Delineated Wetlands</b>
Stormwater Inlet	On-site Perennial Stream	On-site Emergent Wetland
Culvert	On-site Intermittent Stream	On-site Forested Wetland
Temp Pipeline Marker	On-site Ephemeral Stream	On-site Shrub Scrub Wetland
Perm Pipeline Marker	Off-site Intermittent Stream	Off-Site Wetland
Photo Location	Off-site Ephemeral Stream	<b>Flood Zones (FEMA)</b>
Sample Point		1% Annual Chance Flood Hazard
		Regulatory Floodway

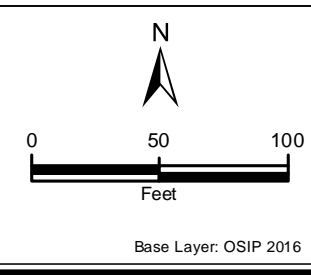
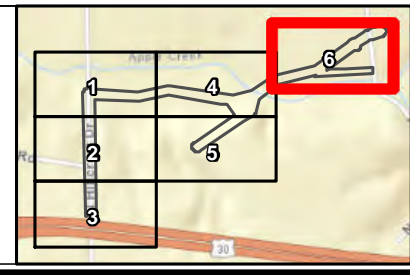


**Figure 7**  
**Aquatic Resources Delineation Map 5 of 6**  
 PIR 2788 - Apple Creek  
 Dominion Energy Ohio  
 Wayne County, Ohio  
 Date: 1/17/2024






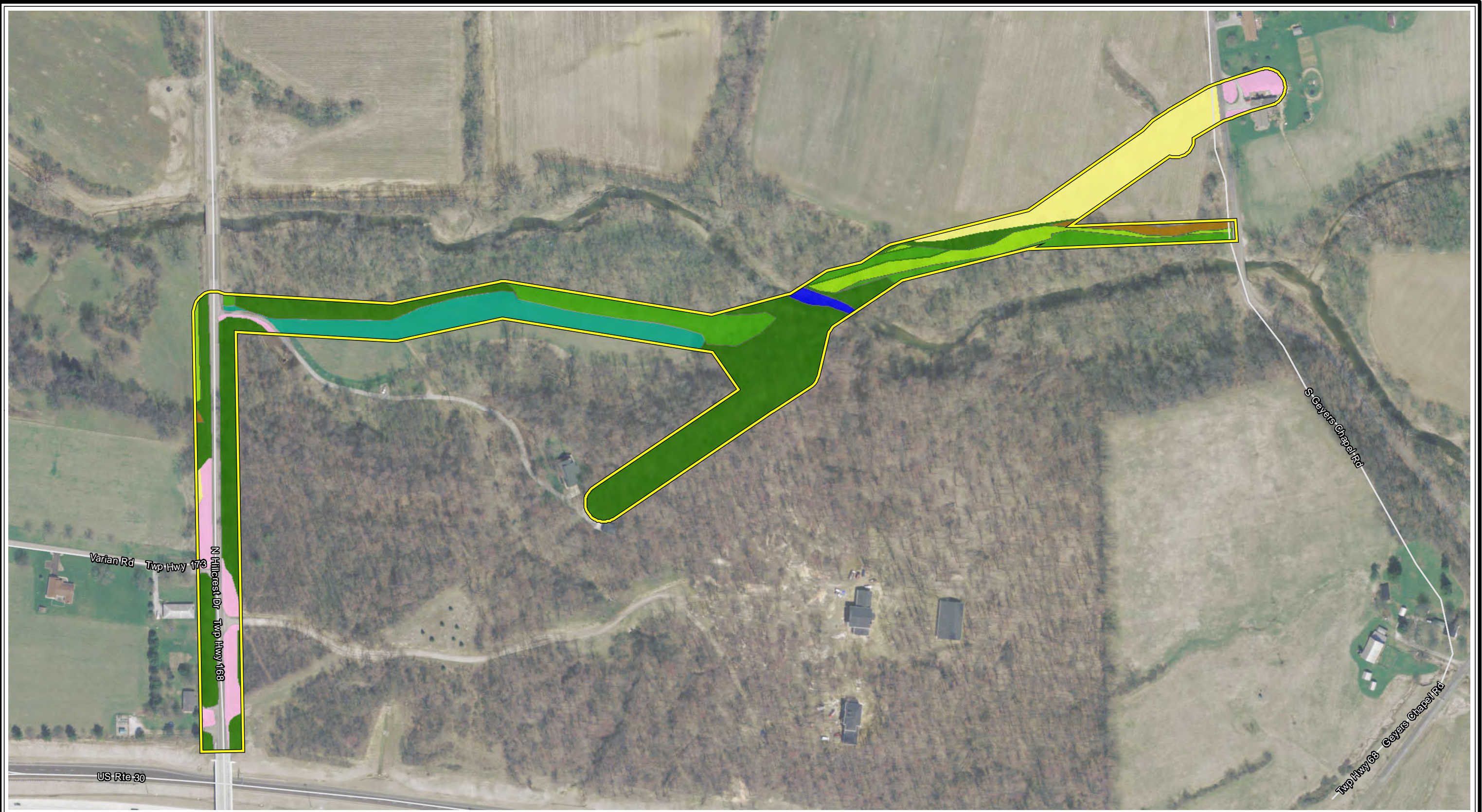
- |                      |                              |                               |
|----------------------|------------------------------|-------------------------------|
| Project Study Area   | Delineated Stream            | Delineated Wetlands           |
| Stormwater Inlet     | On-site Perennial Stream     | On-site Emergent Wetland      |
| Culvert              | Off-site Perennial Stream    | On-site Forested Wetland      |
| Temp Pipeline Marker | On-site Intermittent Stream  | On-site Shrub Scrub Wetland   |
| Perm Pipeline Marker | Off-site Intermittent Stream | Off-Site Wetland              |
| Photo Location       | On-site Ephemeral Stream     | Flood Zones (FEMA)            |
| Sample Point         | Off-site Ephemeral Stream    | 1% Annual Chance Flood Hazard |
|                      |                              | Regulatory Floodway           |



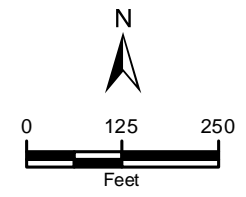
**Figure 7**  
**Aquatic Resources Delineation Map 6 of 6**  
 PIR 2788 - Apple Creek  
 Dominion Energy Ohio  
 Wayne County, Ohio  
 Date: 1/17/2024







- Project Study Area
- Open Water
- Old/Fallow Field
- Upland Forest
- Maintained Lawn
- Cultivated Cropland



Base Layer: OSIP Aerial, 2016

**Figure 8**  
**Vegetation Communities**

PIR 2788 - Apple Creek  
Dominion Energy Ohio  
Wayne County, Ohio  
Date: 1/17/2024





## Appendix B USACE Regional Delineation Dataforms

**WETLAND DETERMINATION DATA FORM - Northcentral and Northeast Region**

Project/Site: PIR 2788 City/County: Wayne County Sampling Date: May 13, 2020  
 Applicant/Owner: DEO State: Ohio Sampling Point: WET-A  
 Investigator(s): K. SIMON Section, Township, Range: S2 T15 R13W  
 Landform (hillslope, terrace, etc.): \_\_\_\_\_ Local Relief (concave, convex, none): \_\_\_\_\_ Slope (%): \_\_\_\_\_  
 Subregion (LRR or MLRA): LRR R Lat: 40.80328 Long: -81.89882 Datum: NAD83  
 Soil Map Unit Name: Tg - Tioga silt loam, occasionally flooded NWI classification: None  
 Are climatic/hydrologic conditions on the site typical for this time of year? Yes X No \_\_\_\_\_ (If no, explain in Remarks.)  
 Are Vegetation No, Soil No, or Hydrology No significantly disturbed? Are "Normal Circumstances" present?  
 Yes X No \_\_\_\_\_  
 Are Vegetation No, Soil No, or Hydrology No naturally problematic? (If needed, explain any answers in Remarks.)

**SUMMARY OF FINDINGS - Attach site map showing sampling point locations, transects, important features, etc.**

Hydrophytic Vegetation Present?	Yes <u>X</u>	No _____	Is the Sampled Area within a Wetland? Yes <u>X</u> No _____
Hydric Soil Present?	Yes <u>X</u>	No _____	If yes, optional Wetland Site ID: <u>WET-A</u>
Wetland Hydrology Present?	Yes <u>X</u>	No _____	
Remarks:			

**HYDROLOGY**

Wetland Hydrology Indicators:	Secondary Indicators (minimum of two required)
Primary Indicators (minimum of one is required; check all that apply)	
<input type="checkbox"/> Surface Water (A1)	<input type="checkbox"/> Surface Soil Cracks (B6)
<input type="checkbox"/> High Water Table (A2)	<input type="checkbox"/> Drainage Patterns (B10)
<input checked="" type="checkbox"/> Saturation (A3)	<input type="checkbox"/> Moss Trim Lines (B16)
<input type="checkbox"/> Water Marks (B1)	<input type="checkbox"/> Dry-Season Water Table (C2)
<input checked="" type="checkbox"/> Sediment Deposits (B2)	<input type="checkbox"/> Crayfish Burrows (C8)
<input checked="" type="checkbox"/> Drift Deposits (B3)	<input type="checkbox"/> Saturation Visible on Aerial Imagery (C9)
<input type="checkbox"/> Algal Mat or Crust (B4)	<input type="checkbox"/> Stunted or Stressed Plants (D1)
<input type="checkbox"/> Iron Deposits (B5)	<input checked="" type="checkbox"/> Geomorphic Position (D2)
<input type="checkbox"/> Inundation Visible on Aerial Imagery (B7)	<input type="checkbox"/> Shallow Aquitard (D3)
<input type="checkbox"/> Sparsely Vegetated Concave Surface (B8)	<input type="checkbox"/> Microtopographic Relief (D4)
<input type="checkbox"/> Water-Stained Leaves (B9)	<input type="checkbox"/> FAC-Neutral Test (D5)
<input type="checkbox"/> Aquatic Fauna (B13)	
<input type="checkbox"/> Marl Deposits (B15)	
<input type="checkbox"/> Hydrogen Sulfide Odor (C1)	
<input type="checkbox"/> Oxidized Rhizospheres on Living Roots (C3)	
<input type="checkbox"/> Presence of Reduced Iron (C4)	
<input type="checkbox"/> Recent Iron Reduction in Tilled Soils (C6)	
<input type="checkbox"/> Thin Muck Surface (C7)	
<input type="checkbox"/> Other (Explain in Remarks)	

<b>Field Observations:</b>			<b>Wetland Hydrology Present?</b> Yes <u>X</u> No _____
Surface Water Present?	Yes _____ No <u>X</u>	Depth (inches): _____	
Water Table Present?	Yes _____ No <u>X</u>	Depth (inches): _____	
Saturation Present? (includes capillary fringe)	Yes <u>X</u> No _____	Depth (inches): <u>0</u>	

Describe Recorded Data (stream gauge, monitoring well, aerial photos, previous inspections), if available:

Remarks:

**VEGETATION - Use scientific names of plants.**

Sampling Point: WET-A

Tree Stratum (Plot size: <u>30' radius</u> )	Absolute % Cover	Dominant Species?	Indicator Status
1. <i>Aesculus glabra</i>	20%	Yes	FAC
2. <i>Prunus serotina</i>	2%	No	FACU
3. <i>Platanus occidentalis</i>	15%	Yes	FACW
4. _____	_____	_____	_____
5. _____	_____	_____	_____
6. _____	_____	_____	_____
7. _____	_____	_____	_____
	37%	= Total Cover	

Sapling/Shrub Stratum: (Plot Size: <u>15' radius</u> )	Absolute % Cover	Dominant Species?	Indicator Status
1. <i>Rosa multiflora</i>	5%	Yes	FACU
2. <i>Aesculus glabra</i>	5%	Yes	FAC
3. <i>Prunus serotina</i>	2%	No	FACU
4. _____	_____	_____	_____
5. _____	_____	_____	_____
6. _____	_____	_____	_____
7. _____	_____	_____	_____
8. _____	_____	_____	_____
9. _____	_____	_____	_____
	12%	= Total Cover	

Herb Stratum: (Plot size: <u>5' radius</u> )	Absolute % Cover	Dominant Species?	Indicator Status
1. <i>Phalaris arundinacea</i>	55%	Yes	FACW
2. <i>Rosa multiflora</i>	2%	No	FACU
3. <i>Ranunculus hispidus</i>	25%	Yes	FAC
4. <i>Galium asprellum</i>	5%	No	OBL
5. _____	_____	_____	_____
6. _____	_____	_____	_____
7. _____	_____	_____	_____
8. _____	_____	_____	_____
9. _____	_____	_____	_____
10. _____	_____	_____	_____
11. _____	_____	_____	_____
12. _____	_____	_____	_____
13. _____	_____	_____	_____
14. _____	_____	_____	_____
15. _____	_____	_____	_____
16. _____	_____	_____	_____
17. _____	_____	_____	_____
18. _____	_____	_____	_____
19. _____	_____	_____	_____
	87%	= Total Cover	

Woody Vine Stratum: (Plot size: <u>30' radius</u> )	Absolute % Cover	Dominant Species?	Indicator Status
1. <i>Toxicodendron radicans</i>	7%	Yes	FAC
2. _____	_____	_____	_____
3. _____	_____	_____	_____
4. _____	_____	_____	_____
5. _____	_____	_____	_____
	7%	= Total Cover	

Remarks: (Include photo numbers here or on a separate sheet.)

**Dominance Test worksheet:**

Number of Dominant Species That Are OBL, FACW, or FAC: 6 (A)

Total Number of Dominant Species Across All Strata: 7 (B)

Percent of Dominant Species That Are OBL, FACW, or FAC: 86% (A/B)

**Prevalence Index worksheet:**

	Total % Cover of:	Multiply by:
OBL species	<u>5</u>	<u>1</u> = <u>5</u>
FACW species	<u>70</u>	<u>2</u> = <u>140</u>
FAC species	<u>57</u>	<u>3</u> = <u>171</u>
FACU species	<u>11</u>	<u>4</u> = <u>44</u>
UPL species	<u>0</u>	<u>5</u> = <u>0</u>
Column Totals:	<u>143</u> (A)	<u>360</u> (B)

Prevalence Index = B/A = 2.52

- Hydrophytic Vegetation Indicators:**
- 1 - Rapid Test for Hydrophytic Vegetation
  - 2 - Dominance Test is >50%
  - 3 - Prevalence Index is  $\leq 3.0^1$
  - 4 - Morphological Adaptations<sup>1</sup> (Provide supporting data in Remarks or on a separate sheet)
- \_\_\_\_\_ Problematic Hydrophytic Vegetation<sup>1</sup> (Explain)
- <sup>1</sup> Indicators of hydric soil and wetland hydrology must be present, unless disturbed or problematic.

**Definitions of Four Vegetation Strata:**

**Tree** - Woody plants, excluding vines, 3 in. (7.6 cm) or more in diameter at breast height (DBH), regardless of height.

**Sapling** - Woody plants, excluding woody vines, approximately 20 ft (6 m) or more in height and less than 3 in. (7.6 cm) DBH.

**Shrub** - Woody plants, excluding woody vines, approximately 3 to 20 ft (1 to 6 m) in height.

**Herb** - All herbaceous (non-woody) plants, regardless of size, and woody plants less than 3.28 ft tall.

**Woody Vines** - All woody vines greater than 3.28 ft in height.

**Hydrophytic Vegetation Present?** Yes  No \_\_\_\_\_



**SOIL**

Sampling Point: WET-A

Profile Description: (Describe to the depth needed to document the indicator or confirm the absence of indicators.)								
Depth (inches)	Matrix		Redox Features				Texture	Remarks
	Color (moist)	%	Color (moist)	%	Type <sup>1</sup>	Loc <sup>2</sup>		
0-3	10YR 3/1	100					Silty Clay Loam	
3-10	10YR 4/1	88	5YR 3/4	7	C	M	Silty Clay Loam	
			10YR 5/8	5	C	M	Silty Clay Loam	
10-17	10YR 5/2	90	10YR 5/8	10	C	M	Silty Clay Loam	

<sup>1</sup>Type: C=Concentration, D=Depletion, RM=Reduced Matrix, MS=Masked Sand Grains      <sup>2</sup>Location: PL=Pore Lining, M=Matrix

<b>Hydric Soil Indicators:</b>		<b>Indicators for Problematic Hydric Soils<sup>3</sup>:</b>	
<input type="checkbox"/> Histosol (A1)	<input type="checkbox"/> Polyvalue Below Surface (S8) (LRR R, MLRA 149B)	<input type="checkbox"/> 2 cm Muck (A10) (LRR K, L, MLRA 149B)	
<input type="checkbox"/> Histic Epipedon (A2)	<input type="checkbox"/> Thin Dark Surface (S9) (LRR R, MLRA 149B)	<input type="checkbox"/> Coast Prairie Redox (A16) (LLR K, L, R)	
<input type="checkbox"/> Black Histic (A3)	<input type="checkbox"/> Loamy Mucky Mineral (F1) (LRR K, L)	<input type="checkbox"/> 5 cm Mucky Peat or Peat (S3) (LLR K, L, R)	
<input type="checkbox"/> Hydrogen Sulfide (A4)	<input type="checkbox"/> Loamy Gleyed Matrix (F2)	<input type="checkbox"/> Dark Surface (S7) (LLR K, L, M)	
<input type="checkbox"/> Stratified Layers (A5)	<input type="checkbox"/> Depleted Matrix (F3)	<input type="checkbox"/> Polyvalue Below Surface (S9) (LLR K, L)	
<input type="checkbox"/> Depleted Below Dark Surface (A11)	<input checked="" type="checkbox"/> Redox Dark Surface (F6)	<input type="checkbox"/> Thin Dark Surface (S9) (LRR K, L)	
<input type="checkbox"/> Thick Dark Surface (A12)	<input type="checkbox"/> Depleted Dark Surface (F7)	<input type="checkbox"/> Iron-Manganese Masses (F12) (LLR K, L, R)	
<input type="checkbox"/> Sandy Mucky Mineral (S1)	<input type="checkbox"/> Redox Depressions (F8)	<input type="checkbox"/> Piedmont Floodplain Soils (F19) (MLRA 149B)	
<input type="checkbox"/> Sandy Gleyed Matrix (S4)		<input type="checkbox"/> Mesic Spodic (TA6) (MLRA 144A, 145, 149B)	
<input type="checkbox"/> Sandy Redox (S5)		<input type="checkbox"/> Red Parent Material (F21)	
<input type="checkbox"/> Stripped Matrix (S6)		<input type="checkbox"/> Very Shallow Dark Surface (TF12)	
<input type="checkbox"/> Dark Surface (S7) (LRR R, MLRA 149B)		<input type="checkbox"/> Other (Explain in Remarks)	

<sup>3</sup>Indicators of hydrophytic vegetation and wetland hydrology must be present, unless disturbed or problematic.

<b>Restrictive Layer (if observed):</b>		<b>Hydric Soil Present?</b> Yes <input checked="" type="checkbox"/> No <input type="checkbox"/>
Type: _____	Depth (inches): _____	

Remarks:

**WETLAND DETERMINATION DATA FORM - Northcentral and Northeast Region**

Project/Site: PIR 2788 City/County: Wayne County Sampling Date: May 13, 2020  
 Applicant/Owner: DEO State: Ohio Sampling Point: UP-A  
 Investigator(s): K. SIMON Section, Township, Range: S2 T15 R13W  
 Landform (hillslope, terrace, etc.): \_\_\_\_\_ Local Relief (concave, convex, none): \_\_\_\_\_ Slope (%): \_\_\_\_\_  
 Subregion (LRR or MLRA): LRR R Lat: 40.80354 Long: -81.89829 Datum: NAD83  
 Soil Map Unit Name: Tg - Tioga silt loam, occasionally flooded NWI classification: None  
 Are climatic/hydrologic conditions on the site typical for this time of year? Yes X No \_\_\_\_\_ (If no, explain in Remarks.)  
 Are Vegetation No, Soil No, or Hydrology No significantly disturbed? Are "Normal Circumstances" present?  
 Yes X No \_\_\_\_\_  
 Are Vegetation No, Soil No, or Hydrology No naturally problematic? (If needed, explain any answers in Remarks.)

**SUMMARY OF FINDINGS - Attach site map showing sampling point locations, transects, important features, etc.**

Hydrophytic Vegetation Present?	Yes _____	No <u>X</u>	Is the Sampled Area within a Wetland? Yes _____ No <u>X</u> If yes, optional Wetland Site ID: _____
Hydric Soil Present?	Yes _____	No <u>X</u>	
Wetland Hydrology Present?	Yes _____	No <u>X</u>	
Remarks:			

**HYDROLOGY**

Wetland Hydrology Indicators:	Secondary Indicators (minimum of two required)
Primary Indicators (minimum of one is required; check all that apply)	
<input type="checkbox"/> Surface Water (A1)	<input type="checkbox"/> Surface Soil Cracks (B6)
<input type="checkbox"/> High Water Table (A2)	<input type="checkbox"/> Drainage Patterns (B10)
<input type="checkbox"/> Saturation (A3)	<input type="checkbox"/> Moss Trim Lines (B16)
<input type="checkbox"/> Water Marks (B1)	<input type="checkbox"/> Dry-Season Water Table (C2)
<input type="checkbox"/> Sediment Deposits (B2)	<input type="checkbox"/> Crayfish Burrows (C8)
<input type="checkbox"/> Drift Deposits (B3)	<input type="checkbox"/> Saturation Visible on Aerial Imagery (C9)
<input type="checkbox"/> Algal Mat or Crust (B4)	<input type="checkbox"/> Stunted or Stressed Plants (D1)
<input type="checkbox"/> Iron Deposits (B5)	<input checked="" type="checkbox"/> Geomorphic Position (D2)
<input type="checkbox"/> Inundation Visible on Aerial Imagery (B7)	<input type="checkbox"/> Shallow Aquitard (D3)
<input type="checkbox"/> Sparsely Vegetated Concave Surface (B8)	<input type="checkbox"/> Microtopographic Relief (D4)
<input type="checkbox"/> Water-Stained Leaves (B9)	<input type="checkbox"/> FAC-Neutral Test (D5)
<input type="checkbox"/> Aquatic Fauna (B13)	
<input type="checkbox"/> Marl Deposits (B15)	
<input type="checkbox"/> Hydrogen Sulfide Odor (C1)	
<input type="checkbox"/> Oxidized Rhizospheres on Living Roots (C3)	
<input type="checkbox"/> Presence of Reduced Iron (C4)	
<input type="checkbox"/> Recent Iron Reduction in Tilled Soils (C6)	
<input type="checkbox"/> Thin Muck Surface (C7)	
<input type="checkbox"/> Other (Explain in Remarks)	

<b>Field Observations:</b> Surface Water Present? Yes _____ No <u>X</u> Depth (inches): _____ Water Table Present? Yes _____ No <u>X</u> Depth (inches): _____ Saturation Present? Yes _____ No <u>X</u> Depth (inches): _____ (includes capillary fringe)	<b>Wetland Hydrology Present?</b> Yes _____ No <u>X</u>
--	--

Describe Recorded Data (stream gauge, monitoring well, aerial photos, previous inspections), if available:

Remarks:

**VEGETATION - Use scientific names of plants.**

Sampling Point: UP-A

Tree Stratum (Plot size: <u>30' radius</u> )	Absolute % Cover	Dominant Species?	Indicator Status
1. <i>None observed</i>			
2.			
3.			
4.			
5.			
6.			
7.			
0% = Total Cover			

Sapling/Shrub Stratum: (Plot Size: <u>15' radius</u> )	Absolute % Cover	Dominant Species?	Indicator Status
1. <i>Rubus idaeus</i>	30%	Yes	FACU
2. <i>Plantains occidentalis</i>	2%	No	FACU
3.			
4.			
5.			
6.			
7.			
8.			
9.			
32% = Total Cover			

Herb Stratum: (Plot size: <u>5' radius</u> )	Absolute % Cover	Dominant Species?	Indicator Status
1. <i>Phalaris arundinacea</i>	10%	No	FACW
2. <i>Glechoma hederacea</i>	5%	No	FACU
3. <i>Conium maculatum</i>	5%	No	FACW
4. <i>Digitaria ischaemum</i>	5%	No	FACU
5. <i>Arenaria serpyllifolia</i>	80%	Yes	FAC
6.			
7.			
8.			
9.			
10.			
11.			
12.			
13.			
14.			
15.			
16.			
17.			
18.			
19.			
105% = Total Cover			

Woody Vine Stratum: (Plot size: <u>30' radius</u> )	Absolute % Cover	Dominant Species?	Indicator Status
1. <i>None observed</i>			
2.			
3.			
4.			
5.			
0% = Total Cover			

**Dominance Test worksheet:**

Number of Dominant Species That Are OBL, FACW, or FAC: 1 (A)

Total Number of Dominant Species Across All Strata: 2 (B)

Percent of Dominant Species That Are OBL, FACW, or FAC: 50% (A/B)

**Prevalence Index worksheet:**

	Total % Cover of:	Multiply by:	
OBL species	<u>0</u>	x 1 =	<u>0</u>
FACW species	<u>15</u>	x 2 =	<u>30</u>
FAC species	<u>80</u>	x 3 =	<u>240</u>
FACU species	<u>42</u>	x 4 =	<u>168</u>
UPL species	<u>0</u>	x 5 =	<u>0</u>
Column Totals:	<u>137</u> (A)		<u>438</u> (B)

Prevalence Index = B/A = 3.20

**Hydrophytic Vegetation Indicators:**

         1 - Rapid Test for Hydrophytic Vegetation

         2 - Dominance Test is >50%

         3 - Prevalence Index is  $\leq 3.0^1$

         4 - Morphological Adaptations<sup>1</sup> (Provide supporting data in Remarks or on a separate sheet)

         Problematic Hydrophytic Vegetation<sup>1</sup> (Explain)

<sup>1</sup> Indicators of hydric soil and wetland hydrology must be present, unless disturbed or problematic.

**Definitions of Four Vegetation Strata:**

**Tree** - Woody plants, excluding vines, 3 in. (7.6 cm) or more in diameter at breast height (DBH), regardless of height.

**Sapling** - Woody plants, excluding woody vines, approximately 20 ft (6 m) or more in height and less than 3 in. (7.6 cm) DBH.

**Shrub** - Woody plants, excluding woody vines, approximately 3 to 20 ft (1 to 6 m) in height.

**Herb** - All herbaceous (non-woody) plants, regardless of size, and woody plants less than 3.28 ft tall.

**Woody Vines** - All woody vines greater than 3.28 ft in height.

**Hydrophytic Vegetation Present?**      Yes               No   X  

Remarks: (Include photo numbers here or on a separate sheet.)





**WETLAND DETERMINATION DATA FORM – Northcentral and Northeast Region**

Project/Site: PIR 2788 City/County: Wayne County Sampling Date: 2021-04-30  
 Applicant/Owner: DEO State: Ohio Sampling Point: WET-A2  
 Investigator(s): A. Dietz-Oergel Section, Township, Range: Wooster Township  
 Landform (hillslope, terrace, etc.): Floodplain Local relief (concave, convex, none): None Slope (%): 0  
 Subregion (LRR or MLRA): R Lat: 40.8015442 Long: -81.9016756 Datum: NAD 83  
 Soil Map Unit Name: \_\_\_\_\_ NWI classification: PFO

Are climatic / hydrologic conditions on the site typical for this time of year? Yes  No \_\_\_\_\_ (If no, explain in Remarks.)  
 Are Vegetation \_\_\_\_\_, Soil \_\_\_\_\_, or Hydrology  significantly disturbed? Are "Normal Circumstances" present? Yes  No \_\_\_\_\_  
 Are Vegetation \_\_\_\_\_, Soil \_\_\_\_\_, or Hydrology \_\_\_\_\_ naturally problematic? (If needed, explain any answers in Remarks.)

**SUMMARY OF FINDINGS – Attach site map showing sampling point locations, transects, important features, etc.**

Hydrophytic Vegetation Present? Yes <input checked="" type="checkbox"/> No _____ Hydric Soil Present? Yes <input checked="" type="checkbox"/> No _____ Wetland Hydrology Present? Yes <input checked="" type="checkbox"/> No _____	<b>Is the Sampled Area within a Wetland?</b> Yes <input checked="" type="checkbox"/> No _____ If yes, optional Wetland Site ID: _____
Remarks: (Explain alternative procedures here or in a separate report.)    	

**HYDROLOGY**

<b>Wetland Hydrology Indicators:</b> <u>Primary Indicators (minimum of one is required; check all that apply)</u> ___ Surface Water (A1)      ___ Water-Stained Leaves (B9) ___ High Water Table (A2)      ___ Aquatic Fauna (B13) ___ Saturation (A3)      ___ Marl Deposits (B15) ___ Water Marks (B1)      ___ Hydrogen Sulfide Odor (C1) ___ Sediment Deposits (B2)      ___ Oxidized Rhizospheres on Living Roots (C3) ___ Drift Deposits (B3)      ___ Presence of Reduced Iron (C4) ___ Algal Mat or Crust (B4)      ___ Recent Iron Reduction in Tilled Soils (C6) ___ Iron Deposits (B5)      ___ Thin Muck Surface (C7) ___ Inundation Visible on Aerial Imagery (B7)      ___ Other (Explain in Remarks) ___ Sparsely Vegetated Concave Surface (B8)	<u>Secondary Indicators (minimum of two required)</u> ___ Surface Soil Cracks (B6) ___ Drainage Patterns (B10) ___ Moss Trim Lines (B16) ___ Dry-Season Water Table (C2) ___ Crayfish Burrows (C8) ___ Saturation Visible on Aerial Imagery (C9) ___ Stunted or Stressed Plants (D1) <input checked="" type="checkbox"/> Geomorphic Position (D2) ___ Shallow Aquitard (D3) ___ Microtopographic Relief (D4) <input checked="" type="checkbox"/> FAC-Neutral Test (D5)
<b>Field Observations:</b> Surface Water Present? Yes _____ No <input checked="" type="checkbox"/> Depth (inches): _____ Water Table Present? Yes _____ No <input checked="" type="checkbox"/> Depth (inches): _____ Saturation Present? Yes _____ No <input checked="" type="checkbox"/> Depth (inches): _____ (includes capillary fringe)	<b>Wetland Hydrology Present?</b> Yes <input checked="" type="checkbox"/> No _____
Describe Recorded Data (stream gauge, monitoring well, aerial photos, previous inspections), if available:  	
Remarks:	

**VEGETATION – Use scientific names of plants.**

Sampling Point: WET-A2

Tree Stratum (Plot size: <u>30 ft r</u> )	Absolute % Cover	Dominant Species?	Indicator Status															
1. <u>Populus deltoides</u>	<u>50</u>	<input checked="" type="checkbox"/>	<u>FAC</u>	<b>Dominance Test worksheet:</b> Number of Dominant Species That Are OBL, FACW, or FAC: <u>5</u> (A)  Total Number of Dominant Species Across All Strata: <u>5</u> (B)  Percent of Dominant Species That Are OBL, FACW, or FAC: <u>100</u> (A/B)														
2. <u>Acer rubrum</u>	<u>25</u>	<input checked="" type="checkbox"/>	<u>FAC</u>															
3. <u>Aesculus glabra</u>	<u>20</u>		<u>FAC</u>															
4. <u>Fraxinus pennsylvanica</u>	<u>15</u>		<u>FACW</u>															
5. _____																		
6. _____																		
7. _____																		
<u>110%</u> = Total Cover				<b>Prevalence Index worksheet:</b> <table style="width:100%; border:none;"> <tr> <td style="width:50%; text-align:right;">Total % Cover of:</td> <td style="width:50%; text-align:left;">Multiply by:</td> </tr> <tr> <td>OBL species <u>0</u></td> <td>x 1 = <u>0</u></td> </tr> <tr> <td>FACW species <u>65</u></td> <td>x 2 = <u>130</u></td> </tr> <tr> <td>FAC species <u>135</u></td> <td>x 3 = <u>405</u></td> </tr> <tr> <td>FACU species <u>4</u></td> <td>x 4 = <u>16</u></td> </tr> <tr> <td>UPL species <u>0</u></td> <td>x 5 = <u>0</u></td> </tr> <tr> <td>Column Totals: <u>204</u> (A)</td> <td><u>551</u> (B)</td> </tr> </table> Prevalence Index = B/A = <u>2.7</u>	Total % Cover of:	Multiply by:	OBL species <u>0</u>	x 1 = <u>0</u>	FACW species <u>65</u>	x 2 = <u>130</u>	FAC species <u>135</u>	x 3 = <u>405</u>	FACU species <u>4</u>	x 4 = <u>16</u>	UPL species <u>0</u>	x 5 = <u>0</u>	Column Totals: <u>204</u> (A)	<u>551</u> (B)
Total % Cover of:	Multiply by:																	
OBL species <u>0</u>	x 1 = <u>0</u>																	
FACW species <u>65</u>	x 2 = <u>130</u>																	
FAC species <u>135</u>	x 3 = <u>405</u>																	
FACU species <u>4</u>	x 4 = <u>16</u>																	
UPL species <u>0</u>	x 5 = <u>0</u>																	
Column Totals: <u>204</u> (A)	<u>551</u> (B)																	
<u>20%</u> = Total Cover																		
<b>Sapling/Shrub Stratum (Plot size: <u>15 ft r</u> )</b>																		
1. <u>Aesculus glabra</u>	<u>20</u>	<input checked="" type="checkbox"/>	<u>FAC</u>															
2. _____																		
3. _____																		
4. _____																		
5. _____																		
6. _____																		
7. _____																		
<u>20%</u> = Total Cover																		
<b>Herb Stratum (Plot size: <u>5 ft r</u> )</b>																		
1. <u>Elymus virginicus</u>	<u>50</u>	<input checked="" type="checkbox"/>	<u>FACW</u>															
2. <u>Ranunculus repens</u>	<u>20</u>	<input checked="" type="checkbox"/>	<u>FAC</u>															
3. <u>Viola sp.</u>	<u>10</u>																	
4. <u>Galium aparine</u>	<u>2</u>		<u>FACU</u>															
5. <u>Rosa multiflora</u>	<u>2</u>		<u>FACU</u>															
6. _____																		
7. _____																		
8. _____																		
9. _____																		
10. _____																		
11. _____																		
12. _____																		
<u>84%</u> = Total Cover																		
<b>Woody Vine Stratum (Plot size: <u>30 ft r</u> )</b>																		
1. _____																		
2. _____																		
3. _____																		
4. _____																		
_____ = Total Cover																		
<b>Hydrophytic Vegetation Present?</b> Yes <input checked="" type="checkbox"/> No _____																		
				1Indicators of hydric soil and wetland hydrology must be present, unless disturbed or problematic.														
<b>Definitions of Vegetation Strata:</b> <b>Tree</b> – Woody plants 3 in. (7.6 cm) or more in diameter at breast height (DBH), regardless of height. <b>Sapling/shrub</b> – Woody plants less than 3 in. DBH and greater than or equal to 3.28 ft (1 m) tall. <b>Herb</b> – All herbaceous (non-woody) plants, regardless of size, and woody plants less than 3.28 ft tall. <b>Woody vines</b> – All woody vines greater than 3.28 ft in height.																		
Remarks: (Include photo numbers here or on a separate sheet.)																		



**SOIL**

Sampling Point: WET-A2

**Profile Description: (Describe to the depth needed to document the indicator or confirm the absence of indicators.)**

Depth (inches)	Matrix		Redox Features				Texture	Remarks
	Color (moist)	%	Color (moist)	%	Type <sup>1</sup>	Loc <sup>2</sup>		
0 - 8	10YR 4/3	100					Sand	
8 - 13	10YR 3/2	80	10YR 5/8	20	C	M	Sandy Loam	
13 - 20	10YR 4/4	100					Sandy Loam	
-								
-								
-								
-								
-								
-								
-								
-								
-								
-								

<sup>1</sup>Type: C=Concentration, D=Depletion, RM=Reduced Matrix, MS=Masked Sand Grains.

<sup>2</sup>Location: PL=Pore Lining, M=Matrix.

**Hydric Soil Indicators:**

- Histosol (A1)
- Histic Epipedon (A2)
- Black Histic (A3)
- Hydrogen Sulfide (A4)
- Stratified Layers (A5)
- Depleted Below Dark Surface (A11)
- Thick Dark Surface (A12)
- Sandy Mucky Mineral (S1)
- Sandy Gleyed Matrix (S4)
- Sandy Redox (S5)
- Stripped Matrix (S6)
- Dark Surface (S7) (LRR R, MLRA 149B)
- Polyvalue Below Surface (S8) (LRR R, MLRA 149B)
- Thin Dark Surface (S9) (LRR R, MLRA 149B)
- Loamy Mucky Mineral (F1) (LRR K, L)
- Loamy Gleyed Matrix (F2)
- Depleted Matrix (F3)
- Redox Dark Surface (F6)
- Depleted Dark Surface (F7)
- Redox Depressions (F8)

**Indicators for Problematic Hydric Soils<sup>3</sup>:**

- 2 cm Muck (A10) (LRR K, L, MLRA 149B)
- Coast Prairie Redox (A16) (LRR K, L, R)
- 5 cm Mucky Peat or Peat (S3) (LRR K, L, R)
- Dark Surface (S7) (LRR K, L)
- Polyvalue Below Surface (S8) (LRR K, L)
- Thin Dark Surface (S9) (LRR K, L)
- Iron-Manganese Masses (F12) (LRR K, L, R)
- Piedmont Floodplain Soils (F19) (MLRA 149B)
- Mesic Spodic (TA6) (MLRA 144A, 145, 149B)
- Red Parent Material (F21)
- Very Shallow Dark Surface (TF12)
- Other (Explain in Remarks)

<sup>3</sup>Indicators of hydrophytic vegetation and wetland hydrology must be present, unless disturbed or problematic.

**Restrictive Layer (if observed):**

Type: \_\_\_\_\_  
 Depth (inches): \_\_\_\_\_

Hydric Soil Present? Yes  No

Remarks:

**WETLAND DETERMINATION DATA FORM – Northcentral and Northeast Region**

Project/Site: PIR 2788 City/County: Wayne County Sampling Date: 2021-04-30  
 Applicant/Owner: DEO State: Ohio Sampling Point: UP-A2  
 Investigator(s): A. Dietz-Oergel Section, Township, Range: Wooster Township  
 Landform (hillslope, terrace, etc.): Upland, Flat Local relief (concave, convex, none): None Slope (%): 0  
 Subregion (LRR or MLRA): R Lat: 40.8062134 Long: -81.9010237 Datum: NAD 83  
 Soil Map Unit Name: \_\_\_\_\_ NWI classification: \_\_\_\_\_

Are climatic / hydrologic conditions on the site typical for this time of year? Yes  No \_\_\_\_\_ (If no, explain in Remarks.)  
 Are Vegetation \_\_\_\_\_, Soil \_\_\_\_\_, or Hydrology \_\_\_\_\_ significantly disturbed? Are "Normal Circumstances" present? Yes  No \_\_\_\_\_  
 Are Vegetation \_\_\_\_\_, Soil \_\_\_\_\_, or Hydrology \_\_\_\_\_ naturally problematic? (If needed, explain any answers in Remarks.)

**SUMMARY OF FINDINGS – Attach site map showing sampling point locations, transects, important features, etc.**

Hydrophytic Vegetation Present? Yes _____ No <input checked="" type="checkbox"/> Hydric Soil Present? Yes _____ No <input checked="" type="checkbox"/> Wetland Hydrology Present? Yes _____ No <input checked="" type="checkbox"/>	<b>Is the Sampled Area within a Wetland?</b> Yes _____ No <input checked="" type="checkbox"/> If yes, optional Wetland Site ID: _____
Remarks: (Explain alternative procedures here or in a separate report.)	

**HYDROLOGY**

<b>Wetland Hydrology Indicators:</b> <u>Primary Indicators (minimum of one is required; check all that apply)</u> ___ Surface Water (A1)      ___ Water-Stained Leaves (B9) ___ High Water Table (A2)      ___ Aquatic Fauna (B13) ___ Saturation (A3)      ___ Marl Deposits (B15) ___ Water Marks (B1)      ___ Hydrogen Sulfide Odor (C1) ___ Sediment Deposits (B2)      ___ Oxidized Rhizospheres on Living Roots (C3) ___ Drift Deposits (B3)      ___ Presence of Reduced Iron (C4) ___ Algal Mat or Crust (B4)      ___ Recent Iron Reduction in Tilled Soils (C6) ___ Iron Deposits (B5)      ___ Thin Muck Surface (C7) ___ Inundation Visible on Aerial Imagery (B7)      ___ Other (Explain in Remarks) ___ Sparsely Vegetated Concave Surface (B8)	<u>Secondary Indicators (minimum of two required)</u> ___ Surface Soil Cracks (B6) ___ Drainage Patterns (B10) ___ Moss Trim Lines (B16) ___ Dry-Season Water Table (C2) ___ Crayfish Burrows (C8) ___ Saturation Visible on Aerial Imagery (C9) ___ Stunted or Stressed Plants (D1) ___ Geomorphic Position (D2) ___ Shallow Aquitard (D3) ___ Microtopographic Relief (D4) ___ FAC-Neutral Test (D5)
<b>Field Observations:</b> Surface Water Present? Yes _____ No <input checked="" type="checkbox"/> Depth (inches): _____ Water Table Present? Yes _____ No <input checked="" type="checkbox"/> Depth (inches): _____ Saturation Present? Yes _____ No <input checked="" type="checkbox"/> Depth (inches): _____ (includes capillary fringe)	<b>Wetland Hydrology Present?</b> Yes _____ No <input checked="" type="checkbox"/>
Describe Recorded Data (stream gauge, monitoring well, aerial photos, previous inspections), if available:  Remarks:	

**VEGETATION** – Use scientific names of plants.

Sampling Point: UP-A2

	Absolute % Cover	Dominant Species?	Indicator Status	
<b>Tree Stratum</b> (Plot size: <u>30 ft r</u> )				
1.				
2.				
3.				
4.				
5.				
6.				
7.				
	_____ = Total Cover			
<b>Sapling/Shrub Stratum</b> (Plot size: <u>15 ft r</u> )				
1.				
2.				
3.				
4.				
5.				
6.				
7.				
	_____ = Total Cover			
<b>Herb Stratum</b> (Plot size: <u>5 ft r</u> )				
1. <u>Phleum pratense</u>	<u>80</u>	<input checked="" type="checkbox"/>	<u>FACU</u>	
2. <u>Taraxacum officinale</u>	<u>15</u>		<u>FACU</u>	
3. <u>Trifolium pratense</u>	<u>5</u>		<u>FACU</u>	
4.				
5.				
6.				
7.				
8.				
9.				
10.				
11.				
12.				
	<u>100%</u> = Total Cover			
<b>Woody Vine Stratum</b> (Plot size: <u>30 ft r</u> )				
1.				
2.				
3.				
4.				
	_____ = Total Cover			
<p>Remarks: (Include photo numbers here or on a separate sheet.)</p>				

**Dominance Test worksheet:**

Number of Dominant Species That Are OBL, FACW, or FAC: 0 (A)

Total Number of Dominant Species Across All Strata: 1 (B)

Percent of Dominant Species That Are OBL, FACW, or FAC: 0 (A/B)

---

**Prevalence Index worksheet:**

	Total % Cover of:	Multiply by:
OBL species	<u>0</u>	x 1 = <u>0</u>
FACW species	<u>0</u>	x 2 = <u>0</u>
FAC species	<u>0</u>	x 3 = <u>0</u>
FACU species	<u>100</u>	x 4 = <u>400</u>
UPL species	<u>0</u>	x 5 = <u>0</u>
Column Totals:	<u>100</u> (A)	<u>400</u> (B)

Prevalence Index = B/A = 4.0

---

**Hydrophytic Vegetation Indicators:**

1 - Rapid Test for Hydrophytic Vegetation

2 - Dominance Test is >50%

3 - Prevalence Index is ≤3.0<sup>1</sup>

4 - Morphological Adaptations<sup>1</sup> (Provide supporting data in Remarks or on a separate sheet)

Problematic Hydrophytic Vegetation<sup>1</sup> (Explain)

<sup>1</sup>Indicators of hydric soil and wetland hydrology must be present, unless disturbed or problematic.

---

**Definitions of Vegetation Strata:**

**Tree** – Woody plants 3 in. (7.6 cm) or more in diameter at breast height (DBH), regardless of height.

**Sapling/shrub** – Woody plants less than 3 in. DBH and greater than or equal to 3.28 ft (1 m) tall.

**Herb** – All herbaceous (non-woody) plants, regardless of size, and woody plants less than 3.28 ft tall.

**Woody vines** – All woody vines greater than 3.28 ft in height.

---

**Hydrophytic Vegetation Present?**      Yes \_\_\_\_\_ No





## Appendix C Ohio Rapid Assessment Method (ORAM) Dataforms

## Background Information

<b>Name:</b> A. Dietz-Oergel, K. Simon	
<b>Date:</b> 05/21/2020	
<b>Affiliation:</b> Environmental Consulting & Technology, Inc	
<b>Address:</b> 161 E Aurora Rd. Northfield OH 44067	
<b>Phone Number:</b> (216) 518-2807	
<b>e-mail address:</b> adietz-oergel@ectinc.com	
<b>Name of Wetland:</b> Wetland A	
<b>Vegetation Communit(ies):</b> PEM PSS PFO	
<b>HGM Class(es):</b> Depressional Riverine Slope	
<b>Location of Wetland: include map, address, north arrow, landmarks, distances, roads, etc.</b> See attached delineation report	
Lat/Long or UTM Coordinate	40.803276, -81.898818
USGS Quad Name	Wooster Quad.
County	Wayne County
Township	Wooster Twp.
Section and Subsection	S2
Hydrologic Unit Code	05040003
Site Visit	May 13, 2020
National Wetland Inventory Map	See attached
Ohio Wetland Inventory Map	N/A
Soil Survey	See attached
Delineation report/map	See attached Delineation Report.



<b>Name of Wetland:</b> Wetland A	
<b>Wetland Size (acres, hectares):</b> 3.00+	
<b>Sketch: Include north arrow, relationship with other surface waters, vegetation zones, etc.</b> See Attached.	
<b>Comments, Narrative Discussion, Justification of Category Changes:</b>	
<b>Final score :</b> 49	<b>Category:</b> 2

## Scoring Boundary Worksheet

INSTRUCTIONS. The initial step in completing the ORAM is to identify the “scoring boundaries” of the wetland being rated. In many instances this determination will be relatively easy and the scoring boundaries will coincide with the “jurisdictional boundaries.” For example, the scoring boundary of an isolated cattail marsh located in the middle of a farm field will likely be the same as that wetland’s jurisdictional boundaries. In other instances, however, the scoring boundary will not be as easily determined. Wetlands that are small or isolated from other surface waters often form large contiguous areas or heterogeneous complexes of wetland and upland. In separating wetlands for scoring purposes, the hydrologic regime of the wetland is the main criterion that should be used. Boundaries between contiguous or connected wetlands should be established where the volume, flow, or velocity of water moving through the wetland changes significantly. *Areas with a high degree of hydrologic interaction should be scored as a single wetland.* In determining a wetland’s scoring boundaries, use the guidelines in the ORAM Manual Section 5.0. In certain instances, it may be difficult to establish the scoring boundary for the wetland being rated. These problem situations include wetlands that form a patchwork on the landscape, wetlands divided by artificial boundaries like property fences, roads, or railroad embankments, wetlands that are contiguous with streams, lakes, or rivers, and estuarine or coastal wetlands. These situations are discussed below, however, it is recommended that Rater contact Ohio EPA, Division of Surface Water, 401/Wetlands Section if there are additional questions or a need for further clarification of the appropriate scoring boundaries of a particular wetland.

#	Steps in properly establishing scoring boundaries	done?	not applicable
<b>Step 1</b>	Identify the wetland area of interest. This may be the site of a proposed impact, a reference site, conservation site, etc.	✓	
<b>Step 2</b>	Identify the locations where there is physical evidence that hydrology changes rapidly. Such evidence includes both natural and human-induced changes including, constrictions caused by berms or dikes, points where the water velocity changes rapidly at rapids or falls, points where significant inflows occur at the confluence of rivers, or other factors that may restrict hydrologic interaction between the wetlands or parts of a single wetland.	✓	
<b>Step 3</b>	Delineate the boundary of the wetland to be rated such that all areas of interest that are contiguous to and within the areas where the hydrology does not change significantly, i.e. areas that have a high degree of hydrologic interaction are included within the scoring boundary.	✓	
<b>Step 4</b>	Determine if artificial boundaries, such as property lines, state lines, roads, railroad embankments, etc., are present. These should not be used to establish scoring boundaries unless they coincide with areas where the hydrologic regime changes.	✓	
<b>Step 5</b>	In all instances, the Rater may enlarge the minimum scoring boundaries discussed here to score together wetlands that could be scored separately.	✓	
<b>Step 6</b>	Consult ORAM Manual Section 5.0 for how to establish scoring boundaries for wetlands that form a patchwork on the landscape, divided by artificial boundaries, contiguous to streams, lakes or rivers, or for dual classifications.	✓	

**End of Scoring Boundary Determination. Begin Narrative Rating on next page.**

## Narrative Rating

INSTRUCTIONS. Answer each of the following questions. Questions 1, 2, 3 and 4 should be answered based on information obtained from the site visit or the literature *and* by submitting a Data Services Request to the Ohio Department of Natural Resources, Division of Natural Areas and Preserves, Natural Heritage Data Services, 1889 Fountain Square Court, Building F-1, Columbus, Ohio 43224, 614-265-6453 (phone), 614-265-3096 (fax), <http://www.dnr.state.oh.us/dnap>. The remaining questions are designed to be answered primarily by the results of the site visit. Refer to the User's Manual for descriptions of these wetland types. Note: "Critical habitat" is legally defined in the Endangered Species Act and is the geographic area containing physical or biological features essential to the conservation of a listed species or as an area that may require special management considerations or protection. The Rater should contact the Region 3 Headquarters or the Columbus Ecological Services Office for updates as to whether critical habitat has been designated for other federally listed threatened or endangered species. "Documented" means the wetland is listed in the appropriate State of Ohio database.

#	Question	Circle one	
1	<b>Critical Habitat.</b> Is the wetland in a township, section, or subsection of a United States Geological Survey 7.5 minute Quadrangle that has been designated by the U.S. Fish and Wildlife Service as "critical habitat" for any threatened or endangered plant or animal species? Note: as of January 1, 2001, of the federally listed endangered or threatened species which can be found in Ohio, the Indiana Bat has had critical habitat designated (50 CFR 17.95(a)) and the piping plover has had critical habitat proposed (65 FR 41812 July 6, 2000).	YES  Wetland should be evaluated for possible Category 3 status  Go to Question 2	NO ✓  Go to Question 2
2	<b>Threatened or Endangered Species.</b> Is the wetland known to contain an individual of, or documented occurrences of federal or state-listed threatened or endangered plant or animal species?	YES  Wetland is a Category 3 wetland.  Go to Question 3	NO ✓  Go to Question 3
3	<b>Documented High Quality Wetland.</b> Is the wetland on record in Natural Heritage Database as a high quality wetland?	YES  Wetland is a Category 3 wetland  Go to Question 4	NO ✓  Go to Question 4
4	<b>Significant Breeding or Concentration Area.</b> Does the wetland contain documented regionally significant breeding or nonbreeding waterfowl, neotropical songbird, or shorebird concentration areas?	YES  Wetland is a Category 3 wetland  Go to Question 5	NO ✓  Go to Question 5
5	<b>Category 1 Wetlands.</b> Is the wetland less than 0.5 hectares (1 acre) in size and <b>hydrologically isolated</b> and either 1) comprised of vegetation that is dominated (greater than eighty per cent areal cover) by <i>Phalaris arundinacea</i> , <i>Lythrum salicaria</i> , or <i>Phragmites australis</i> , or 2) an acidic pond created or excavated on mined lands that has little or no vegetation?	YES  Wetland is a Category 1 wetland  Go to Question 6	NO ✓  Go to Question 6
6	<b>Bogs.</b> Is the wetland a peat-accumulating wetland that 1) has no significant inflows or outflows, 2) supports acidophilic mosses, particularly <i>Sphagnum</i> spp., 3) the acidophilic mosses have >30% cover, 4) at least one species from Table 1 is present, and 5) the cover of invasive species (see Table 1) is <25%?	YES  Wetland is a Category 3 wetland  Go to Question 7	NO ✓  Go to Question 7
7	<b>Fens.</b> Is the wetland a carbon accumulating (peat, muck) wetland that is saturated during most of the year, primarily by a discharge of free flowing, mineral rich, ground water with a circumneutral ph (5.5-9.0) and with one or more plant species listed in Table 1 and the cover of invasive species listed in Table 1 is <25%?	YES  Wetland is a Category 3 wetland  Go to Question 8a	NO ✓  Go to Question 8a
8a	<b>"Old Growth Forest."</b> Is the wetland a forested wetland and is the forest characterized by, but not limited to, the following characteristics: overstory canopy trees of great age (exceeding at least 50% of a projected maximum attainable age for a species); little or no evidence of human-caused understory disturbance during the past 80 to 100 years; an all-aged structure and multilayered canopies; aggregations of canopy trees interspersed with canopy gaps; and significant numbers of standing dead snags and downed logs?	YES  Wetland is a Category 3 wetland.  Go to Question 8b	NO ✓  Go to Question 8b



<b>8b</b>	<b>Mature forested wetlands.</b> Is the wetland a forested wetland with 50% or more of the cover of upper forest canopy consisting of deciduous trees with large diameters at breast height (dbh), generally diameters greater than 45cm (17.7in) dbh?	YES  Wetland should be evaluated for possible Category 3 status.  Go to Question 9a	NO ✓ Go to Question 9a
<b>9a</b>	<b>Lake Erie coastal and tributary wetlands.</b> Is the wetland located at an elevation less than 575 feet on the USGS map, adjacent to this elevation, or along a tributary to Lake Erie that is accessible to fish?	YES  Go to Question 9b	NO ✓ Go to Question 10
<b>9b</b>	Does the wetland's hydrology result from measures designed to prevent erosion and the loss of aquatic plants, i.e. the wetland is partially hydrologically restricted from Lake Erie due to lakeward or landward dikes or other hydrological controls?	YES  Wetland should be evaluated for possible Category 3 status  Go to Question 10	NO ✓ Go to Question 9c
<b>9c</b>	Are Lake Erie water levels the wetland's primary hydrological influence, i.e. the wetland is hydrologically unrestricted (no lakeward or upland border alterations), or the wetland can be characterized as an "estuarine" wetland with lake and river influenced hydrology. These include sandbar deposition wetlands, estuarine wetlands, river mouth wetlands, or those dominated by submersed aquatic vegetation.	YES  Go to Question 9d	NO ✓ Go to Question 10
<b>9d</b>	Does the wetland have a predominance of native species within its vegetation communities, although non-native or disturbance tolerant native species can also be present?	YES  Wetland is a Category 3 wetland  Go to Question 10	NO ✓ Go to Question 9e
<b>9e</b>	Does the wetland have a predominance of non-native or disturbance tolerant native plant species within its vegetation communities?	YES  Wetland should be evaluated for possible Category 3 status  Go to Question 10	NO ✓ Go to Question 10
<b>10</b>	<b>Lake Plain Sand Prairies (Oak Openings)</b> Is the wetland located in Lucas, Fulton, Henry, or Wood Counties and can the wetland be characterized by the following description: the wetland has a sandy substrate with interspersed organic matter, a water table often within several inches of the surface, and often with a dominance of the gramineous vegetation listed in Table 1 (woody species may also be present). The Ohio Department of Natural Resources Division of Natural Areas and Preserves can provide assistance in confirming this type of wetland and its quality.	YES  Wetland is a Category 3 wetland.  Go to Question 11	NO ✓ Go to Question 11
<b>11</b>	<b>Relict Wet Prairies.</b> Is the wetland a relict wet prairie community dominated by some or all of the species in Table 1. Extensive prairies were formerly located in the Darby Plains (Madison and Union Counties), Sandusky Plains (Wyandot, Crawford, and Marion Counties), northwest Ohio (e.g. Erie, Huron, Lucas, Wood Counties), and portions of western Ohio Counties (e.g. Darke, Mercer, Miami, Montgomery, Van Wert etc.).	YES  Wetland should be evaluated for possible Category 3 status  Complete Quantitative Rating	NO ✓ Complete Quantitative Rating

**Table 1. Characteristic plant species.**

<b>invasive/exotic spp</b>	<b>fen species</b>	<b>bog species</b>	<b>Oak Opening species</b>	<b>wet prairie species</b>
<i>Lythrum salicaria</i>	<i>Zygadenus elegans var. glaucus</i>	<i>Calla palustris</i>	<i>Carex cryptolepis</i>	<i>Calamagrostis canadensis</i>
<i>Myriophyllum spicatum</i>	<i>Cacalia plantaginea</i>	<i>Carex atlantica var. capillacea</i>	<i>Carex lasiocarpa</i>	<i>Calamagrostis stricta</i>
<i>Najas minor</i>	<i>Carex flava</i>	<i>Carex echinata</i>	<i>Carex stricta</i>	<i>Carex atherodes</i>
<i>Phalaris arundinacea</i>	<i>Carex sterilis</i>	<i>Carex oligosperma</i>	<i>Cladium mariscoides</i>	<i>Carex buxbaumii</i>
<i>Phragmites australis</i>	<i>Carex stricta</i>	<i>Carex trisperma</i>	<i>Calamagrostis stricta</i>	<i>Carex pellita</i>
<i>Potamogeton crispus</i>	<i>Deschampsia caespitosa</i>	<i>Chamaedaphne calyculata</i>	<i>Calamagrostis canadensis</i>	<i>Carex sartwellii</i>
<i>Ranunculus ficaria</i>	<i>Eleocharis rostellata</i>	<i>Decodon verticillatus</i>	<i>Quercus palustris</i>	<i>Gentiana andrewsii</i>
<i>Rhamnus frangula</i>	<i>Eriophorum viridicarinatum</i>	<i>Eriophorum virginicum</i>		<i>Helianthus grosseserratus</i>
<i>Typha angustifolia</i>	<i>Gentianopsis spp.</i>	<i>Larix laricina</i>		<i>Liatris spicata</i>
<i>Typha xglauca</i>	<i>Lobelia kalmii</i>	<i>Nemopanthus mucronatus</i>		<i>Lysimachia quadriflora</i>
	<i>Parnassia glauca</i>	<i>Scheuchzeria palustris</i>		<i>Lythrum alatum</i>
	<i>Potentilla fruticosa</i>	<i>Sphagnum spp.</i>		<i>Pycnanthemum virginianum</i>
	<i>Rhamnus alnifolia</i>	<i>Vaccinium macrocarpon</i>		<i>Silphium terebinthinaceum</i>
	<i>Rhynchospora capillacea</i>	<i>Vaccinium corymbosum</i>		<i>Sorghastrum nutans</i>
	<i>Salix candida</i>	<i>Vaccinium oxycoccos</i>		<i>Spartina pectinata</i>
	<i>Salix myricoides</i>	<i>Woodwardia virginica</i>		<i>Solidago riddellii</i>
	<i>Salix serissima</i>	<i>Xyris difformis</i>		
	<i>Solidago ohioensis</i>			
	<i>Tofieldia glutinosa</i>			
	<i>Triglochin maritimum</i>			
	<i>Triglochin palustre</i>			

**End of Narrative Rating. Begin Quantitative Rating on next page.**

<b>Site:</b> Wetland A	<b>Rater(s):</b> A. Dietz-Oergel, K. Simon	<b>Date:</b> 05/21/2020
------------------------	--	-------------------------

6	6
max 6 pts.	subtotal

### Metric 1. Wetland Area (size).

Select one size class and assign score.

- >50 acres (>20.2ha) (6 pts)
- 25 to <50 acres (10.1 to <20.2ha) (5 pts)
- 10 to <25 acres (4 to <10.1ha) (4 pts)
- 3 to <10 acres (1.2 to <4ha) (3 pts)
- 0.3 to <3 acres (0.12 to <1.2ha) (2pts)
- 0.1 to <0.3 acres (0.04 to <0.12ha) (1 pt)
- <0.1 acres (0.04ha) (0 pts)

5	11
max 14 pts.	subtotal

### Metric 2. Upland buffers and surrounding land use.

2a. Calculate average buffer width. Select only one and assign score. Do not double check.

- WIDE. Buffers average 50m (164ft) or more around wetland perimeter (7)
- MEDIUM. Buffers average 25m to <50m (82 to <164ft) around wetland perimeter (4)
- NARROW. Buffers average 10m to <25m (32ft to <82ft) around wetland perimeter (1)
- VERY NARROW. Buffers average <10m (<32ft) around wetland perimeter (0)

2b. Intensity of surrounding land use. Select one or double check and average.

- VERY LOW. 2nd growth or older forest, prairie, savannah, wildlife area, etc. (7)
- LOW. Old field (>10 years), shrub land, young second growth forest. (5)
- MODERATELY HIGH. Residential, fenced pasture, park, conservation tillage, new fallow field. (3)
- HIGH. Urban, industrial, open pasture, row cropping, mining, construction. (1)

20	31
max 30 pts.	subtotal

### Metric 3. Hydrology.

3a. Sources of Water. Score all that apply.

- High pH groundwater (5)
- Other groundwater (3)
- Precipitation (1)
- Seasonal/Intermittent surface water (3)
- Perennial surface water (lake or stream) (5)

3c. Maximum water depth. Select only one and assign score.

- >0.7 (27.6in) (3)
- 0.4 to 0.7m (15.7 to 27.6in) (2)
- <0.4m (<15.7in) (1)

3e. Modifications to natural hydrologic regime. Score one or double check and average.

- None or none apparent (12)
- Recovered (7)
- Recovering (3)
- Recent or no recovery (1)

3b. Connectivity. Score all that apply.

- 100 year floodplain (1)
- Between stream/lake and other human use (1)
- Part of wetland/upland (e.g. forest), complex (1)
- Part of riparian or upland corridor (1)

3d. Duration inundation/saturation. Score one or dbl check.

- Semi- to permanently inundated/saturated (4)
- Regularly inundated/saturated (3)
- Seasonally inundated (2)
- Seasonally saturated in upper 30cm (12in) (1)

Check all disturbances observed	
<input checked="" type="checkbox"/> ditch	<input checked="" type="checkbox"/> point source (nonstormwater)
<input checked="" type="checkbox"/> tile	<input checked="" type="checkbox"/> filling/grading
<input type="checkbox"/> dike	<input checked="" type="checkbox"/> road bed/RR track
<input type="checkbox"/> weir	<input type="checkbox"/> dredging
<input checked="" type="checkbox"/> stormwater input	<input type="checkbox"/> other _____

10	41
max 20 pts.	subtotal

### Metric 4. Habitat Alteration and Development.

4a. Substrate disturbance. Score one or double check and average.

- None or none apparent (4)
- Recovered (3)
- Recovering (2)
- Recent or no recovery (1)

4b. Habitat development. Select only one and assign score.

- Excellent (7)
- Very good (6)
- Good (5)
- Moderately good (4)
- Fair (3)
- Poor to fair (2)
- Poor (1)

4c. Habitat alteration. Score one or double check and average.

- None or none apparent (9)
- Recovered (6)
- Recovering (3)
- Recent or no recovery (1)

Check all disturbances observed	
<input checked="" type="checkbox"/> mowing	<input checked="" type="checkbox"/> shrub/sapling removal
<input checked="" type="checkbox"/> grazing	<input type="checkbox"/> herbaceous/aquatic bed removal
<input checked="" type="checkbox"/> clearcutting	<input type="checkbox"/> sedimentation
<input checked="" type="checkbox"/> selective cutting	<input type="checkbox"/> dredging
<input checked="" type="checkbox"/> woody debris removal	<input checked="" type="checkbox"/> farming
<input type="checkbox"/> toxic pollutants	<input checked="" type="checkbox"/> nutrient enrichment

41
subtotal this page



<b>Site:</b> Wetland A	<b>Rater(s):</b> A. Dietz-Oergel, K. Simon	<b>Date:</b> 05/21/2020
------------------------	--	-------------------------

41
----

subtotal first page

0	41
---	----

max 10 pts.      subtotal

### Metric 5. Special Wetlands.

Check all that apply and score as indicated.

- Bog (10)
- Fen (10)
- Old growth forest (10)
- Mature forested wetland (5)
- Lake Erie coastal/tributary wetland-unrestricted hydrology (10)
- Lake Erie coastal/tributary wetland-restricted hydrology (5)
- Lake Plain Sand Prairies (Oak Openings) (10)
- Relict Wet Prairies (10)
- Known occurrence state/federal threatened or endangered species (10)
- Significant migratory songbird/water fowl habitat or usage (10)
- Category 1 Wetland. See Question 1 Qualitative Rating (-10)

8	49
---	----

max 20 pts.      subtotal

### Metric 6. Plant communities, interspersions, microtopography.

6a. Wetland Vegetation Communities.

Score all present using 0 to 3 scale.

- 0 Aquatic bed
- 1 Emergent
- 1 Shrub
- 2 Forest
- 0 Mudflats
- 0 Open water
- 0 Other \_\_\_\_\_

6b. horizontal (plan view) Interspersion.

Select only one.

- High (5)
- Moderately high(4)
- Moderate (3)
- Moderately low (2)
- Low (1)
- None (0)

6c. Coverage of invasive plants. Refer to Table 1 ORAM long form for list. Add or deduct points for coverage

- Extensive >75% cover (-5)
- Moderate 25-75% cover (-3)
- Sparse 5-25% cover (-1)
- Nearly absent <5% cover (0)
- Absent (1)

6d. Microtopography.

Score all present using 0 to 3 scale.

- 0 Vegetated hummocks/tussucks
- 1 Coarse woody debris >15cm (6in)
- 1 Standing dead >25cm (10in) dbh
- 0 Amphibian breeding pools

#### Vegetation Community Cover Scale

0	Absent or comprises <0.1ha (0.2471 acres) contiguous area
1	Present and either comprises small part of wetland's vegetation and is of moderate quality, or comprises a significant part but is of low quality
2	Present and either comprises significant part of wetland's vegetation and is of moderate quality or comprises a small part and is of high quality
3	Present and comprises significant part, or more, of wetland's vegetation and is of high quality

#### Narrative Description of Vegetation Quality

low	Low spp diversity and/or predominance of nonnative or disturbance tolerant native species
mod	Native spp are dominant component of the vegetation, although nonnative and/or disturbance tolerant native spp can also be present, and species diversity moderate to moderately high, but generally w/o presence of rare threatened or endangered spp
high	A predominance of native species, with nonnative spp and/or disturbance tolerant native spp absent or virtually absent, and high spp diversity and often, but not always, the presence of rare, threatened, or endangered spp

#### Mudflat and Open Water Class Quality

0	Absent <0.1ha (0.247 acres)
1	Low 0.1 to <1ha (0.247 to 2.47 acres)
2	Moderate 1 to <4ha (2.47 to 9.88 acres)
3	High 4ha (9.88 acres) or more

#### Microtopography Cover Scale

0	Absent
1	Present very small amounts or if more common of marginal quality
2	Present in moderate amounts, but not of highest quality or in small amounts of highest quality
3	Present in moderate or greater amounts and of highest quality

49
----

**End of Quantitative Rating. Complete Categorization Worksheets.**

## ORAM Summary Worksheet

		<b>circle answer or insert score</b>	<b>Result</b>
Narrative Rating	Question 1. Critical Habitat	YES NO ✓	If yes, Category 3.
	Question 2. Threatened or Endangered Species	YES NO ✓	If yes, Category 3.
	Question 3. High Quality Natural Wetland	YES NO ✓	If yes, Category 3.
	Question 4. Significant bird habitat	YES NO ✓	If yes, Category 3.
	Question 5. Category 1 Wetlands	YES NO ✓	If yes, Category 1.
	Question 6. Bogs	YES NO ✓	If yes, Category 3.
	Question 7. Fens	YES NO ✓	If yes, Category 3.
	Question 8a. Old Growth Forest	YES NO ✓	If yes, Category 3.
	Question 8b. Mature Forested Wetland	YES NO ✓	If yes, evaluate for Category 3; may also be 1 or 2.
	Question 9b. Lake Erie Wetlands - Restricted	YES NO ✓	If yes, evaluate for Category 3; may also be 1 or 2.
	Question 9d. Lake Erie Wetlands – Unrestricted with native plants	YES NO ✓	If yes, Category 3
	Question 9e. Lake Erie Wetlands - Unrestricted with invasive plants	YES NO ✓	If yes, evaluate for Category 3; may also be 1 or 2.
Question 10. Oak Openings	YES NO ✓	If yes, Category 3	
Question 11. Relict Wet Prairies	YES NO ✓	If yes, evaluate for Category 3; may also be 1 or 2.	
Quantitative Rating	Metric 1. Size	6	
	Metric 2. Buffers and surrounding land use	5	
	Metric 3. Hydrology	20	
	Metric 4. Habitat	10	
	Metric 5. Special Wetland Communities	0	
	Metric 6. Plant communities, interspersion, microtopography	8	
	TOTAL SCORE	49	2

**Complete Wetland Categorization Worksheet.**

## Wetland Categorization Worksheet

Choices	Circle one		Evaluation of Categorization Result of ORAM
<p>Did you answer "Yes" to any of the following questions:</p> <p>Narrative Rating Nos. 2, 3, 4, 6, 7, 8a, 9d, 10</p>	<p>YES</p> <p>Wetland is categorized as a Category 3 wetland</p>	<p>NO</p> <p style="text-align: right;">✓</p>	<p>Is quantitative rating score <i>less</i> than the Category 2 scoring threshold (<i>excluding</i> gray zone)? If yes, reevaluate the category of the wetland using the narrative criteria in OAC Rule 3745-1-54(C) and biological and/or functional assessments to determine if the wetland has been over-categorized by the ORAM</p>
<p>Did you answer "Yes" to any of the following questions:</p> <p>Narrative Rating Nos. 1, 8b, 9b, 9e, 11</p>	<p>YES</p> <p>Wetland should be evaluated for possible Category 3 status</p>	<p>NO</p> <p style="text-align: right;">✓</p>	<p>Evaluate the wetland using the 1) narrative criteria in OAC Rule 3745-1-54(C) and 2) the quantitative rating score. If the wetland is determined to be a Category 3 wetland using either of these, it should be categorized as a Category 3 wetland. Detailed biological and/or functional assessments may also be used to determine the wetland's category.</p>
<p>Did you answer "Yes" to</p> <p>Narrative Rating No. 5</p>	<p>YES</p> <p>Wetland is categorized as a Category 1 wetland</p>	<p>NO</p> <p style="text-align: right;">✓</p>	<p>Is quantitative rating score <i>greater</i> than the Category 2 scoring threshold (<i>including</i> any gray zone)? If yes, reevaluate the category of the wetland using the narrative criteria in OAC Rule 3745-1-54(C) and biological and/or functional assessments to determine if the wetland has been under-categorized by the ORAM</p>
<p>Does the quantitative score fall within the scoring range of a Category 1, 2, or 3 wetland?</p>	<p>YES</p> <p style="text-align: right;">✓</p> <p>Wetland is assigned to the appropriate category based on the scoring range</p>	<p>NO</p>	<p>If the score of the wetland is located within the scoring range for a particular category, the wetland should be assigned to that category. In all instances however, the narrative criteria described in OAC Rule 3745-1-54(C) can be used to clarify or change a categorization based on a quantitative score.</p>
<p>Does the quantitative score fall with the "gray zone" for Category 1 or 2 or Category 2 or 3 wetlands?</p>	<p>YES</p> <p>Wetland is assigned to the higher of the two categories or assigned to a category based on detailed assessments and the narrative criteria</p>	<p>NO</p> <p style="text-align: right;">✓</p>	<p>Rater has the option of assigning the wetland to the higher of the two categories or to assign a category based on the results of a nonrapid wetland assessment method, e.g. functional assessment, biological assessment, etc, and a consideration of the narrative criteria in OAC rule 3745-1-54(C).</p>
<p>Does the wetland otherwise exhibit <i>moderate OR superior</i> hydrologic OR habitat, OR recreational functions AND the wetland was <i>not</i> categorized as a Category 2 wetland (in the case of moderate functions) or a Category 3 wetland (in the case of superior functions) by this method?</p>	<p>YES</p> <p>Wetland was undercategorized by this method. A written justification for recategorization should be provided on Background Information Form</p>	<p>NO</p> <p style="text-align: right;">✓</p> <p>Wetland is assigned to category as determined by the ORAM.</p>	<p>A wetland may be undercategorized using this method, but still exhibit one or more superior functions, e.g. a wetland's biotic communities may be degraded by human activities, but the wetland may still exhibit superior hydrologic functions because of its type, landscape position, size, local or regional significance, etc. In this circumstance, the narrative criteria in OAC Rule 3745-1-54(C)(2) and (3) are controlling, and the under-categorization should be corrected. A written justification with supporting reasons or information for this determination should be provided.</p>

### Final Category

Choose one	Category 1	Category 2	Category 3
------------	------------	------------	------------


✓


**End of Ohio Rapid Assessment Method for Wetlands.**



## Appendix D Photographic Log


> **Photographic Log**


<b>Photo # 1</b>	
Date: 05/13/2020	
Feature: Upland easement	
Description: South of Stream 1 (Apple Creek) the study area contains upland mowed easement forested areas.	

<b>Photo # 2</b>	
Date: 05/13/2020	
Feature: Agricultural Areas	
Description: The northern study area crosses active agricultural fields.	




> **Photographic Log**

<b>Photo # 3</b>	
Date: 04/30/2021	
Feature: Fallow Field/Lawn	
Description: The western study area crosses a newly fallow field/maintained lawn along the edge of a forested wetland (Wetland A).	

<b>Photo # 4</b>	
Date: 05/13/2020	
Feature: Residential Area	
Description: The northern extent of the study area abuts a residential property along Geyers Chapel Road.	




> **Photographic Log**


<b>Photo # 5</b>	
Date: 05/13/2020	
Feature: Wet -A North	
Description: Photo depicts datapoint Wet-A located in Wetland A on the northern side of Apple Creek.	

<b>Photo # 6</b>	
Date: 05/13/2020	
Feature: Wet -A South	
Description: Photo depicts datapoint Wet-A located in Wetland A on the northern side of Apple Creek.	



> **Photographic Log**


<b>Photo # 7</b>	
Date: 05/13/2020	
Feature: Wet -A East	
Description: Photo depicts datapoint Wet-A located in Wetland A on the northern side of Apple Creek.	

<b>Photo # 8</b>	
Date: 05/13/2020	
Feature: Wet -A West	
Description: Photo depicts datapoint Wet-A located in Wetland A on the northern side of Apple Creek.	




> **Photographic Log**


<b>Photo # 9</b>	
Date: 05/13/2020	
Feature: Up-A	
Description: Photo depicts datapoint Up-A	

<b>Photo # 10</b>	
Date: 04/30/2021	
Feature: Wet -A2 North	
Description: Photo depicts datapoint Wet-A2 located in Wetland A on the southern side of Apple Creek.	



> **Photographic Log**

<b>Photo # 11</b>	
Date: 04/30/2021	
Feature: Wet -A2 South	
Description: Photo depicts datapoint Wet-A2 located in Wetland A on the southern side of Apple Creek.	

<b>Photo # 12</b>	
Date: 04/30/2021	
Feature: Wet -A2 East	
Description: Photo depicts datapoint Wet-A2 located in Wetland A on the southern side of Apple Creek.	




> **Photographic Log**

<b>Photo # 13</b>	
Date: 04/30/2021	
Feature: Wet -A2 West	
Description: Photo depicts datapoint Wet-A2 located in Wetland A on the southern side of Apple Creek.	

<b>Photo # 14</b>	
Date: 04/30/2021	
Feature: Up-A2	
Description: Photo depicts datapoint Up-A2	




> **Photographic Log**


<b>Photo # 15</b>	
Date: 05/13/2020	
Feature: Stream 1 (Apple Creek) Upstream	
Description: Stream 1 (Apple Creek) drains west through the study area. Photo faces upstream portion of Stream 1 (Apple Creek).	

<b>Photo # 16</b>	
Date: 05/13/2020	
Feature: Stream 1 (Apple Creek) Downstream	
Description: Photo faces downstream portion of Stream 1 (Apple Creek).	



> **Photographic Log**


<b>Photo # 17</b>	
Date: 05/13/2020	
Feature: Stream 1 (Apple Creek) Substrate	
Description: Substrates of Stream 1 (Apple Creek) are dominated by cobble and gravel.	

<b>Photo # 18</b>	
Date: 05/13/2020	
Feature: Stream 2 Upstream	
Description: Stream 2 flows north to south through the northeastern extent of the study area and is channelized along Geyers Chapel Road. Photo faces upstream portion of Stream 2.	



> **Photographic Log**


<b>Photo # 19</b>	
Date: 05/13/2020	
Feature: Stream 2 Downstream	
Description: Photo faces downstream portion of Stream 2.	

<b>Photo # 20</b>	
Date: 05/13/2020	
Feature: Stream 2 Substrate	
Description: Substrates of Stream 2 are dominated by silt and clay/hardpan.	




> **Photographic Log**

<b>Photo # 21</b>	
Date: 03/04/2021	
Feature: Stream 3 Upstream	
Description: Photo faces upstream portion of Stream 3.	

<b>Photo # 22</b>	
Date: 03/04/2021	
Feature: Stream 3 Downstream	
Description: Photo faces downstream portion of Stream 3.	




> **Photographic Log**


<b>Photo # 23</b>	
Date: 03/04/2021	
Feature: Stream 3 Substrate	
Description: Substrates of Stream 3 are dominated by silt and leaf litter.	

<b>Photo # 24</b>	
Date: 04/30/2021	
Feature: Stream 4 Upstream	
Description: Photo faces upstream portion of Stream 4	




> **Photographic Log**


<b>Photo # 25</b>	
Date: 04/30/2021	
Feature: Stream 4 Downstream	
Description: Photo faces downstream portion of Stream 4.	

<b>Photo # 26</b>	
Date: 04/30/2021	
Feature: Stream 4 Substrate	
Description: Substrates of Stream 4 were dominated by gravel and clay/hardpan.	



> **Photographic Log**


<b>Photo # 27</b>	
Date: 11/18/2020	
Feature: Stream 5 Upstream	
Description: Stream 5 is an ephemeral stream that drains portions of Wetland A towards Stream 2 (Apple Creek). Photo shows the upstream portion of Stream 5.	

<b>Photo # 28</b>	
Date: 11/18/2020	
Feature: Stream 5 Downstream	
Description: Photo shows the downstream portion of Stream 5.	



> **Photographic Log**


<b>Photo # 29</b>	
Date: 11/18/2020	
Feature: Stream 5 Substrate	
Description: Substrates of Stream 5 are dominated by cobble and clay/hardpan.	

<b>Photo # 30</b>	
Date: 11/18/2020	
Feature: Stream 6 Upstream	
Description: Stream 6 is an ephemeral stream that is entirely captured within a ditch channel along the west side of North Hillcrest Drive. Photo depicts the upstream portion of Stream 6.	



> **Photographic Log**

<b>Photo # 31</b>	
Date: 11/18/2020	
Feature: Stream 6 Downstream	
Description: Photo depicts the downstream portion of Stream 46.	

<b>Photo # 32</b>	
Date: 11/18/2020	
Feature: Stream 6 Substrate	
Description: Substrates of Stream 6 are dominated by boulder and cobble.	

## **Appendix E Qualitive Habitat Evaluation Index (QHEI) and Headwater Habitat Evaluation Index (HHEI) Forms**



Stream & Location: STREAM 1 - P16 2788 RM: Date: 5/13/06 20

(APPLE CREEK) Scorers Full Name & Affiliation: K. SIMON - ECT

River Code: STORET #: Lat./ Long.: 40.8030 181.8996 Office verified location

1) SUBSTRATE Check ONLY Two substrate TYPE BOXES; estimate % or note every type present. Check ONE (Or 2 & average). BEST TYPES, OTHER TYPES, POOL RIFFLE, ORIGIN, QUALITY. Comments: 15, 2, 1, 0. Substrate Maximum 20: 18.

2) INSTREAM COVER Indicate presence 0 to 3: 0-Absent; 1-Very small amounts... AMOUNT. Check ONE (Or 2 & average). UNDERCUT BANKS, OVERHANGING VEGETATION, SHALLOWS, ROOTMATS, POOLS, ROOTWADS, BOULDERS, OXBOWS, AQUATIC MACROPHYTES, LOGS OR WOODY DEBRIS. Comments: 1, 2, 1, 2, 1, 1. Cover Maximum 20: 9.

3) CHANNEL MORPHOLOGY Check ONE in each category (Or 2 & average). SINUOSITY, DEVELOPMENT, CHANNELIZATION, STABILITY. Comments: 2, 5, 6, 3. Channel Maximum 20: 16.

4) BANK EROSION AND RIPARIAN ZONE Check ONE in each category for EACH BANK (Or 2 per bank & average). River right looking downstream. EROSION, RIPARIAN WIDTH, FLOOD PLAIN QUALITY. Comments: 2, 3.5, 1.5. Riparian Maximum 10: 7.

5) POOL / GLIDE AND RIFFLE / RUN QUALITY MAXIMUM DEPTH, CHANNEL WIDTH, CURRENT VELOCITY, Recreation Potential. Comments: 5. Pool / Current Maximum 12: 5.

Indicate for functional riffles; Best areas must be large enough to support a population of riffle-obligate species: Check ONE (Or 2 & average). RIFFLE DEPTH, RUN DEPTH, RIFFLE / RUN SUBSTRATE, RIFFLE / RUN EMBEDDEDNESS. Comments: 6. Riffle / Run Maximum 8: 6.

6) GRADIENT (20 ft/mi) DRAINAGE AREA (1343 mi^2). %POOL: 25, %GLIDE: 25, %RUN: 20, %RIFFLE: 30. Gradient Maximum 10: 8.

STREAM 1

Comment RE: Reach consistency/Is reach typical of stream?, Recreation/Observed - Inferred, Other/ Sampling observations, Concerns, Access directions, etc.

**AJ SAMPLED REACH**

Check ALL that apply

**METHOD**

- BOAT
- WADE
- L. LINE
- OTHER

**STAGE**

- 1st-sample pass-- 2nd
- HIGH
  - UP
  - NORMAL
  - LOW
  - DRY

**DISTANCE**

- 0.5 Km
- 0.2 Km
- 0.15 Km
- 0.12 Km
- OTHER

**CLARITY**

- 1st --sample pass-- 2nd
- < 20 cm
  - 20-<40 cm
  - 40-70 cm
  - > 70 cm/ CTB
  - SECCHI DEPTH

meters

**CANOPY**

- > 85%- OPEN
- 55%-<85%
- 30%-<55%
- 10%-<30%
- <10%- CLOSED

**CJ RECREATION**

- AREA DEPTH
- POOL:  >100ftz  >3ft

**BJ AESTHETICS**

- NUISANCE ALGAE
- INVASIVE MACROPHYTES
- EXCESS TURBIDITY
- DISCOLORATION
- FOAM / SCUM
- OIL SHEEN
- TRASH / LITTER
- NUISANCE ODOR
- SLUDGE DEPOSITS
- CSOs/SSOs/OUTFALLS

**DJ MAINTENANCE**

- PUBLIC / PRIVATE / BOTH / NA
- ACTIVE / HISTORIC / BOTH / NA
- YOUNG-SUCCESSION-OLD
- SPRAY / SNAG / REMOVED
- MODIFIED / DIPPED OUT / NA
- LEVEEED / ONE SIDED
- RELOCATED / CUTOFFS
- MOVING-BEDLOAD-STABLE
- ARMoured / SLUMPS
- ISLANDS / SCOURCED
- FLOOD CONTROL / DRAINAGE

Circle some & COMMENT

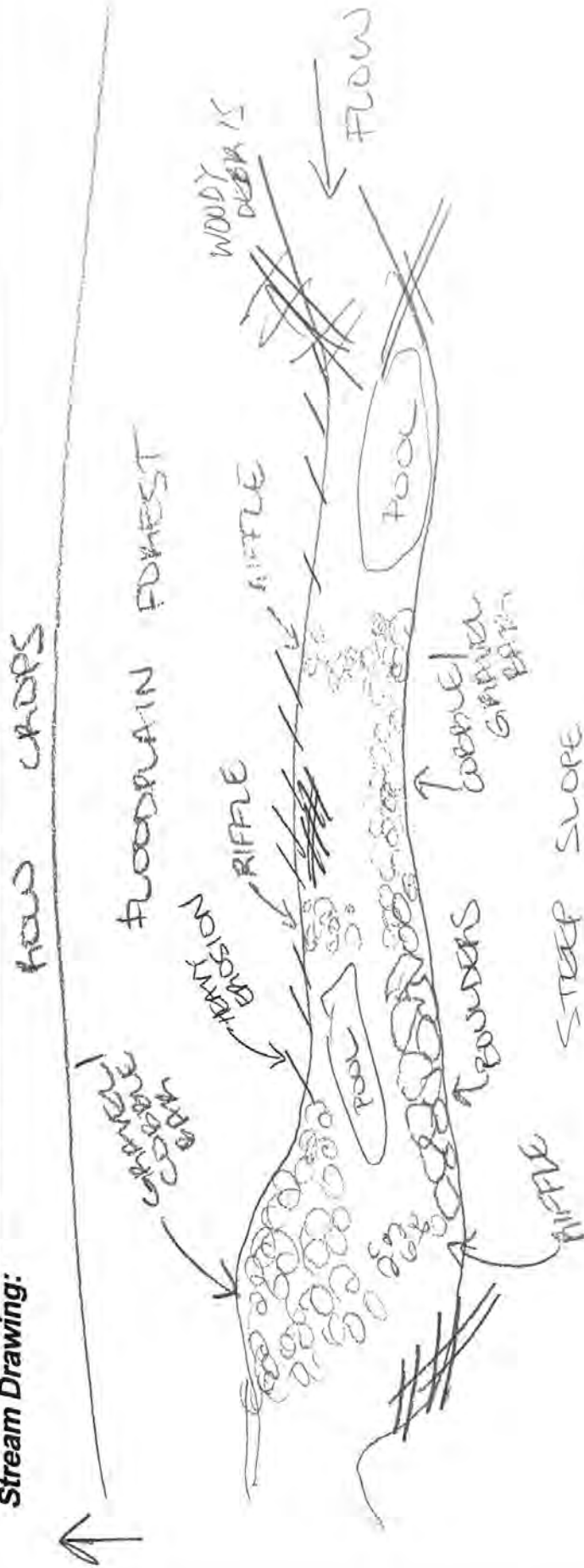
**EJ ISSUES**

- WWTP / CSO / NPDES / INDUSTRY
- HARDENED / URBAN / DIRT&GRIME
- CONTAMINATED / LANDFILL
- BMPs-CONSTRUCTION-SEDIMENT
- LOGGING / IRRIGATION / COOLING
- BANK / EROSION / SURFACE
- FALSE BANK / MANURE / LAGOON
- WASH H<sub>2</sub>O / TILE / H<sub>2</sub>O TABLE
- ACID / MINE / QUARRY / FLOW
- NATURAL / WETLAND / STAGNANT
- PARK / GOLF / LAWN / HOME
- ATMOSPHERE / DATA PAUCITY

**FJ MEASUREMENTS**

- $\bar{x}$  width
- $\bar{x}$  depth
- max. depth
- $\bar{x}$  bankfull width
- bankfull  $\bar{x}$  depth
- W/D ratio
- bankfull max. depth
- floodprone  $\bar{x}^2$  width
- entrench: ratio
- Legacy Tree:

**Stream Drawing:**





# Primary Headwater Habitat Evaluation Form

HHEI Score (sum of metrics 1, 2, 3) :

13

SITE NAME/LOCATION

STREAM 2 SITE NUMBER P1B2788 RIVER BASIN HUC 05040003 DRAINAGE AREA (mi<sup>2</sup>) 0.01

LENGTH OF STREAM REACH (ft) 200 LAT. 40.803081° LONG. -81.899995° RIVER CODE RIVER MILE

DATE 5/13/20 SCORER K. SIMON COMMENTS Modified Class I PHW

NOTE: Complete All Items On This Form - Refer to "Field Evaluation Manual for Ohio's PHWH Streams" for Instructions

STREAM CHANNEL  NONE / NATURAL CHANNEL  RECOVERED  RECOVERING  RECENT OR NO RECOVERY

MODIFICATIONS:

1. SUBSTRATE (Estimate percent of every type of substrate present. Check ONLY two predominant substrate TYPE boxes (Max of 40). Add total number of significant substrate types found (Max of 8). Final metric score is sum of boxes A & B.

TYPE	PERCENT	TYPE	PERCENT
<input type="checkbox"/> BLDR SLABS [16 pts]		<input checked="" type="checkbox"/> SILT [3 pt]	40
<input type="checkbox"/> BOULDER (>256 mm) [16 pts]		<input type="checkbox"/> LEAF PACKWOODY DEBRIS [3 pts]	
<input type="checkbox"/> BEDROCK [16 pt]		<input checked="" type="checkbox"/> FINE DETRITUS [3 pts]	5
<input type="checkbox"/> COBBLE (65-256 mm) [12 pts]		<input checked="" type="checkbox"/> CLAY or HARDPAN [0 pt]	30
<input type="checkbox"/> GRAVEL (2-64 mm) [9 pts]	10	<input type="checkbox"/> MUCK [0 pts]	
<input type="checkbox"/> SAND (<2 mm) [6 pts]	15	<input type="checkbox"/> ARTIFICIAL [3 pts]	

Total of Percentages of Bldr Slabs, Boulder, Cobble, Bedrock 0 (A) 3 (B) 5

SCORE OF TWO MOST PREDOMINATE SUBSTRATE TYPES: TOTAL NUMBER OF SUBSTRATE TYPES:

HHEI Metric Points

Substrate Max = 40

8

A + B

2. Maximum Pool Depth (Measure the maximum pool depth within the 61 meter (200 ft) evaluation reach at the time of evaluation. Avoid plunge pools from road culverts or storm water pipes) (Check ONLY one box):

<input type="checkbox"/> > 30 centimeters [20 pts]	<input type="checkbox"/> > 5 cm - 10 cm [15 pts]
<input type="checkbox"/> > 22.5 - 30 cm [30 pts]	<input type="checkbox"/> < 5 cm [5 pts]
<input type="checkbox"/> > 10 - 22.5 cm [25 pts]	<input checked="" type="checkbox"/> NO WATER OR MOIST CHANNEL [0 pts]

COMMENTS MAXIMUM POOL DEPTH (centimeters): 0

Pool Depth Max = 30

0

3. BANK FULL WIDTH (Measured as the average of 3-4 measurements) (Check ONLY one box):

<input type="checkbox"/> > 4.0 meters (> 13') [30 pts]	<input type="checkbox"/> > 1.0 m - 1.5 m (> 3' 3" - 4' 8") [15 pts]
<input type="checkbox"/> > 3.0 m - 4.0 m (> 9' 7" - 13') [25 pts]	<input checked="" type="checkbox"/> ≤ 1.0 m (≤ 3' 3") [5 pts]
<input type="checkbox"/> > 1.5 m - 3.0 m (> 4' 8" - 9' 7") [20 pts]	

COMMENTS AVERAGE BANKFULL WIDTH (meters): 1.7

Bankfull Width Max=30

5

This information must also be completed

RIPARIAN ZONE AND FLOODPLAIN QUALITY ☆NOTE: River Left (L) and Right (R) as looking downstream☆

RIPARIAN WIDTH		FLOODPLAIN QUALITY			
L	R	L	R	L	R
<input type="checkbox"/>	<input type="checkbox"/>	<input type="checkbox"/>	<input type="checkbox"/>	<input type="checkbox"/>	<input type="checkbox"/>
Wide >10m		Mature Forest, Wetland		Conservation Tillage	
<input type="checkbox"/>	<input type="checkbox"/>	<input type="checkbox"/>	<input type="checkbox"/>	<input type="checkbox"/>	<input type="checkbox"/>
Moderate 5-10m		Immature Forest, Shrub or Old Field		Urban or Industrial	
<input type="checkbox"/>	<input type="checkbox"/>	<input type="checkbox"/>	<input type="checkbox"/>	<input checked="" type="checkbox"/>	<input checked="" type="checkbox"/>
Narrow <5m		Residential, Park, New Field		Open Pasture, Row Crop	
<input checked="" type="checkbox"/>	<input checked="" type="checkbox"/>	<input type="checkbox"/>	<input type="checkbox"/>	<input type="checkbox"/>	<input type="checkbox"/>
None		Fenced Pasture		Mining or Construction	

COMMENTS

FLOW REGIME (At Time of Evaluation) (Check ONLY one box):

<input type="checkbox"/> Stream Flowing	<input type="checkbox"/> Moist Channel, isolated pools, no flow (Intermittent)
<input type="checkbox"/> Subsurface flow with isolated pools (Interstitial)	<input checked="" type="checkbox"/> Dry channel, no water (Ephemeral)

COMMENTS

SINUOSITY (Number of bends per 61 m (200 ft) of channel) (Check ONLY one box):

<input checked="" type="checkbox"/> None	<input type="checkbox"/> 1.0	<input type="checkbox"/> 2.0	<input type="checkbox"/> 3.0
<input type="checkbox"/> 0.5	<input type="checkbox"/> 1.5	<input type="checkbox"/> 2.5	<input type="checkbox"/> >3

STREAM GRADIENT ESTIMATE

Flat (0.5 ft/100 ft)  Flat to Moderate  Moderate (2 ft/100 ft)  Moderate to Severe  Severe (10 ft/100 ft)



**ADDITIONAL STREAM INFORMATION (This Information Must Also be Completed):**

QHEI PERFORMED? -  Yes  No QHEI Score \_\_\_\_\_ (If Yes, Attach Completed QHEI Form)

**DOWNSTREAM DESIGNATED USE(S)**

- WWH Name: Apple Creek Distance from Evaluated Stream: 0.06 mi
- CWH Name: \_\_\_\_\_ Distance from Evaluated Stream \_\_\_\_\_
- EWH Name: \_\_\_\_\_ Distance from Evaluated Stream \_\_\_\_\_

**MAPPING: ATTACH COPIES OF MAPS, INCLUDING THE ENTIRE WATERSHED AREA. CLEARLY MARK THE SITE LOCATION**

USGS Quadrangle Name: Wooster NRCS Soil Map Page: \_\_\_\_\_ NRCS Soil Map Stream Order \_\_\_\_\_  
 County: WAYNE Township / City: Wooster Twp.

**MISCELLANEOUS**

Base Flow Conditions? (Y/N): N Date of last precipitation: 05/11/2020 Quantity: 0.20  
 Photograph Information: \_\_\_\_\_  
 Elevated Turbidity? (Y/N): \_\_\_\_\_ Canopy (% open): 100  
 Were samples collected for water chemistry? (Y/N): N (Note lab sample no. or id. and attach results) Lab Number: \_\_\_\_\_  
 Field Measures: Temp (°C) \_\_\_\_\_ Dissolved Oxygen (mg/l) \_\_\_\_\_ pH (S.U.) \_\_\_\_\_ Conductivity (µmhos/cm) \_\_\_\_\_  
 Is the sampling reach representative of the stream (Y/N) Y If not, please explain: \_\_\_\_\_

Additional comments/description of pollution impacts: \_\_\_\_\_

**BIOTIC EVALUATION**

Performed? (Y/N): Y (If Yes, Record all observations. Voucher collections optional, NOTE: all voucher samples must be labeled with the site ID number. Include appropriate field data sheets from the Primary Headwater Habitat Assessment Manual)  
 Fish Observed? (Y/N) N Voucher? (Y/N) \_\_\_\_\_ Salamanders Observed? (Y/N) N Voucher? (Y/N) \_\_\_\_\_  
 Frogs or Tadpoles Observed? (Y/N) N Voucher? (Y/N) \_\_\_\_\_ Aquatic Macroinvertebrates Observed? (Y/N) N Voucher? (Y/N) \_\_\_\_\_  
 Comments Regarding Biology: \_\_\_\_\_

**DRAWING AND NARRATIVE DESCRIPTION OF STREAM REACH (This must be completed):**

Include important landmarks and other features of interest for site evaluation and a narrative description of the stream's location



ROW CROPS



# Primary Headwater Habitat Evaluation Form

HHEI Score (sum of metrics 1, 2, 3) :

SITE NAME/LOCATION \_\_\_\_\_  
 \_\_\_\_\_ SITE NUMBER \_\_\_\_\_ RIVER BASIN \_\_\_\_\_ DRAINAGE AREA (mi<sup>2</sup>) \_\_\_\_\_  
 LENGTH OF STREAM REACH (ft) \_\_\_\_\_ LAT. \_\_\_\_\_ LONG. \_\_\_\_\_ RIVER CODE \_\_\_\_\_ RIVER MILE \_\_\_\_\_  
 DATE \_\_\_\_\_ SCORER \_\_\_\_\_ COMMENTS \_\_\_\_\_

**NOTE: Complete All Items On This Form - Refer to "Field Evaluation Manual for Ohio's PWH Streams" for Instructions**

**STREAM CHANNEL MODIFICATIONS:**

NONE / NATURAL CHANNEL  RECOVERED  RECOVERING  RECENT OR NO RECOVERY

**1. SUBSTRATE (Estimate percent of every type of substrate present. Check ONLY two predominant substrate TYPE boxes (Max of 32). Add total number of significant substrate types found (Max of 8). Final metric score is sum of boxes A & B.**

TYPE	PERCENT	TYPE	PERCENT
<input type="checkbox"/> <input type="checkbox"/> BLDR SLABS [16 pts]	_____	<input type="checkbox"/> <input type="checkbox"/> SILT [3 pt]	_____
<input type="checkbox"/> <input type="checkbox"/> BOULDER (>256 mm) [16 pts]	_____	<input type="checkbox"/> <input type="checkbox"/> LEAF PACK/WOODY DEBRIS [3 pts]	_____
<input type="checkbox"/> <input type="checkbox"/> BEDROCK [16 pt]	_____	<input type="checkbox"/> <input type="checkbox"/> FINE DETRITUS [3 pts]	_____
<input type="checkbox"/> <input type="checkbox"/> COBBLE (65-256 mm) [12 pts]	_____	<input type="checkbox"/> <input type="checkbox"/> CLAY or HARDPAN [0 pt]	_____
<input type="checkbox"/> <input type="checkbox"/> GRAVEL (2-64 mm) [9 pts]	_____	<input type="checkbox"/> <input type="checkbox"/> MUCK [0 pts]	_____
<input type="checkbox"/> <input type="checkbox"/> SAND (<2 mm) [6 pts]	_____	<input type="checkbox"/> <input type="checkbox"/> ARTIFICIAL [3 pts]	_____

Total of Percentages of Bldr Slabs, Boulder, Cobble, Bedrock \_\_\_\_\_

(A)

Substrate Percentage Check

(B)

SCORE OF TWO MOST PREDOMINATE SUBSTRATE TYPES:

TOTAL NUMBER OF SUBSTRATE TYPES:

**HHEI Metric Points**

Substrate Max = 40

A + B

**2. Maximum Pool Depth (Measure the maximum pool depth within the 61 meter (200 ft) evaluation reach at the time of evaluation. Avoid plunge pools from road culverts or storm water pipes) (Check ONLY one box):**

<input type="checkbox"/> > 30 centimeters [20 pts]	<input type="checkbox"/> > 5 cm - 10 cm [15 pts]
<input type="checkbox"/> > 22.5 - 30 cm [30 pts]	<input type="checkbox"/> < 5 cm [5 pts]
<input type="checkbox"/> > 10 - 22.5 cm [25 pts]	<input type="checkbox"/> NO WATER OR MOIST CHANNEL [0 pts]

COMMENTS \_\_\_\_\_

MAXIMUM POOL DEPTH (centimeters):

Pool Depth Max = 30

**3. BANK FULL WIDTH (Measured as the average of 3-4 measurements) (Check ONLY one box):**

<input type="checkbox"/> > 4.0 meters (> 13') [30 pts]	<input type="checkbox"/> > 1.0 m - 1.5 m (> 3' 3" - 4' 8") [15 pts]
<input type="checkbox"/> > 3.0 m - 4.0 m (> 9' 7" - 13') [25 pts]	<input type="checkbox"/> ≤ 1.0 m (≤ 3' 3") [5 pts]
<input type="checkbox"/> > 1.5 m - 3.0 m (> 9' 7" - 4' 8") [20 pts]	

COMMENTS \_\_\_\_\_

AVERAGE BANKFULL WIDTH (meters):

Bankfull Width Max=30

**This information must also be completed**

**RIPARIAN ZONE AND FLOODPLAIN QUALITY**

☆NOTE: River Left (L) and Right (R) as looking downstream ☆

RIPARIAN WIDTH

FLOODPLAIN QUALITY

L R (Per Bank)

- Wide >10m  
  Moderate 5-10m  
  Narrow <5m  
  None

COMMENTS \_\_\_\_\_

L R (Most Predominant per Bank)

- Mature Forest, Wetland  
  Immature Forest, Shrub or Old Field  
  Residential, Park, New Field  
  Fenced Pasture

L R

- Conservation Tillage  
  Urban or Industrial  
  Open Pasture, Row Crop  
  Mining or Construction

**FLOW REGIME (At Time of Evaluation) (Check ONLY one box):**

- Stream Flowing  Moist Channel, isolated pools, no flow (Intermittent)  
 Subsurface flow with isolated pools (Interstitial)  Dry channel, no water (Ephemeral)

COMMENTS \_\_\_\_\_

**SINUOSITY (Number of bends per 61 m (200 ft) of channel) (Check ONLY one box):**

- None  1.0  2.0  3.0  
 0.5  1.5  2.5  >3

**STREAM GRADIENT ESTIMATE**

- Flat (0.5 ft/100 ft)  Flat to Moderate  Moderate (2 ft/100 ft)  Moderate to Severe  Severe (10 ft/100 ft)

**ADDITIONAL STREAM INFORMATION (This Information Must Also be Completed):**

**QHEI PERFORMED?** -  Yes  No QHEI Score \_\_\_\_\_ (If Yes, Attach Completed QHEI Form)

**DOWNSTREAM DESIGNATED USE(S)**

- WWH Name: \_\_\_\_\_ Distance from Evaluated Stream \_\_\_\_\_
- CWH Name: \_\_\_\_\_ Distance from Evaluated Stream \_\_\_\_\_
- EWH Name: \_\_\_\_\_ Distance from Evaluated Stream \_\_\_\_\_

**MAPPING: ATTACH COPIES OF MAPS, INCLUDING THE ENTIRE WATERSHED AREA. CLEARLY MARK THE SITE LOCATION**

USGS Quadrangle Name: \_\_\_\_\_ NRCS Soil Map Page: \_\_\_\_\_ NRCS Soil Map Stream Order \_\_\_\_\_  
County: \_\_\_\_\_ Township / City: \_\_\_\_\_

**MISCELLANEOUS**

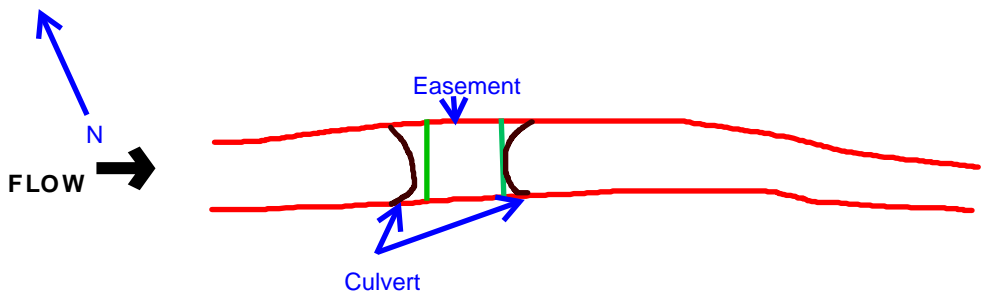
Base Flow Conditions? (Y/N): \_\_\_\_\_ Date of last precipitation: \_\_\_\_\_ Quantity: \_\_\_\_\_  
Photograph Information: \_\_\_\_\_  
Elevated Turbidity? (Y/N): \_\_\_\_\_ Canopy (% open): \_\_\_\_\_  
Were samples collected for water chemistry? (Y/N): \_\_\_\_\_ (Note lab sample no. or id. and attach results) Lab Number: \_\_\_\_\_  
Field Measures: Temp (°C) \_\_\_\_\_ Dissolved Oxygen (mg/l) \_\_\_\_\_ pH (S.U.) \_\_\_\_\_ Conductivity (µmhos/cm) \_\_\_\_\_  
Is the sampling reach representative of the stream (Y/N) \_\_\_\_\_ If not, please explain: \_\_\_\_\_  
\_\_\_\_\_  
Additional comments/description of pollution impacts: \_\_\_\_\_  
\_\_\_\_\_

**BIOTIC EVALUATION**

Performed? (Y/N): \_\_\_\_\_ (If Yes, Record all observations. Voucher collections optional. NOTE: all voucher samples must be labeled with the site ID number. Include appropriate field data sheets from the Primary Headwater Habitat Assessment Manual)  
Fish Observed? (Y/N) \_\_\_\_\_ Voucher? (Y/N) \_\_\_\_\_ Salamanders Observed? (Y/N) \_\_\_\_\_ Voucher? (Y/N) \_\_\_\_\_  
Frogs or Tadpoles Observed? (Y/N) \_\_\_\_\_ Voucher? (Y/N) \_\_\_\_\_ Aquatic Macroinvertebrates Observed? (Y/N) \_\_\_\_\_ Voucher? (Y/N) \_\_\_\_\_  
Comments Regarding Biology: \_\_\_\_\_  
\_\_\_\_\_  
\_\_\_\_\_

**DRAWING AND NARRATIVE DESCRIPTION OF STREAM REACH (This must be completed):**

Include important landmarks and other features of interest for site evaluation and a narrative description of the stream's location







# Primary Headwater Habitat Evaluation Form

**59**

**HHEI Score (sum of metrics 1, 2, 3) :**

SITE NAME/LOCATION **Stream 4**

SITE NUMBER **PIR 2788** RIVER BASIN **HUC 05040003** DRAINAGE AREA (mi<sup>2</sup>) **0.09**

LENGTH OF STREAM REACH (ft) **60** LAT. **40.80282** LONG. **-81.90373** RIVER CODE  RIVER MILE

DATE **04/30/21** SCORER **A. Dietz-O** COMMENTS **Modified Class II PHW**

**NOTE: Complete All Items On This Form - Refer to "Field Evaluation Manual for Ohio's PHWH Streams" for Instructions**

**STREAM CHANNEL MODIFICATIONS:**  NONE / NATURAL CHANNEL  RECOVERED  RECOVERING  RECENT OR NO RECOVERY

**1. SUBSTRATE (Estimate percent of every type of substrate present. Check ONLY two predominant substrate TYPE boxes (Max of 32). Add total number of significant substrate types found (Max of 8). Final metric score is sum of boxes A & B.**

TYPE	PERCENT	TYPE	PERCENT
<input type="checkbox"/> <input type="checkbox"/> BLDR SLABS [16 pts]	<input type="text" value="0%"/>	<input type="checkbox"/> <input type="checkbox"/> SILT [3 pt]	<input type="text" value="10%"/>
<input type="checkbox"/> <input type="checkbox"/> BOULDER (>256 mm) [16 pts]	<input type="text" value="0%"/>	<input type="checkbox"/> <input type="checkbox"/> LEAF PACK/WOODY DEBRIS [3 pts]	<input type="text" value="0%"/>
<input type="checkbox"/> <input type="checkbox"/> BEDROCK [16 pt]	<input type="text" value="0%"/>	<input type="checkbox"/> <input type="checkbox"/> FINE DETRITUS [3 pts]	<input type="text" value="0%"/>
<input type="checkbox"/> <input type="checkbox"/> COBBLE (65-256 mm) [12 pts]	<input type="text" value="5%"/>	<input type="checkbox"/> <input checked="" type="checkbox"/> CLAY or HARDPAN [0 pt]	<input type="text" value="30%"/>
<input checked="" type="checkbox"/> <input type="checkbox"/> GRAVEL (2-64 mm) [9 pts]	<input type="text" value="40%"/>	<input type="checkbox"/> <input type="checkbox"/> MUCK [0 pts]	<input type="text" value="0%"/>
<input type="checkbox"/> <input type="checkbox"/> SAND (<2 mm) [6 pts]	<input type="text" value="15%"/>	<input type="checkbox"/> <input type="checkbox"/> ARTIFICIAL [3 pts]	<input type="text" value="0%"/>

Total of Percentages of Bldr Slabs, Boulder, Cobble, Bedrock **5.00%** (A)

Substrate Percentage Check **100%** (B)

SCORE OF TWO MOST PREDOMINATE SUBSTRATE TYPES: **9**

TOTAL NUMBER OF SUBSTRATE TYPES: **5**

**HHEI Metric Points**

Substrate Max = 40

**14**

A + B

Pool Depth Max = 30

**2. Maximum Pool Depth (Measure the maximum pool depth within the 61 meter (200 ft) evaluation reach at the time of evaluation. Avoid plunge pools from road culverts or storm water pipes) (Check ONLY one box):**

<input type="checkbox"/> > 30 centimeters [20 pts]	<input type="checkbox"/> > 5 cm - 10 cm [15 pts]
<input type="checkbox"/> > 22.5 - 30 cm [30 pts]	<input type="checkbox"/> < 5 cm [5 pts]
<input checked="" type="checkbox"/> > 10 - 22.5 cm [25 pts]	<input type="checkbox"/> NO WATER OR MOIST CHANNEL [0 pts]

COMMENTS  MAXIMUM POOL DEPTH (centimeters): **15**

**25**

**3. BANK FULL WIDTH (Measured as the average of 3-4 measurements) (Check ONLY one box):**

<input type="checkbox"/> > 4.0 meters (> 13') [30 pts]	<input type="checkbox"/> > 1.0 m - 1.5 m (> 3' 3" - 4' 8") [15 pts]
<input type="checkbox"/> > 3.0 m - 4.0 m (> 9' 7" - 13') [25 pts]	<input type="checkbox"/> ≤ 1.0 m (≤ 3' 3") [5 pts]
<input checked="" type="checkbox"/> > 1.5 m - 3.0 m (> 9' 7" - 4' 8") [20 pts]	

COMMENTS  AVERAGE BANKFULL WIDTH (meters): **2.70**

Bankfull Width Max=30

**20**

**This information must also be completed**

**RIPARIAN ZONE AND FLOODPLAIN QUALITY** ☆NOTE: River Left (L) and Right (R) as looking downstream ☆

RIPARIAN WIDTH		FLOODPLAIN QUALITY			
L	R	L	R		
<input type="checkbox"/>	<input type="checkbox"/> (Per Bank) Wide >10m	<input type="checkbox"/>	<input type="checkbox"/> (Most Predominant per Bank) Mature Forest, Wetland	<input type="checkbox"/>	<input type="checkbox"/> Conservation Tillage
<input type="checkbox"/>	<input type="checkbox"/> Moderate 5-10m	<input type="checkbox"/>	<input type="checkbox"/> Immature Forest, Shrub or Old Field	<input type="checkbox"/>	<input type="checkbox"/> Urban or Industrial
<input type="checkbox"/>	<input type="checkbox"/> Narrow <5m	<input checked="" type="checkbox"/>	<input checked="" type="checkbox"/> Residential, Park, New Field	<input type="checkbox"/>	<input type="checkbox"/> Open Pasture, Row Crop
<input checked="" type="checkbox"/>	<input checked="" type="checkbox"/> None	<input type="checkbox"/>	<input type="checkbox"/> Fenced Pasture	<input type="checkbox"/>	<input type="checkbox"/> Mining or Construction

COMMENTS

**FLOW REGIME (At Time of Evaluation) (Check ONLY one box):**

<input type="checkbox"/> Stream Flowing	<input checked="" type="checkbox"/> Moist Channel, isolated pools, no flow (Intermittent)
<input type="checkbox"/> Subsurface flow with isolated pools (Interstitial)	<input type="checkbox"/> Dry channel, no water (Ephemeral)

COMMENTS **Significant amount of recent rain**

**SINUOSITY (Number of bends per 61 m (200 ft) of channel) (Check ONLY one box):**

<input checked="" type="checkbox"/> None	<input type="checkbox"/> 1.0	<input type="checkbox"/> 2.0	<input type="checkbox"/> 3.0
<input type="checkbox"/> 0.5	<input type="checkbox"/> 1.5	<input type="checkbox"/> 2.5	<input type="checkbox"/> >3

**STREAM GRADIENT ESTIMATE**

Flat (0.5 ft/100 ft)  Flat to Moderate  Moderate (2 ft/100 ft)  Moderate to Severe  Severe (10 ft/100 ft)

**ADDITIONAL STREAM INFORMATION (This Information Must Also be Completed):**

QHEI PERFORMED? -  Yes  No QHEI Score  (If Yes, Attach Completed QHEI Form)

**DOWNSTREAM DESIGNATED USE(S)**

<input checked="" type="checkbox"/> WWH Name: <b>Apple Creek</b>	Distance from Evaluated Stream	<b>0.05</b>
<input type="checkbox"/> CWH Name: <input type="text"/>	Distance from Evaluated Stream	<input type="text"/>
<input type="checkbox"/> EWH Name: <input type="text"/>	Distance from Evaluated Stream	<input type="text"/>

**MAPPING: ATTACH COPIES OF MAPS, INCLUDING THE ENTIRE WATERSHED AREA. CLEARLY MARK THE SITE LOCATION**

USGS Quadrangle Name: **Wooster** NRCS Soil Map Page:  NRCS Soil Map Stream Order   
 County: **Wayne** Township / City: **Wooster Twp.**

**MISCELLANEOUS**

Base Flow Conditions? (Y/N):  **Y** Date of last precipitation: **04/21/21** Quantity: **0.21**  
 Photograph Information:   
 Elevated Turbidity? (Y/N):  **N** Canopy (% open): **100%**  
 Were samples collected for water chemistry? (Y/N):  **N** (Note lab sample no. or id. and attach results) Lab Number:   
 Field Measures: Temp (°C)  Dissolved Oxygen (mg/l)  pH (S.U.)  Conductivity (µmhos/cm)   
 Is the sampling reach representative of the stream (Y/N)  **Y** If not, please explain:

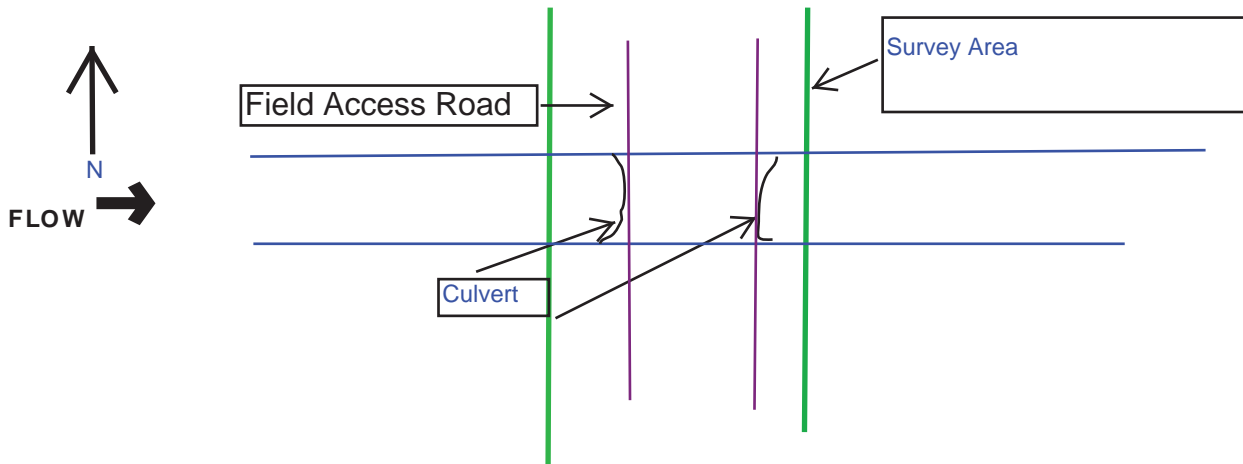
Additional comments/description of pollution impacts:

**BIOTIC EVALUATION**

Performed? (Y/N):  **N** (If Yes, Record all observations. Voucher collections optional. NOTE: all voucher samples must be labeled with the site ID number. Include appropriate field data sheets from the Primary Headwater Habitat Assessment Manual)  
 Fish Observed? (Y/N)  **N** Voucher? (Y/N)  **N** Salamanders Observed? (Y/N)  **N** Voucher? (Y/N)  **N**  
 Frogs or Tadpoles Observed? (Y/N)  **N** Voucher? (Y/N)  **N** Aquatic Macroinvertebrates Observed? (Y/N)  **N** Voucher? (Y/N)  **N**  
 Comments Regarding Biology:

**DRAWING AND NARRATIVE DESCRIPTION OF STREAM REACH (This must be completed):**

Include important landmarks and other features of interest for site evaluation and a narrative description of the stream's location





Primary Headwater Habitat Evaluation Form  
HHEI Score (sum of metrics 1, 2, 3):

30

SITE NAME / LOC. Stream 5 PIR 2788 - Apple Creek, Wooster Twp, Wayne County  
 SITE NUMBER \_\_\_\_\_ RIVER BASIN Apple Creek Drainage Area (mi<sup>2</sup>) <0.1  
 Length of Stream Reach ( 200 ft Lat. 40.802046° Long. -81.905688° RIVER MILE \_\_\_\_\_  
 DATE 11/18/2020 SCORER A. Dietz-Oergel COMMENTS Class II PHW

NOTE: Complete All Items On This Form - Refer to "Field Evaluation Manual for Ohio's PHWH Streams" for Instructions

STREAM CHANNEL  NONE / NATURAL CHANNEL  RECOVERED  RECOVERING  RECENT OR NO RECOVERY  
 MODIFICATIONS:

**1. SUBSTRATE (Estimate percent of every type of substrate present. Check ONLY two predominant substrate TYPE boxes (Max of 32). Add total number of significant substrate types found (Max of 8). Final metric score is sum of boxes A & B.)**

TYPE	PERCENT	TYPE	PERCENT
<input type="checkbox"/> <input type="checkbox"/> BLDR SLABS [16 pts]	0%	<input type="checkbox"/> <input type="checkbox"/> SILT [3 pts]	0%
<input type="checkbox"/> <input type="checkbox"/> BOULDER (>256 mm) [16 pts]	0%	<input type="checkbox"/> <input type="checkbox"/> LEAF PACK/WOODY DEBRIS [3 pts]	20%
<input type="checkbox"/> <input type="checkbox"/> BEDROCK [16 pts]	0%	<input type="checkbox"/> <input type="checkbox"/> FINE DETRITUS [3 pts]	0%
<input checked="" type="checkbox"/> <input type="checkbox"/> COBBLE (65-256 mm) [12 pts]	40%	<input checked="" type="checkbox"/> <input type="checkbox"/> CLAY or HARDPAN [0 pts]	40%
<input type="checkbox"/> <input type="checkbox"/> GRAVEL (2-64 mm) [9 pts]	0%	<input type="checkbox"/> <input type="checkbox"/> MUCK [0 pts]	0%
<input type="checkbox"/> <input type="checkbox"/> SAND (<2 mm) [6 pts]	0%	<input type="checkbox"/> <input type="checkbox"/> ARTIFICIAL [3pts]	0%

Total of Percentages of (A) \_\_\_\_\_ (B) \_\_\_\_\_  
 Bldr Slabs, Boulder, Cobble, Bedrock: 40% **12** TOTAL NUMBER OF SUBSTRATE TYPES: **3**

**SCORE OF TWO MOST PREDOMINATE SUBSTRATE TYPES: 12 TOTAL NUMBER OF SUBSTRATE TYPES: 3**

**HHEI Metric Points**  
Substrate Max = 40  
**15**  
A + B

---

**2. Maximum Pool Depth (Measure the maximum pool depth within the 61 meter (200 ft) evaluation reach at the time of evaluation. Avoid plunge pools from road culverts or storm water pipes). (Check ONLY one box):**

<input type="checkbox"/> >30 centimeters [20 pts]	<input type="checkbox"/> >5 cm - 10 cm [15 pts]
<input type="checkbox"/> >22.5 - 30 cm [30 pts]	<input type="checkbox"/> <5 cm [5 pts]
<input type="checkbox"/> >10 - 22.5 cm [25 pts]	<input checked="" type="checkbox"/> NO WATER/MOIST CHANNEL [0 pts]

COMMENTS: \_\_\_\_\_ MAXIMUM POOL DEPTH (centimeters) **0.0**

**Pool Depth Max=30**  
**0**

---

**3. BANK FULL WIDTH (Measured as the average of 3-4 measurements) (Check ONLY one box):**

<input type="checkbox"/> >4.0 meters (>13') [30 pts]	<input checked="" type="checkbox"/> >1.0 m - 1.5 m (>3'3"-4'8") [15 pts]
<input type="checkbox"/> >3.0-4.0 m (>9' 7"-13') [25 pts]	<input type="checkbox"/> ≤1.0 m (≤ 3'3") [5 pts]
<input type="checkbox"/> >1.5-3.0 m (>4' 8"-9' 7") [20 pts]	

COMMENTS: \_\_\_\_\_ AVERAGE BANKFULL WIDTH (meters) **1.2**

**Bankfull Width Max=30**  
**15**

This information must also be completed.

**RIPARIAN ZONE AND FLOODPLAIN QUALITY** \*NOTE: River Left (L) and Right (R) as looking downstream.

RIPARIAN WIDTH (Per Bank)		(FLOODPLAIN QUALITY) (Most Predominant per Bank)			
L	R	L	R	L	R
<input checked="" type="checkbox"/>	<input type="checkbox"/>	<input type="checkbox"/>	<input type="checkbox"/>	<input type="checkbox"/>	<input type="checkbox"/>
Wide > 10 m		Mature Forest, Wetland		Conservation Tillage	
<input type="checkbox"/>	<input type="checkbox"/>	<input checked="" type="checkbox"/>	<input type="checkbox"/>	<input type="checkbox"/>	<input type="checkbox"/>
Moderate 5 - 10 m		Immature Forest, Shrub or Old Field		Urban or Industrial	
<input type="checkbox"/>	<input checked="" type="checkbox"/>	<input type="checkbox"/>	<input checked="" type="checkbox"/>	<input type="checkbox"/>	<input type="checkbox"/>
Narrow < 5 m		Residential, Park, New Field		Open Pasture, Row Crop	
<input type="checkbox"/>	<input type="checkbox"/>	<input type="checkbox"/>	<input type="checkbox"/>	<input type="checkbox"/>	<input type="checkbox"/>
None		Fenced Pasture		Mining or Construction	

COMMENTS: \_\_\_\_\_

**FLOW REGIME (At Time of Evaluation) (Check ONLY one box):**

<input type="checkbox"/> Stream Flowing	<input type="checkbox"/> Moist channel, isolated pools, no flow (Intermittent)
<input type="checkbox"/> Subsurface flow with isolated pools (Interstitial)	<input checked="" type="checkbox"/> Dry channel, no water, (Ephemeral)

COMMENTS: \_\_\_\_\_

**SINUOSITY (Number of bends per 200 ft (61 m) of channel) (Check ONLY one box):**

<input type="checkbox"/> None	<input type="checkbox"/> 1.0	<input type="checkbox"/> 2.0	<input checked="" type="checkbox"/> 3.0
<input type="checkbox"/> 0.5	<input type="checkbox"/> 1.5	<input type="checkbox"/> 2.5	<input type="checkbox"/> > 3

**STREAM GRADIENT ESTIMATE**

Flat (0.5 ft/100 ft)  Flat to Moderate  Moderate (2 ft/100 ft)  Moderate to Severe  Severe (10 ft/100 ft)



**Location / Stream Name:** Stream 5 PIR 3564- N Hillcrest Dr WOF, Wooster Twp, Wayne County

**Additional Stream Information (This Information Must Also Be Completed):**

QHEI PERFORMED?  Yes  No QHEI Score \_\_\_\_\_ (If Yes, Attach Completed QHEI Form)  
DOWNSTREAM DESIGNATED USE(S): \_\_\_\_\_  
 WWH Name: Apple Creek Distance from Evaluated Stream 0.10 mi  
 CWH Name: \_\_\_\_\_ Distance from Evaluated Stream \_\_\_\_\_  
 EWH Name: \_\_\_\_\_ Distance from Evaluated Stream \_\_\_\_\_

**MAPPING: ATTACH COPIES OF MAPS, INCLUDING THE ENTIRE WATERSHED AREA. CLEARLY MARK THE SITE LOCATION.**

USGS Quad Name: Wooster NRCS Soil Map Page: \_\_\_\_\_ NRCS Soil Map Stream Order: \_\_\_\_\_  
County: Wayne Township/City: Wooster Twp.

**MISCELLANEOUS**

Base Flow Conditions? (Y/N) Y Date of Last Precipitation: 16-Nov-20 Quantity: 0.2

Photograph Information: See Attached

Elevated Turbidity? (Y/N): N Canopy (% open): 10

Were samples collected for water chemistry?(Y/N) N (Note lab sample no. or id. and attach results) Lab No.: \_\_\_\_\_

Field Measures: Temp (C) \_\_\_\_\_ Dissolved Oxygen (mg/l) \_\_\_\_\_ pH(S.U.) \_\_\_\_\_ Conductivity(µs) \_\_\_\_\_

Is the sampling reach representative of the stream (Y/N)? \_\_\_\_\_ If not, please explain: \_\_\_\_\_

Additional comments/description pollution impacts: loses channel in portion of wetland

**BIOTIC EVALUATION**

Performed? (Y/N) N (If yes, Record all observations. Voucher collections optional. NOTE: all voucher samples must be labeled with the site ID Number. Include appropriate field data sheets from the Primary Headwater Habitat Assessment Manual)

Fish Observed? (Y/N) \_\_\_\_\_ Voucher? (Y/N) \_\_\_\_\_ Salamanders Observed? (Y/N) \_\_\_\_\_ Voucher? (Y/N) \_\_\_\_\_  
Frogs/Tadpoles Observed? \_\_\_\_\_ Voucher? (Y/N) \_\_\_\_\_ Aquatic Macroinvertebrates Observed? (Y/N) \_\_\_\_\_ Voucher?(Y/N) \_\_\_\_\_

Comments Regarding Biology: \_\_\_\_\_

**DRAWING AND NARRATIVE DESCRIPTION OF STREAM REACH (This must be completed):**

Include important landmarks and other features of interest for site evaluation and a narrative description of the stream's location.

**FLOW** ➔



Primary Headwater Habitat Evaluation Form  
HHEI Score (sum of metrics 1, 2, 3):

48

SITE NAME / LOC. Stream 6 PIR 2788 - Apple Creek, Wooster Twp, Wayne County  
 SITE NUMBER \_\_\_\_\_ RIVER BASIN Apple Creek Drainage Area (mi<sup>2</sup>) <0.1  
 Length of Stream Reach ( 200 ft ) Lat. 40.802607° Long. -81.905611° RIVER MILE \_\_\_\_\_  
 DATE 11/18/2020 SCORER A. Dietz-Oergel COMMENTS Modified Class II PHW

NOTE: Complete All Items On This Form - Refer to "Field Evaluation Manual for Ohio's PHWH Streams" for Instructions

STREAM CHANNEL  NONE / NATURAL CHANNEL  RECOVERED  RECOVERING  RECENT OR NO RECOVERY  
 MODIFICATIONS:

**1. SUBSTRATE (Estimate percent of every type of substrate present. Check ONLY two predominant substrate TYPE boxes (Max of 32). Add total number of significant substrate types found (Max of 8). Final metric score is sum of boxes A & B.)**

TYPE	PERCENT	TYPE	PERCENT
<input type="checkbox"/> BLDR SLABS [16 pts]	<u>50%</u>	<input type="checkbox"/> SILT [3 pts]	<u>0%</u>
<input checked="" type="checkbox"/> BOULDER (>256 mm) [16 pts]	<u>0%</u>	<input type="checkbox"/> LEAF PACK/WOODY DEBRIS [3 pts]	<u>5%</u>
<input type="checkbox"/> BEDROCK [16 pts]	<u>0%</u>	<input type="checkbox"/> FINE DETRITUS [3 pts]	<u>0%</u>
<input checked="" type="checkbox"/> COBBLE (65-256 mm) [12 pts]	<u>20%</u>	<input type="checkbox"/> CLAY or HARDPAN [0 pts]	<u>0%</u>
<input type="checkbox"/> GRAVEL (2-64 mm) [9 pts]	<u>15%</u>	<input type="checkbox"/> MUCK [0 pts]	<u>0%</u>
<input type="checkbox"/> SAND (<2 mm) [6 pts]	<u>10%</u>	<input type="checkbox"/> ARTIFICIAL [3pts]	<u>0%</u>

Total of Percentages of (A) \_\_\_\_\_ (B) \_\_\_\_\_  
 Bldr Slabs, Boulder, Cobble, Bedrock: 70% **28** TOTAL NUMBER OF SUBSTRATE TYPES: **5**

**SCORE OF TWO MOST PREDOMINATE SUBSTRATE TYPES: 28 TOTAL NUMBER OF SUBSTRATE TYPES: 5**

**HHEI Metric Points**  
Substrate Max = 40  
**33**  
A + B

**2. Maximum Pool Depth (Measure the maximum pool depth within the 61 meter (200 ft) evaluation reach at the time of evaluation. Avoid plunge pools from road culverts or storm water pipes). (Check ONLY one box):**

<input type="checkbox"/> >30 centimeters [20 pts]	<input type="checkbox"/> >5 cm - 10 cm [15 pts]
<input type="checkbox"/> >22.5 - 30 cm [30 pts]	<input type="checkbox"/> <5 cm [5 pts]
<input type="checkbox"/> >10 - 22.5 cm [25 pts]	<input checked="" type="checkbox"/> NO WATER/MOIST CHANNEL [0 pts]

COMMENTS: \_\_\_\_\_ MAXIMUM POOL DEPTH (centimeters) 0.0

**Pool Depth Max=30**  
**0**

**3. BANK FULL WIDTH (Measured as the average of 3-4 measurements) (Check ONLY one box):**

<input type="checkbox"/> >4.0 meters (>13') [30 pts]	<input checked="" type="checkbox"/> >1.0 m - 1.5 m (>3'3"-4'8") [15 pts]
<input type="checkbox"/> >3.0-4.0 m (>9' 7"-13') [25 pts]	<input type="checkbox"/> ≤1.0 m (≤ 3'3") [5 pts]
<input type="checkbox"/> >1.5-3.0 m (>4' 8"-9' 7") [20 pts]	

COMMENTS: \_\_\_\_\_ AVERAGE BANKFULL WIDTH (meters) 1.2

**Bankfull Width Max=30**  
**15**

This information must also be completed.

**RIPARIAN ZONE AND FLOODPLAIN QUALITY** \*NOTE: River Left (L) and Right (R) as looking downstream.

RIPARIAN WIDTH (Per Bank)		(FLOODPLAIN QUALITY) (Most Predominant per Bank)			
L	R	L	R	L	R
<input type="checkbox"/>	<input type="checkbox"/>	<input type="checkbox"/>	<input type="checkbox"/>	<input type="checkbox"/>	<input type="checkbox"/>
<input type="checkbox"/>	<input type="checkbox"/>	<input type="checkbox"/>	<input type="checkbox"/>	<input type="checkbox"/>	<input type="checkbox"/>
<input type="checkbox"/>	<input type="checkbox"/>	<input checked="" type="checkbox"/>	<input type="checkbox"/>	<input type="checkbox"/>	<input type="checkbox"/>
<input checked="" type="checkbox"/>	<input checked="" type="checkbox"/>	<input type="checkbox"/>	<input type="checkbox"/>	<input type="checkbox"/>	<input type="checkbox"/>

COMMENTS: along roadway

**FLOW REGIME (At Time of Evaluation) (Check ONLY one box):**

<input type="checkbox"/> Stream Flowing	<input type="checkbox"/> Moist channel, isolated pools, no flow (Intermittent)
<input type="checkbox"/> Subsurface flow with isolated pools (Interstitial)	<input checked="" type="checkbox"/> Dry channel, no water, (Ephemeral)

COMMENTS: \_\_\_\_\_

**SINUOSITY (Number of bends per 200 ft (61 m) of channel) (Check ONLY one box):**

<input checked="" type="checkbox"/> None	<input type="checkbox"/> 1.0	<input type="checkbox"/> 2.0	<input type="checkbox"/> 3.0
<input type="checkbox"/> 0.5	<input type="checkbox"/> 1.5	<input type="checkbox"/> 2.5	<input type="checkbox"/> > 3

**STREAM GRADIENT ESTIMATE**

Flat (0.5 ft/100 ft)  Flat to Moderate  Moderate (2 ft/100 ft)  Moderate to Severe  Severe (10 ft/100 ft)

**Location / Stream Name:** Stream 4 PIR 3564- N Hillcrest Dr WOF, Wooster Twp, Wayne County

**Additional Stream Information (This Information Must Also Be Completed):**

QHEI PERFORMED?  Yes  No QHEI Score \_\_\_\_\_ (If Yes, Attach Completed QHEI Form)  
DOWNSTREAM DESIGNATED USE(S): \_\_\_\_\_  
 WWH Name: Apple Creek Distance from Evaluated Stream 0.0 mi  
 CWH Name: \_\_\_\_\_ Distance from Evaluated Stream \_\_\_\_\_  
 EWH Name: \_\_\_\_\_ Distance from Evaluated Stream \_\_\_\_\_

**MAPPING: ATTACH COPIES OF MAPS, INCLUDING THE ENTIRE WATERSHED AREA. CLEARLY MARK THE SITE LOCATION.**

USGS Quad Name: Wooster NRCS Soil Map Page: \_\_\_\_\_ NRCS Soil Map Stream Order: \_\_\_\_\_  
County: Wayne Township/City: Wooster Twp

**MISCELLANEOUS**

Base Flow Conditions? (Y/N) Y Date of Last Precipitation: 16-Nov-20 Quantity: 0.2

Photograph Information: See Attached

Elevated Turbidity? (Y/N): N Canopy (% open): 100

Were samples collected for water chemistry?(Y/N) N (Note lab sample no. or id. and attach results) Lab No.: \_\_\_\_\_

Field Measures: Temp (C) \_\_\_\_\_ Dissolved Oxygen (mg/l) \_\_\_\_\_ pH(S.U.) \_\_\_\_\_ Conductivity(µs) \_\_\_\_\_

Is the sampling reach representative of the stream (Y/N)? \_\_\_\_\_ If not, please explain: \_\_\_\_\_

Additional comments/description pollution impacts: flows into Apple Creek

**BIOTIC EVALUATION**

Performed? (Y/N) N (If yes, Record all observations. Voucher collections optional. NOTE: all voucher samples must be labeled with the site ID Number. Include appropriate field data sheets from the Primary Headwater Habitat Assessment Manual)

Fish Observed? (Y/N) \_\_\_\_\_ Voucher? (Y/N) \_\_\_\_\_ Salamanders Observed? (Y/N) \_\_\_\_\_ Voucher? (Y/N) \_\_\_\_\_  
Frogs/Tadpoles Observed? \_\_\_\_\_ Voucher? (Y/N) \_\_\_\_\_ Aquatic Macroinvertebrates Observed? (Y/N) \_\_\_\_\_ Voucher?(Y/N) \_\_\_\_\_

Comments Regarding Biology: \_\_\_\_\_

**DRAWING AND NARRATIVE DESCRIPTION OF STREAM REACH (This must be completed):**

Include important landmarks and other features of interest for site evaluation and a narrative description of the stream's location.

**FLOW** ➔

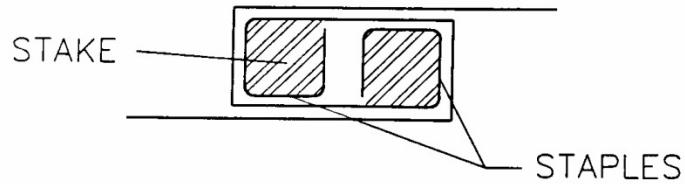


**Attachment C**

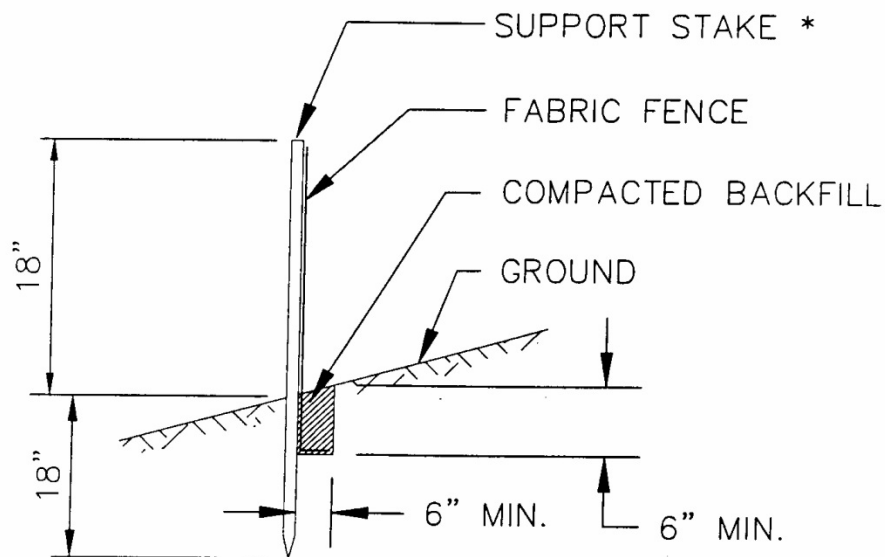
Typical Construction Drawings

## DETAIL D-1

### FILTER FABRIC FENCE DETAIL



### JOINING FENCE SECTIONS



\*Stakes spaced @ 8' maximum. Use 2"x 2" wood or equivalent steel stakes.

Filter Fabric Fence must be placed at level existing grade. Both ends of the barrier must be extended at least 8 feet up slope at 45 degrees to the main barrier alignment.

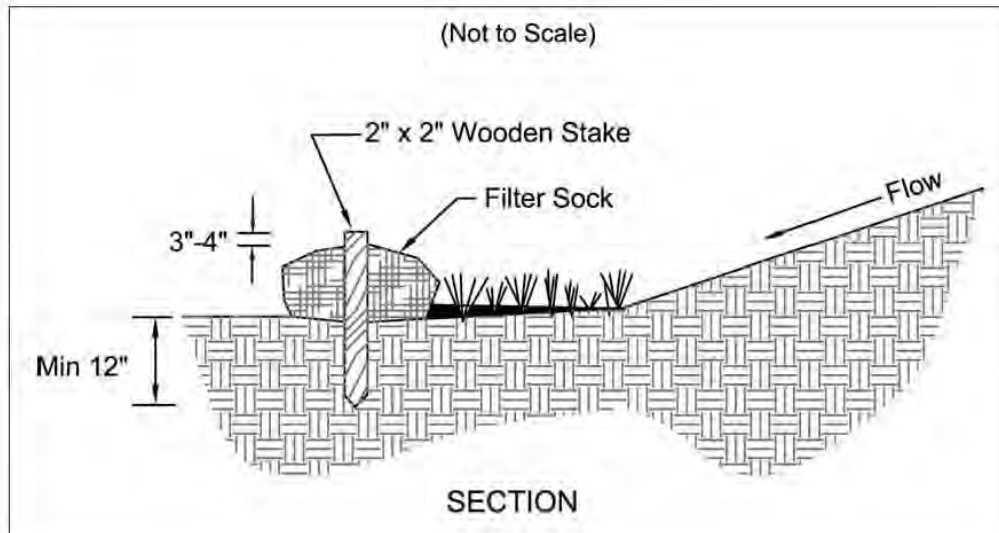
Trench shall be backfilled and compacted to prevent runoff from cutting underneath the fence.

Sediment must be removed when accumulations reach 1/2 the above ground height of the fence.

Any section of Filter fabric fence that has been undermined or topped should be immediately replaced.

## DETAIL D-2

### FILTER SOCK DETAIL



1. Materials – Compost used for filter socks shall be weed, pathogen and insect free and free of any refuse, contaminants or other materials toxic to plant growth. They shall be derived from a well-decomposed source of organic matter and consist of a particles ranging from 3/8" to 2".
2. Filter Socks shall be 3 or 5 mil continuous, tubular, HDPE 3/8" knitted mesh netting material, filled with compost passing the above specifications for compost products.

#### INSTALLATION:

3. Filter socks will be placed on a level line across slopes, generally parallel to the base of the slope or other affected area. On slopes approaching 2:1, additional socks shall be provided at the top and as needed mid-slope.
4. Filter socks intended to be left as a permanent filter or part of the natural landscape, shall be seeded at the time of installation for establishment of permanent vegetation.

5. Filter Socks are not to be used in concentrated flow situations or in runoff channels.

#### MAINTENANCE:

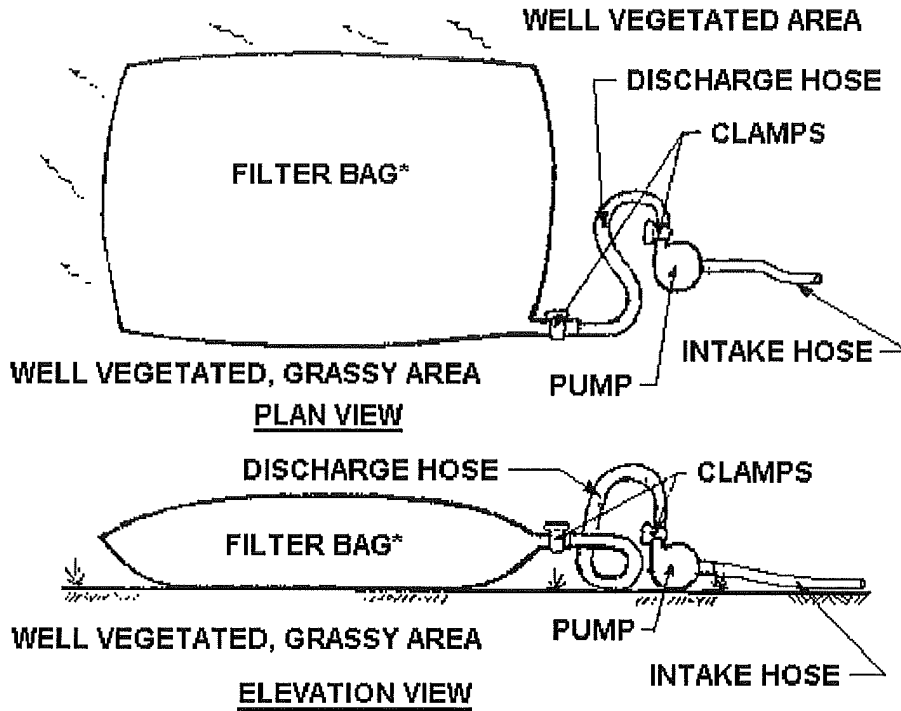
6. Routinely inspect filter socks after each significant rain, maintaining filter socks in a functional condition at all times.
7. Remove sediments collected at the base of the filter socks when they reach 1/3 of the exposed height of the practice.
8. Where the filter sock deteriorates or fails, it will be repaired or replaced with a more effective alternative.
9. Removal – Filter socks will be dispersed on site when no longer required in such a way as to facilitate and not obstruct seedings.

Note: Filter socks may not require stakes if used in areas of little to no slope, for short duration, and/or for relatively small disturbances such as sidecast piles from service line tie-ins.



# DETAIL D-3

## PUMPED WATER FILTER BAG DETAIL



Filter bags shall be made from non-woven geotextile material sewn with high strength, double stitched "J" type seams. They shall be capable of trapping particles larger than 150 microns.

A suitable means of accessing the bag with machinery required for disposal purposes must be provided. Filter bags shall be replaced when they become 1/2 full. Spare bags shall be kept available for replacement of those that have failed or are filled.

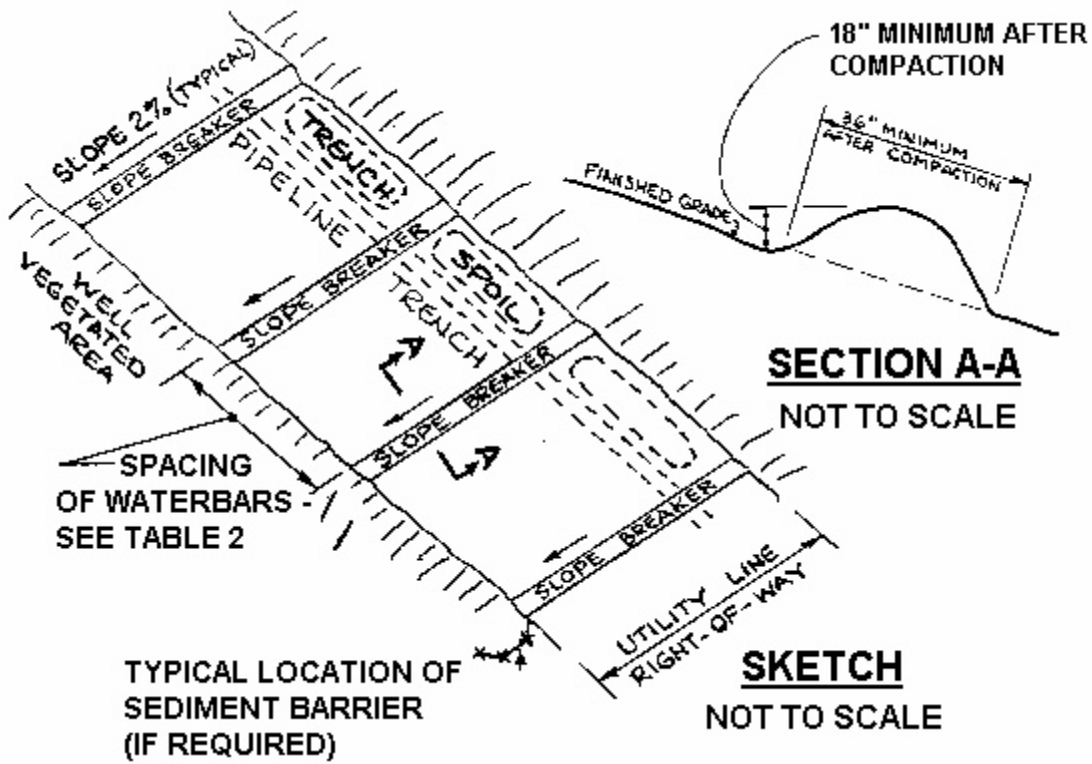
Bags shall be located in a well-vegetated (grassy) area, and discharge onto stable, erosion resistant areas. Where this is not possible, a geotextile flow path shall be provided. Bags should not be placed on slopes greater than 5%.

For hydrostatic discharge, the pumping rate is 350-500 gallons per minute (gpm). For trench dewatering, the pumping rate shall be no more than 750 gpm. Floating pump intakes should be considered to allow sediment-free water to be discharged during dewatering.

Filter bags shall be inspected daily. If any problem is detected, pumping shall cease immediately and not resume until the problem is corrected.

# DETAIL D-4

## WATERBAR INSTALLATION



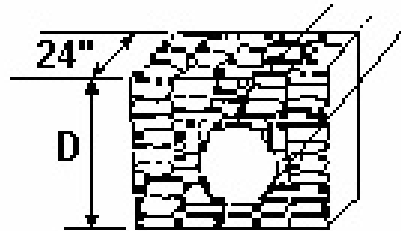
Required Spacing for Temporary and Permanent Waterbars	
Percent Slope	Spacing (FT)
1	400
2	250
5	135
10	80
15	60
20	45

Waterbars should be constructed at a slope of 1% and discharge to a well-vegetated area. Waterbars should not discharge into an open trench. Waterbars should be oriented so that the discharge does not flow back onto the ROW. Obstructions, (e.g. silt fence, rock filters, etc.) should not be placed in any waterbars. Where needed, they should be located below the discharge end of the waterbar.

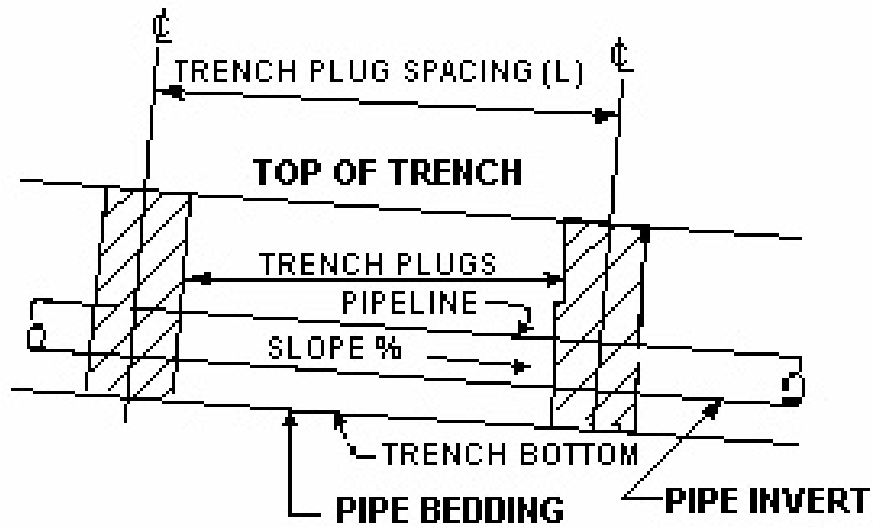
# DETAIL D-5

## TRENCH PLUG INSTALLATION DETAIL

D - DEPTH TO BOTTOM OF TRENCH



**SECTION VIEW**  
NOT TO SCALE



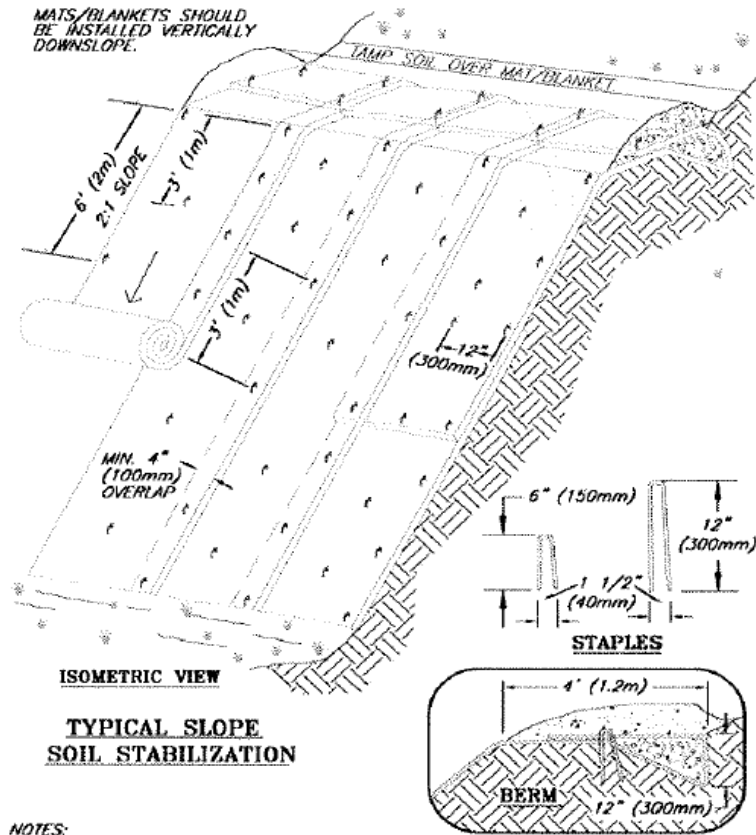
**ELEVATION**  
NOT TO SCALE



# DETAIL D-6

## EROSION CONTROL MATTING DETAIL

### EROSION CONTROL BLANKET DETAIL



**NOTES:**

1. SLOPE SURFACE SHALL BE FREE OF ROCKS, CLODS, STICKS AND GRASS. MATS/BLANKETS SHALL HAVE GOOD SOIL CONTACT.
2. APPLY PERMANENT SEEDING BEFORE PLACING BLANKETS.
3. LAY BLANKETS LOOSELY AND STAKE OR STAPLE TO MAINTAIN DIRECT CONTACT WITH THE SOIL. DO NOT STRETCH.

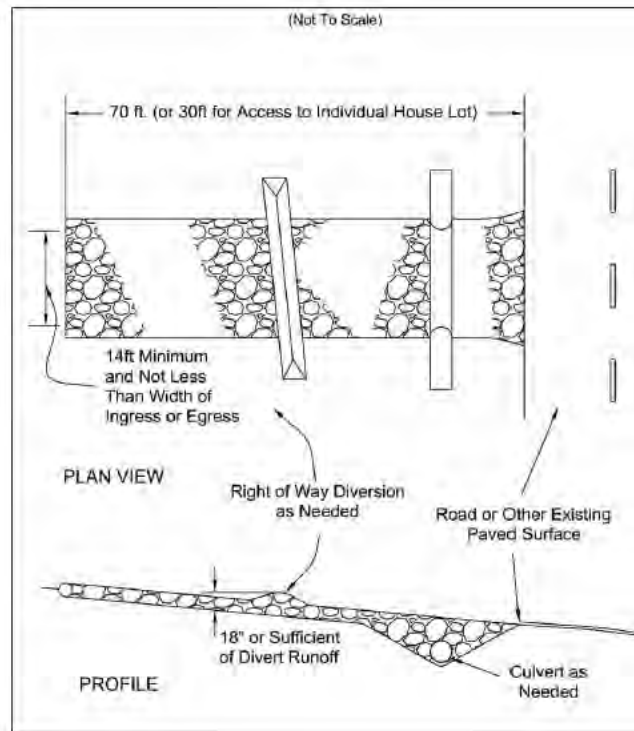
NOT TO SCALE

**EROSION BLANKETS & TURF REINFORCEMENT MATS SLOPE INSTALLATION**

Refer to manufacturer's lining installation detail for overlap, embedment, staple patterns, and vegetative stabilization specifications

# DETAIL D-7

## ROCK CONSTRUCTION ENTRANCE DETAIL



Specifications  
for

### Construction Entrance

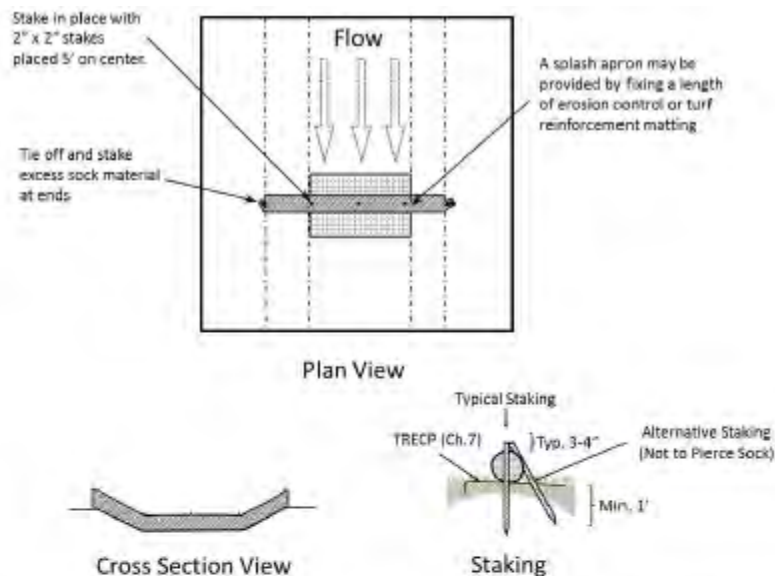
1. Stone Size—ODOT # 2 (1.5-2.5 inch) stone shall be used, or recycled concrete equivalent.
2. Length—The Construction entrance shall be as long as required to stabilize high traffic areas but not less than 70 ft. (exception: apply 30 ft. minimum to single residence lots).
3. Thickness -The stone layer shall be at least 6 inches thick for light duty entrances or at least 10 inches for heavy duty use.
4. Width -The entrance shall be at least 14 feet wide, but not less than the full width at points where ingress or egress occurs.
5. Geotextile -A geotextile shall be laid over the entire area prior to placing stone. It shall be composed of strong rot-proof polymeric fibers and meet the following specifications:
6. Timing—The construction entrance shall be installed as soon as is practicable before major grading activities.
7. Culvert -A pipe or culvert shall be constructed under the entrance if needed to prevent surface water from flowing across the entrance or to prevent runoff from being directed out onto paved surfaces.
8. Water Bar -A water bar shall be constructed as part of the construction entrance if needed to prevent surface runoff from flowing the length of the construction entrance and out onto paved surfaces.
9. Maintenance -Top dressing of additional stone shall be applied as conditions demand. Mud spilled, dropped, washed or tracked onto public roads, or any surface where runoff is not checked by sediment controls, shall be removed immediately. Removal shall be accomplished by scraping or sweeping.
10. Construction entrances shall not be relied upon to remove mud from vehicles and prevent off-site tracking. Vehicles that enter and leave the construction-site shall be restricted from muddy areas.
11. Removal—the entrance shall remain in place until the disturbed area is stabilized or replaced with a permanent roadway or entrance.

Figure 7.4.1

Geotextile Specification for Construction Entrance	
Minimum Tensile Strength	200 lbs.
Minimum Puncture Strength	80 psi.
Minimum Tear Strength	50 lbs.
Minimum Burst Strength	320 psi.
Minimum Elongation	20%
Equivalent Opening Size	EOS < 0.6 mm.
Permittivity	1×10 <sup>-3</sup> cm/sec.

## DETAIL D-8

### COMPOST SOCK CHECK DAM DETAIL

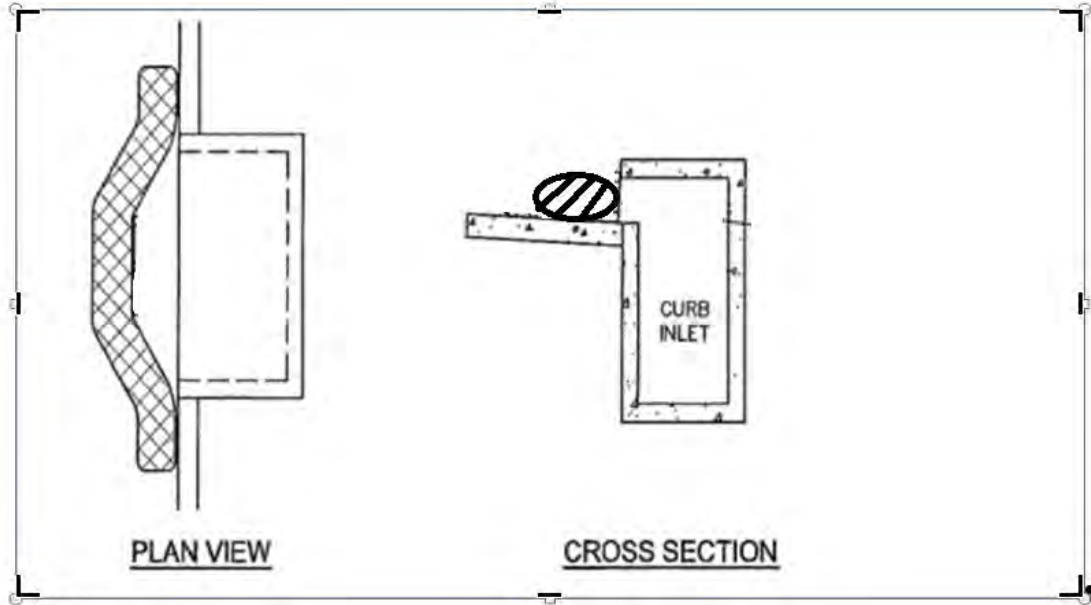


1. Compost sock netting shall use a knitted mesh fabric with 1/8-3/8 inch openings, and compost media with particle sizes 99% < 3 inches, and 60% > 3/8 inches (conforming to media described in Chapter 6 Filter Sock).
2. Compost sock check dams shall be used in areas that drain 5 acres or less.
3. Sediment shall be removed from behind the sock when it reaches 1/2 the height of the check dam.
4. Compost sock check dams shall be constructed with 12, 18, or 24 in diameter compost socks, and shall completely cover the width of the channel. The midpoint of the compost sock check dam shall be a minimum of 6 inches lower than the sides in order to direct flow across the center and away from the channel sides. Filter sock check dams shall be filled to a density such that they shall reach their intended height (diameter). After installation and use, they shall be considered unsuitable and in need of replacement after falling below 80% of their minimum required height (diameter).
5. Although no trenching is necessary, compost sock check dams shall be placed on a graded surface where consistent contact with the soil surface is made without bridging over gaps, rills, gullies, stones or other irregularities.
6. Place compost sock check dams so that the ends extend to the top of bank. Staking for compost sock check dams shall use 2 inch x 2 inch wooden stakes, placed 5 foot on center. Stake length shall allow them to be driven 12 inches into existing soil and allow at least 2 inches above the sock.
7. Space compost sock check dams so that the toe of the upstream dam is at the same elevation or lower elevation as the top of the downstream compost sock check dam (at the center of the channel). This will be influenced by the height of the sock and gradient of the waterway.
8. A splash apron may be needed where flows over the sock may erode the channel and undercut the compost sock check dam. Create the apron by fixing a length of Temporary Rolled Erosion Control Product (Erosion Control Matting) or Turf Reinforcement Matting starting upstream of the sock a distance equal to the sock height and extending a length two times the height of the compost sock check dam. See Chapter 7 for information regarding these materials. Materials used should be able to be left in place (e.g. biodegradable/photodegradable TREC) without creating problems for future mowing or maintenance of the channel.



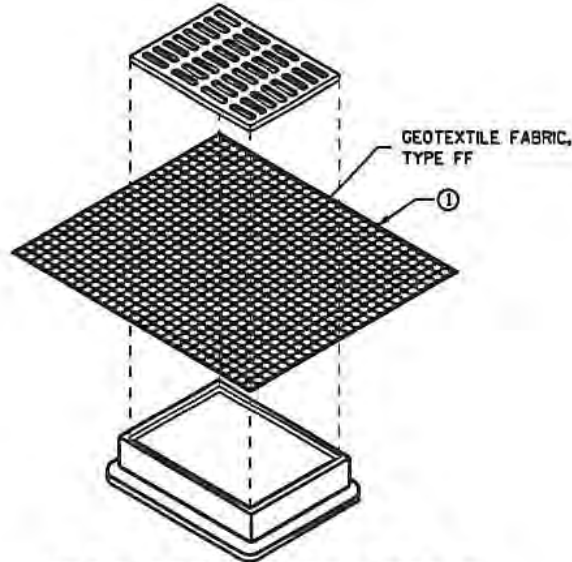
DETAIL D-9A

**CURB INLET PROTECTION**



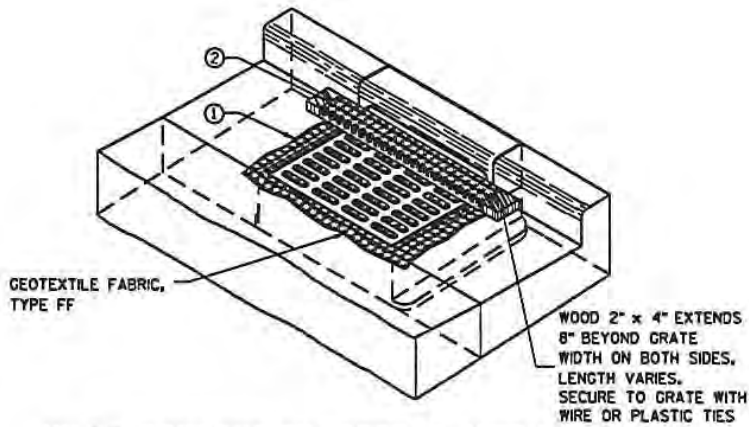
# DETAIL **D-9B**

## CURB INLET PROTECTION



### INLET PROTECTION, TYPE B (WITHOUT CURB BOX)

(CAN BE INSTALLED IN ANY INLET WITHOUT A CURB BOX)



### INLET PROTECTION, TYPE C (WITH CURB BOX)

## INSTALLATION NOTES

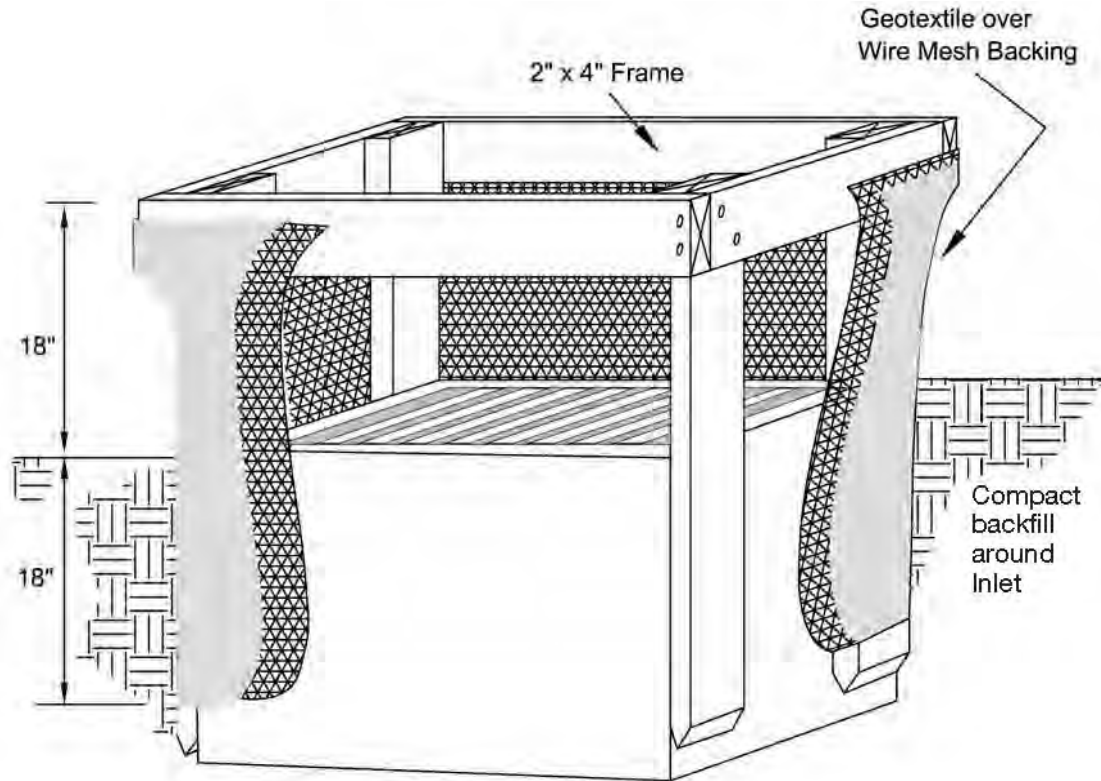
### TYPE B & C

TRIM EXCESS FABRIC IN THE FLOW LINE TO WITHIN 3" OF THE GRATE.

THE CONTRACTOR SHALL DEMONSTRATE A METHOD OF MAINTENANCE, USING A SEWN FLAP, HAND HOLDS OR OTHER METHOD TO PREVENT ACCUMULATED SEDIMENT FROM ENTERING THE INLET.

## DETAIL D-9C

### GEOTEXTILE INLET PROTECTION DETAIL



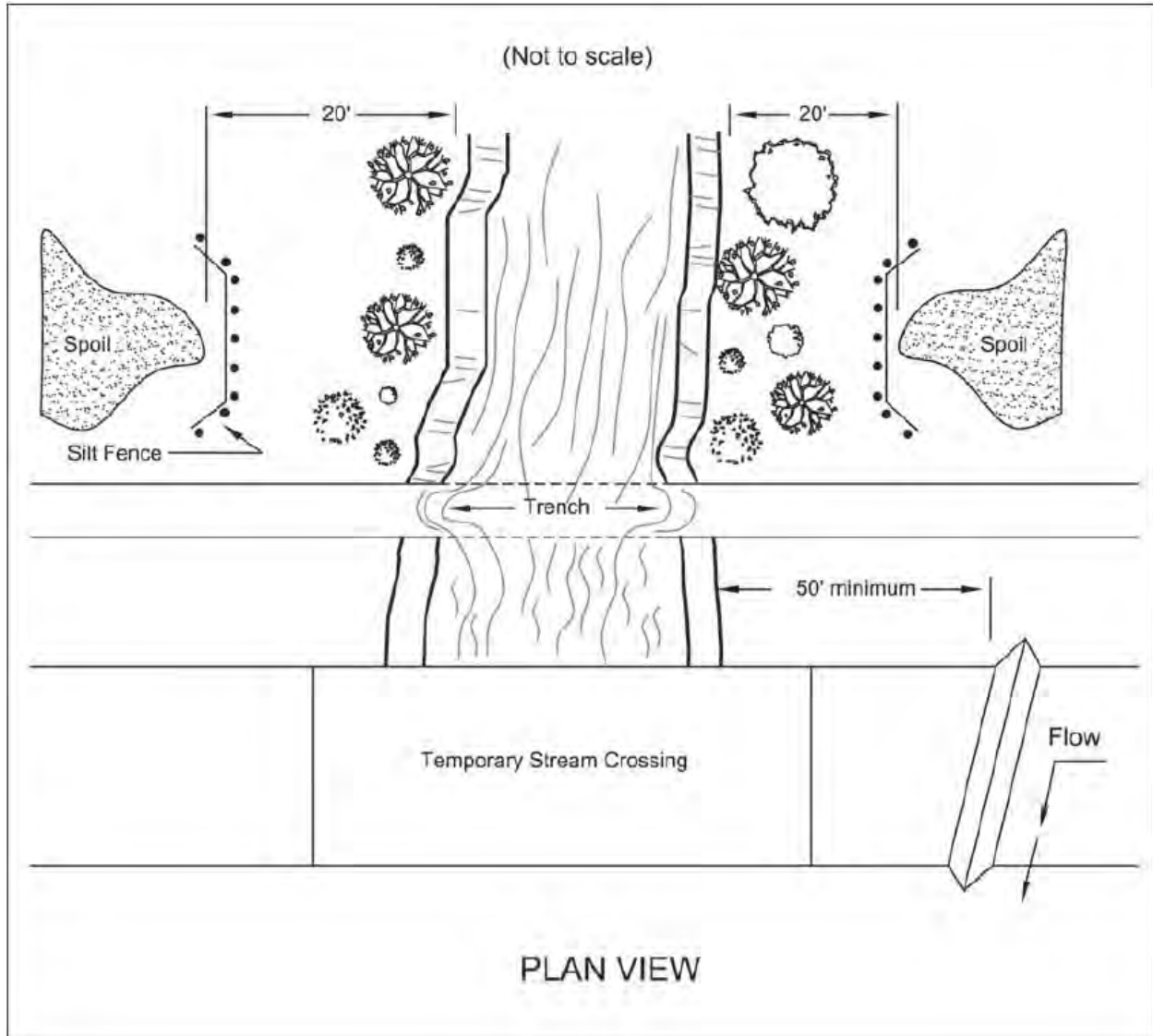
#### SECTION

1. Inlet protection shall be constructed either before upslope land disturbance begins or before the inlet becomes functional.
2. The earth around the inlet shall be excavated completely to a depth at least 18 inches.
3. The wooden frame shall be constructed of 2-inch by 4-inch construction grade lumber. The 2-inch by 4-inch posts shall be driven one (1) ft. into the ground at four corners of the inlet and the top portion of 2-inch by 4-inch frame assembled using the overlap joint shown. The top of the frame shall be at least 6 inches below adjacent roads if ponded water will pose a safety hazard to traffic.
4. Wire mesh shall be of sufficient strength to support fabric with water fully impounded against it. It shall be stretched tightly around the frame and fastened securely to the frame.
5. Geotextile material shall have an equivalent opening size of 20-40 sieve and be resistant to sunlight. It shall be stretched tightly around the frame and fastened securely. It shall extend from the top of the frame to 18 inches below the inlet notch elevation. The geotextile shall overlap across one side of the inlet so the ends of the cloth are not fastened to the same post.
6. Backfill shall be placed around the inlet in compacted 6inch layers until the earth is even with notch elevation on ends and top elevation on sides.
7. A compacted earth dike or check dam shall be constructed in the ditch line below the inlet if the inlet is not in a depression. The top of the dike shall be at least 6 inches higher than the top of the frame.
8. Filter fabric and filter socks can also be used as inlet protection.



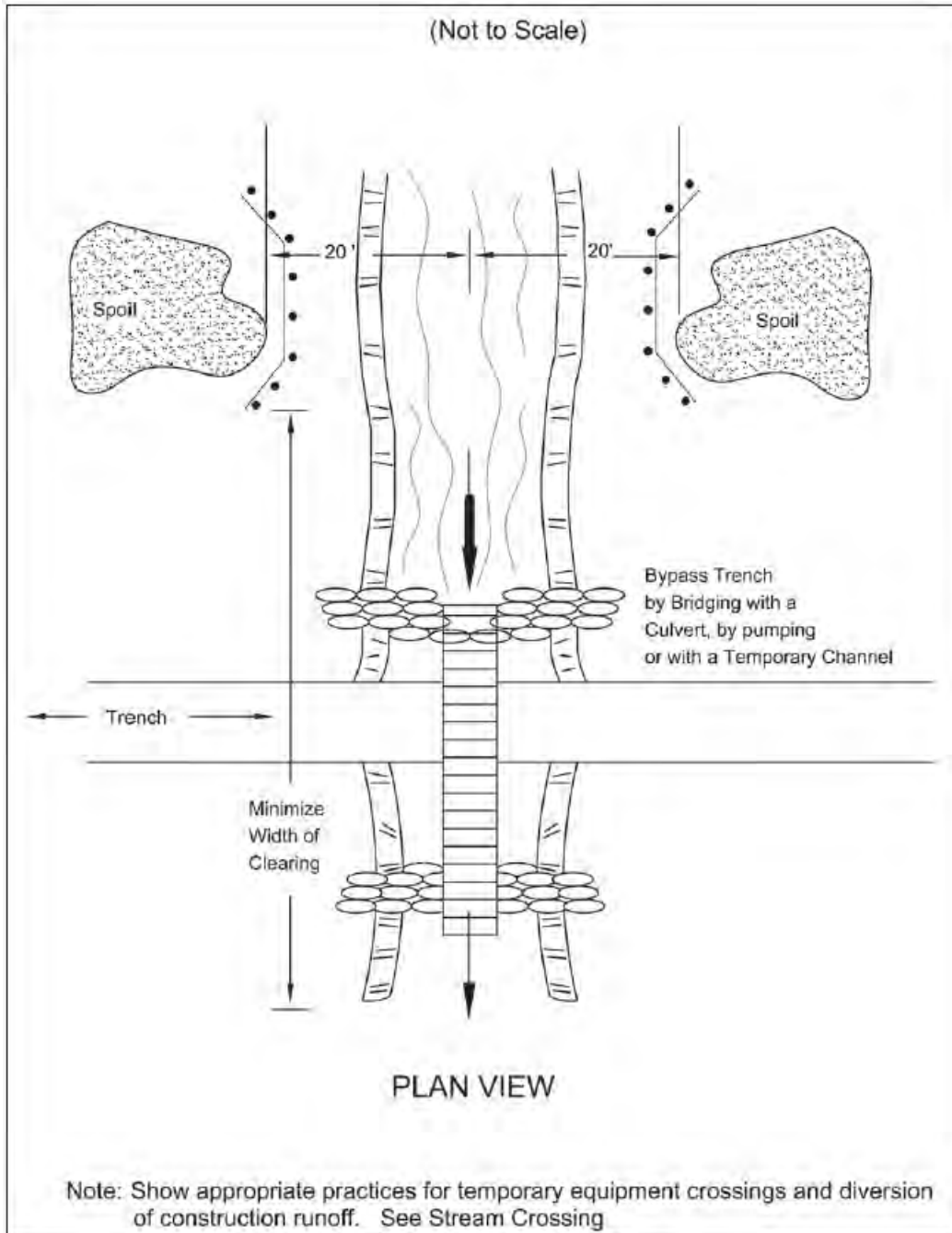
# DETAIL **D-10**

## LARGE STREAM UTILITY CROSSING



# DETAIL **D-11**

## SMALL STREAM UTILITY CROSSING

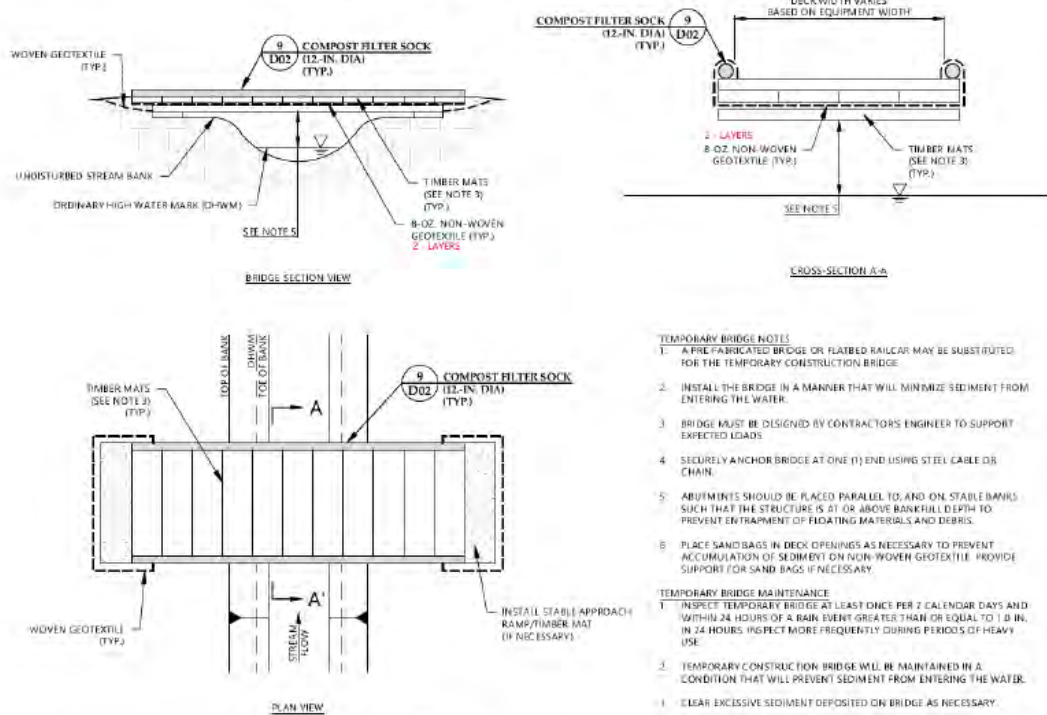


Notes: A diversion barrier may also be used to direct water away from the pipe trench  
Trench plugs will be installed as necessary on each side of water body crossings.

# DETAIL D-12

## TEMPORARY ACCESS BRIDGE

### TEMPORARY ACCESS BRIDGE



- TEMPORARY BRIDGE NOTES**
1. A PRE-FABRICATED BRIDGE OR FLATBED RAILCAR MAY BE SUBSTITUTED FOR THE TEMPORARY CONSTRUCTION BRIDGE.
  2. INSTALL THE BRIDGE IN A MANNER THAT WILL MINIMIZE SEDIMENT FROM ENTERING THE WATER.
  3. BRIDGE MUST BE DESIGNED BY CONTRACTOR'S ENGINEER TO SUPPORT EXPECTED LOADS.
  4. SECURELY ANCHOR BRIDGE AT ONE (1) END USING STEEL CABLE OR CHAIN.
  5. ABUTMENTS SHOULD BE PLACED PARALLEL TO, AND ON STABLE BANKS SUCH THAT THE STRUCTURE IS AT OR ABOVE BANKFULL DEPTH TO PREVENT ENTRAPMENT OF FLOATING MATERIALS AND DEBRIS.
  6. PLACE SAND BAGS IN DECK OPENINGS AS NECESSARY TO PREVENT ACCUMULATION OF SEDIMENT ON NON-WOVEN GEOTEXTILE. PROVIDE SUPPORT FOR SAND BAGS IF NECESSARY.
- TEMPORARY BRIDGE MAINTENANCE**
1. INSPECT TEMPORARY BRIDGE AT LEAST ONCE PER 7 CALENDAR DAYS AND WITHIN 24 HOURS OF A RAIN EVENT GREATER THAN OR EQUAL TO 1.0 IN. IN 24 HOURS. INSPECT MORE FREQUENTLY DURING PERIODS OF HEAVY USE.
  2. TEMPORARY CONSTRUCTION BRIDGE WILL BE MAINTAINED IN A CONDITION THAT WILL PREVENT SEDIMENT FROM ENTERING THE WATER.
  3. CLEAR EXCESSIVE SEDIMENT DEPOSITED ON BRIDGE AS NECESSARY.

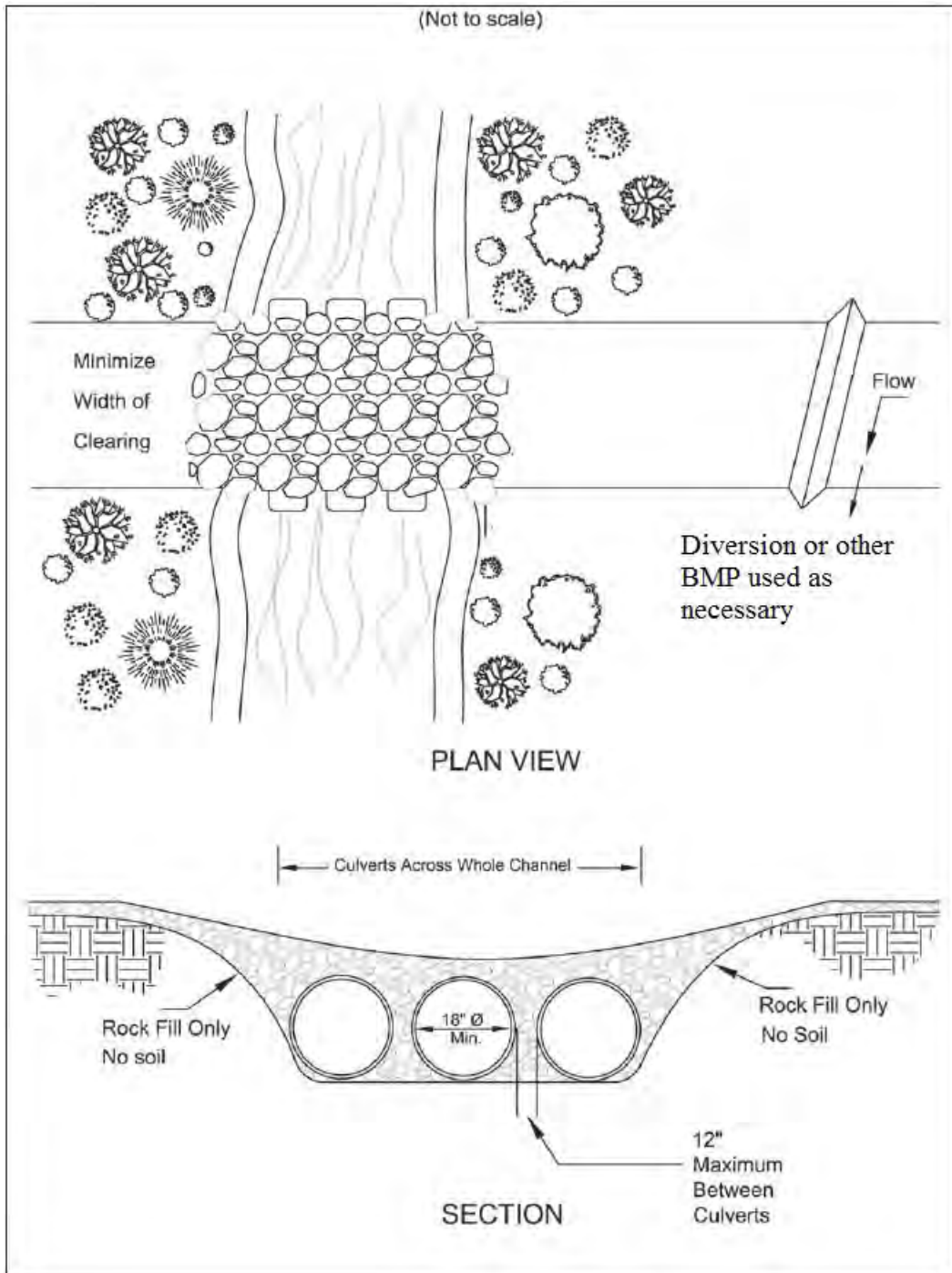
**7** TEMPORARY BRIDGE  
D02 NOT TO SCALE

- Notes:**
1. Culvert Pipes may be utilized instead of footings, piers or other bridge supports.
  2. Bridge will be temporarily removed during high water events.
  3. Bridge to remain until the completion of final restoration.
  4. Filter socks shall surround the bridge structure above the water line; removed during use, and replaced at night.
  5. Ramp approaches can be either graded or dug into the ground. Stone may be used on approaches.
  6. **Winter Conditions:** When necessary, excess ice and snow should be removed from the mats to allow the equipment to have proper traction. Ensure mats are positioned and leveled to decrease the chance equipment could slide on them. Exercise Stop Work Authority if conditions are unsafe.



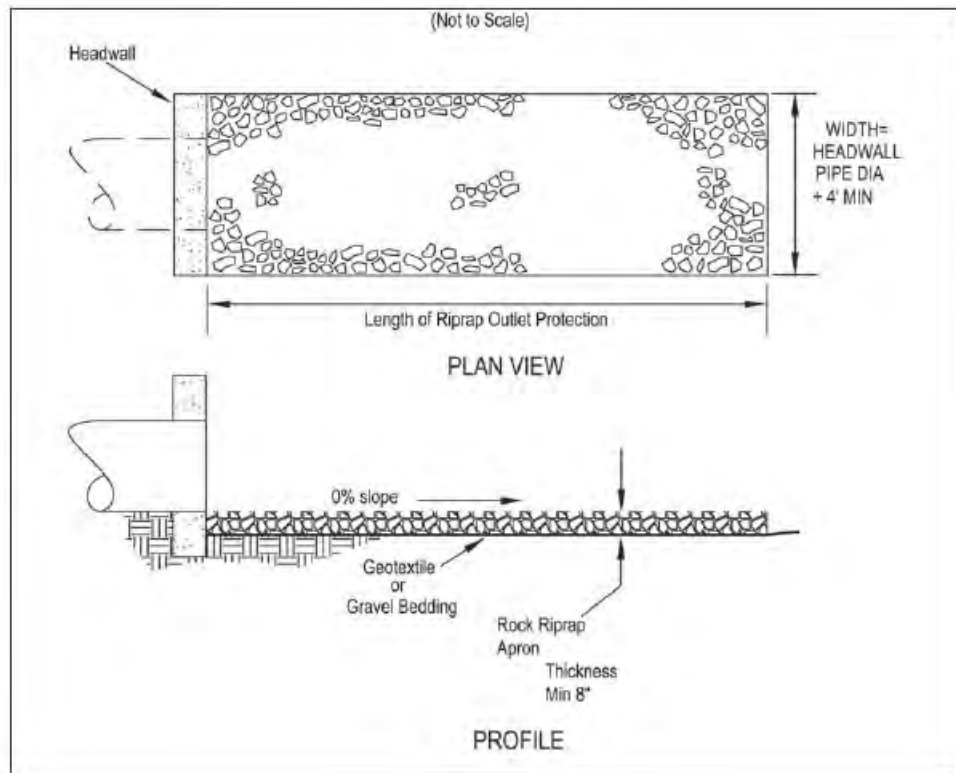
# DETAIL **D-13**

## CULVERT (FLUMED) STREAM CROSSING



## DETAIL D-14

### ROCK OUTLET PROTECTION

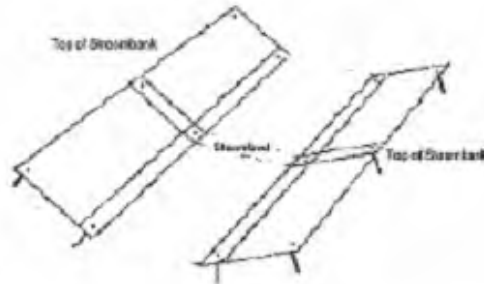


1. Subgrade for the filter or bedding and riprap shall be prepared to the required lines and grades as shown on the plan. The subgrade shall be cleared of all trees, stumps, roots, sod, loose rock, or other material.
2. Riprap shall conform to the grading limits as shown on the plan.
3. Geotextile shall be securely anchored according to manufacturers' recommendations.
4. Geotextile shall be laid with the long dimension parallel to the direction of flow and shall be laid loosely but without wrinkles and creases. Where joints are necessary, strips shall be placed to provide a 12-in. minimum overlap, with the upstream strip overlapping the downstream strip.
5. Gravel bedding shall be ODOT No. 67's or 57's unless shown differently on the drawings.
6. Riprap may be placed by equipment but shall be placed in a manner to prevent slippage or damage to the geotextile.
7. Riprap shall be placed by a method that does not cause segregation of sizes. Extensive pushing with a dozer causes segregation and shall be avoided by delivering riprap near its final location within the channel.
8. Construction shall be sequenced so that outlet protection is placed and functional when the storm drain, culvert, or open channel above it becomes operational.
9. All disturbed areas will be vegetated as soon as practical.

## DETAIL D-15

### STREAM BANK RESTORATION DETAIL

#### Erosion Control Mat Details



Refer to matting manufacturer's installation detail for overlap, embedment, staple patterns, and vegetative stabilization specifications

#### Stream Rip-Rap Details



The following guidelines will be used to select riprap size and thickness:

- For channels with water depth > 3 feet, use R-5 at 6" thick.
- For channels with water depth between 2 and 3 feet, use R-4 at 4" thick
- For channels with water depth between 1 and 2 feet, use R-3 at 3" thick
- For channels with water depth < 1 feet, use R-2 at 3" thick



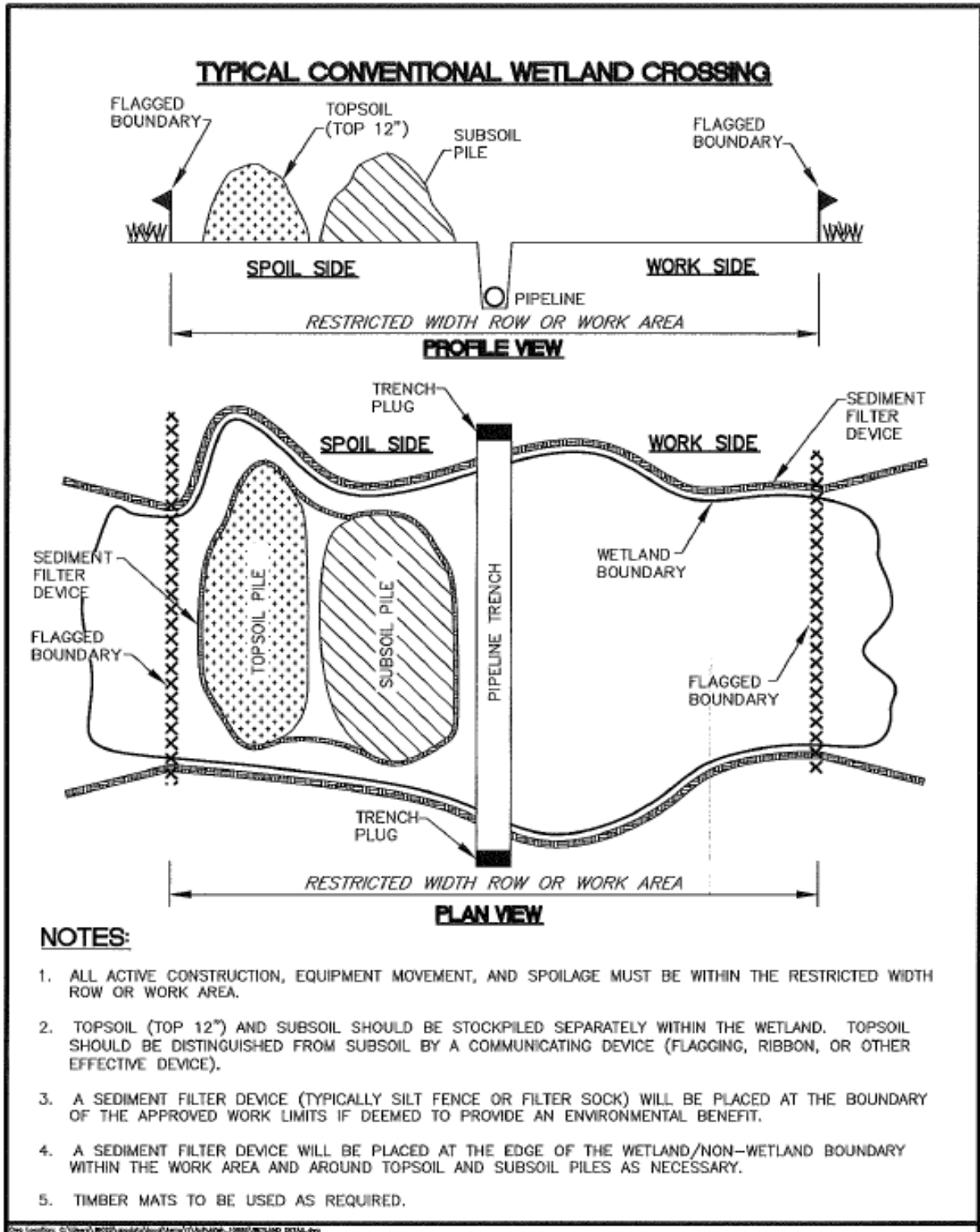
Specifications  
for  
**Stream Utility Crossing**

---

1. When site conditions allow, one of the following shall be used to divert stream flow or keep the flow away from construction activity.
  - Drill or bore the utility lines under the stream channel.
  - Construct a cofferdam or barricade of sheet pilings, sandbags or a turbidity curtain to keep flow from moving through the disturbed area. Turbidity curtains shall be a pre-assembled system and used only parallel to flow.
  - Stage construction by confining first one-half of the channel until work there is completed and stabilized, then move to the other side to complete the crossing.
  - Route the stream flow around the work area by bridging the trench with a rigid culvert, pumping, or constructing a temporary channel. Temporary channels shall be stabilized by rock or a geotextile completely lining the channel bottom and side slopes.
2. Crossing Width -The width of clearing shall be minimized through the riparian area. The limits of disturbance shall be as narrow as possible including not only construction operations within the channel itself but also clearing done through the vegetation growing on the streambanks.
3. Clearing shall be done by cutting NOT grubbing. The roots and stumps shall be left in place to help stabilize the banks and accelerate revegetation.
4. Material excavated from the trench shall be placed at least 20 ft. from the streambanks.
5. To the extent other constraints allow, stream shall be crossed during periods of low flow.
6. Duration of Construction -The time between initial disturbance of the stream and final stabilization shall be kept to a minimum. Construction shall not begin on the crossing until the utility line is in place to within 10 ft. of the streambank.
7. Fill Placed Within the Channel -The only fill permitted in the channel should be clean aggregate, stone or rock. No soil or other fine erodible material shall be placed in the channel. This restriction includes all fill for temporary crossings, diversions, and trench backfill when placed in flowing water. If the stream flow is diverted away from construction activity the material originally excavated from the trench may be used to backfill the trench.
8. Streambank Restorations -Streambanks shall be restored to their original line and grade and stabilized with riprap or vegetative bank stabilization.
9. Runoff Control Along the Right-of-Way -To prevent sediment-laden runoff from flowing to the stream, runoff shall be diverted with water bar or swales to a sediment trapping practice a minimum of 50 ft. from the stream.
10. Sediment laden water from pumping or dewatering or pumping shall not be discharged directly to a stream. Flow shall be routed through a settling pond, dewatering sump or a flat, well-vegetated area adequate for removing sediment before the pumped water reaches the stream.
11. Dewatering operations shall not cause significant reductions in stream temperatures. If groundwater is to be discharged in high volumes during summer months, it shall first be routed through a settling pond or overland through a flat well-vegetated area.
12. Permits -In addition to these specifications, stream crossings shall conform to the rules and regulations of the U.S. Army Corps of Engineers for in-stream modifications (404 permits) and Ohio Environmental Protection Agency's State Water Quality Certification (401 permits).

# DETAIL D-16

## TYPICAL WETLAND CROSSING





## DETAIL D-17

### WETLAND TIMBER MAT CROSSING

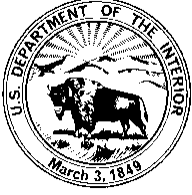




## **Attachment D**

Issued Review letter from SF S, Ohio Department of Natural Resources  
Correspondence, and Mussel Survey

# United States Department of the Interior



## FISH AND WILDLIFE SERVICE

Ecological Services  
4625 Morse Road, Suite 104  
Columbus, Ohio 43230  
(614) 416-8993 / FAX (614) 416-8994



January 26, 2024

Project Code: 2024-0039644

Dear Alyssa Dietz-Oergel:

The U.S. Fish and Wildlife Service (Service) has received your recent correspondence requesting information about the subject proposal. We offer the following comments and recommendations to assist you in minimizing and avoiding adverse impacts to threatened and endangered species pursuant to the Endangered Species Act of 1973 (16 U.S.C. 1531 et seq), as amended (ESA).

Federally Threatened and Endangered Species: Due to the project type, size, location, and the proposed implementation of seasonal tree cutting (clearing of trees  $\geq 3$  inches diameter at breast height between October 1 and March 31) to avoid impacts to the endangered Indiana bat (*Myotis sodalis*) and northern long-eared bat (*Myotis septentrionalis*), and the proposed endangered tricolored bat (*Perimyotis subflavus*) we do not anticipate adverse effects to any other federally endangered, threatened, or proposed species, or proposed or designated critical habitat. Should the project design change, or additional information on listed or proposed species or their critical habitat become available, or if new information reveals effects of the action that were not previously considered, coordination with the Service should be initiated to assess any potential impacts.

Section 7 Coordination: If there is a federal nexus for the project (e.g., federal funding provided, federal permits required to construct), then no tree clearing should occur on any portion of the project area until consultation under section 7 of the ESA, between the Service and the federal action agency, is completed. We recommend the federal action agency submit a determination of effects to this office, relative to the Indiana bat and northern long-eared bat, for our review and concurrence. This letter provides technical assistance only and does not serve as a completed section 7 consultation document.

Stream and Wetland Avoidance: Over 90% of the wetlands in Ohio have been drained, filled, or modified by human activities, thus is it important to conserve the functions and values of the remaining wetlands in Ohio ([https://epa.ohio.gov/portals/47/facts/ohio\\_wetlands.pdf](https://epa.ohio.gov/portals/47/facts/ohio_wetlands.pdf)). We recommend avoiding and minimizing project impacts to all wetland habitats (e.g., forests, streams, vernal pools) to the maximum extent possible in order to benefit water quality and fish and wildlife habitat. Additionally, natural buffers around streams and wetlands should be preserved to enhance beneficial functions. If streams or wetlands will be impacted, the U.S. Army Corps of Engineers should be contacted to determine whether a Clean Water Act section 404 permit is required. Best management practices should be used to minimize erosion, especially on slopes. Disturbed areas should be mulched and revegetated with native plant

species. In addition, prevention of non-native, invasive plant establishment is critical in maintaining high quality habitats.

Thank you for your efforts to conserve listed species and sensitive habitats in Ohio. We recommend coordinating with the Ohio Department of Natural Resources due to the potential for the proposed project to affect state listed species and/or state lands. Contact Mike Pettegrew, Environmental Services Administrator, at (614) 265-6387 or at [mike.pettegrew@dnr.ohio.gov](mailto:mike.pettegrew@dnr.ohio.gov).

If you have questions, or if we can be of further assistance in this matter, please contact our office at (614) 416-8993 or [ohio@fws.gov](mailto:ohio@fws.gov).

Sincerely,

A handwritten signature in blue ink that reads "Scott Hicks". The signature is written in a cursive style.

Scott Hicks  
Acting Field Office Supervisor





# Ohio Department of Natural Resources

MIKE DEWINE, GOVERNOR

MARY MERTZ, DIRECTOR

**Office of Real Estate**  
*John Kessler, Chief*  
2045 Morse Road – Bldg. E-2  
Columbus, OH 43229  
Phone: (614) 265-6621  
Fax: (614) 267-4764

May 25, 2021

Greg Eastridge  
Dominion Resources Services, Inc.  
320 Springside Drive, Suite 320  
Akron, Ohio 44333

**Re:** 21-0336; EOG, Ohio Listed Species Consultation, PIR 2788 Apple Creek pipeline replacement

**Project:** The proposed project involves replacing approximately 1,370 feet of (12) inch natural gas steel pipeline with 1,345 feet of (12) inch steel pipeline under the PIR program.

**Location:** The proposed project is located in the City of Wooster, Wayne County, Ohio.

The Ohio Department of Natural Resources (ODNR) has completed a review of the above referenced project. These comments were generated by an inter-disciplinary review within the Department. These comments have been prepared under the authority of the Fish and Wildlife Coordination Act (48 Stat. 401, as amended; 16 U.S.C. 661 et seq.), the National Environmental Policy Act, the Coastal Zone Management Act, Ohio Revised Code and other applicable laws and regulations. These comments are also based on ODNR's experience as the state natural resource management agency and do not supersede or replace the regulatory authority of any local, state or federal agency nor relieve the applicant of the obligation to comply with any local, state or federal laws or regulations.

**Natural Heritage Database:** The Natural Heritage Database has no records at or within a one-mile radius of the project area.

A review of the Ohio Natural Heritage Database indicates there are no other records of state endangered or threatened plants or animals within the project area. There are also no records of state potentially threatened plants, special interest or species of concern animals, or any federally listed species. In addition, we are unaware of any unique ecological sites, geologic features, animal assemblages, scenic rivers, state wildlife areas, state nature preserves, state or national parks, state or national forests, national wildlife refuges, or other protected natural areas within the project area. The review was performed on the project area you specified in your request as well as an additional one-mile radius. Records searched date from 1980.

Please note that Ohio has not been completely surveyed and we rely on receiving information from many sources. Therefore, a lack of records for any particular area is not a statement that rare species or unique features are absent from that area. Although all types of plant communities have been surveyed, we only maintain records on the highest quality areas.

**Fish and Wildlife:** The Division of Wildlife (DOW) has the following comments.

The DOW recommends that impacts to streams, wetlands and other water resources be avoided and minimized to the fullest extent possible, and that best management practices be utilized to minimize erosion and sedimentation.

The entire state of Ohio is within the range of the Indiana bat (*Myotis sodalis*), a state endangered and federally endangered species, the northern long-eared bat (*Myotis septentrionalis*), a state endangered and federally threatened species, the little brown bat (*Myotis lucifugus*), a state endangered species, and the tricolored bat (*Perimyotis subflavus*), a state endangered species. During the spring and summer (April 1 through September 30), these species of bats predominately roost in trees behind loose, exfoliating bark, in crevices and cavities, or in the leaves. However, these species are also dependent on the forest structure surrounding roost trees. If trees are present within the project area, and trees must be cut, the DOW recommends cutting only occur from October 1 through March 31, conserving trees with loose, shaggy bark and/or crevices, holes, or cavities, as well as trees with DBH  $\geq 20$  if possible. If trees are present within the project area, and trees must be cut during the summer months, the DOW recommends a mist net survey or acoustic survey be conducted from June 1 through August 15, prior to any cutting. Mist net and acoustic surveys should be conducted in accordance with the most recent version of the "OHIO DIVISION OF WILDLIFE GUIDANCE FOR BAT SURVEYS AND TREE CLEARING". <https://ohiodnr.gov/static/documents/wildlife/wildlife-management/Bat+Survey+Guidelines.pdf>

If state listed bats are documented, DOW recommends cutting only occur from October 1 through March 31, however, limited summer tree cutting may be acceptable after consultation with DOW (contact Sarah Stankavich, [sarah.stankavich@dnr.state.oh.us](mailto:sarah.stankavich@dnr.state.oh.us)).

The DOW also recommends that a desktop habitat assessment, followed by a field assessment if needed, is conducted to determine if there are potential hibernaculum(a) present within the project area. Information about how to conduct habitat assessments can be found in the current USFWS "Range-wide Indiana Bat Survey Guidelines." If a habitat assessment finds that potential hibernacula are present within 0.25 miles of the project area, please send this information to Sarah Stankavich, [sarah.stankavich@dnr.state.oh.us](mailto:sarah.stankavich@dnr.state.oh.us) for project recommendations. If a potential or known hibernaculum is found, the DOW recommends a 0.25-mile tree cutting and subsurface disturbance buffer around the hibernaculum entrance, however, limited summer or winter tree cutting may be acceptable after consultation with DOW. If no tree cutting or subsurface impacts to a hibernaculum are proposed, this project is not likely to impact these species.

This project must not have an impact on freshwater native mussels at the project site. This applies to both listed and non-listed species. Per the Ohio Mussel Survey Protocol (2020), all Group 2, 3, and 4 streams (Appendix A) require a mussel survey. Per the Ohio Mussel Survey Protocol, Group 1 streams (Appendix A) and unlisted streams with a watershed of 5 square miles or larger above the point of impact should be assessed using the Reconnaissance Survey for Unionid Mussels (Appendix B) to determine if mussels are present. Mussel surveys may be recommended for these streams as well. This is further explained within the Ohio Mussel Survey Protocol. Therefore, if in-water work is planned in any stream that meets any of the above criteria, the DOW recommends the applicant provide information to indicate no mussel impacts will occur. If this is not possible, the DOW recommends a professional malacologist conduct a mussel survey in the project area. If mussels that cannot be avoided are found in the project area, as a last resort, the DOW recommends a professional malacologist collect and relocate the mussels to suitable and similar habitat upstream of the project site. Mussel surveys and any subsequent mussel relocation should be done in accordance with the Ohio Mussel Survey Protocol. The Ohio Mussel Survey Protocol (2020) can be found at:

<http://wildlife.ohiodnr.gov/portals/wildlife/pdfs/licenses%20&%20permits/OH%20Mussel%20Survey%20Protocol.pdf>

The project is within the range of the lake chubsucker (*Erimyzon sucetta*), a state threatened fish. The DOW recommends no in-water work in perennial streams from March 15 through June 30 to reduce impacts to indigenous aquatic species and their habitat.

The project is within the range of the eastern massasauga (*Sistrurus catenatus*), a state endangered and a federally threatened snake species. The eastern massasauga uses a range of habitats including wet prairies, fens, and other wetlands, as well as drier upland habitat. Due to the location, the type of habitat within the project area, and the type of work proposed, this project is not likely to impact this species.

The project is within the range of the smooth greensnake (*Opheodrys vernalis*), a state endangered species. This species is primarily a prairie inhabitant, but also found in marshy meadows and roadside ditches. Due to the location, the type of habitat within the project area, and the type of work proposed, this project is not likely to impact this species.

The project is within the range of the Kirtland's snake (*Clonophis kirtlandii*), a state threatened species. This secretive species prefers wet meadows and other wetlands. Due to the location, the type of habitat within the project area, and the type of work proposed, this project is not likely to impact this species.

The project is within the range of the American bittern (*Botaurus lentiginosus*), a state endangered bird. Nesting bitterns prefer large undisturbed wetlands that have scattered small pools amongst dense vegetation. They occasionally occupy bogs, large wet meadows, and dense shrubby swamps. If this type of habitat will be impacted, construction should be avoided in this habitat during the species' nesting period of May 1 through July 31. If this type of habitat will not be impacted, this project is not likely to impact this species.

The project is within the range of the black-crowned night-heron (*Nycticorax nycticorax*), a state-threatened bird. Night-herons are so named because they are nocturnal, conducting most of their foraging in the evening hours or at night, and roost in trees near wetlands and waterbodies during the day. Night herons are migratory and are typically found in Ohio from April 1 through December 1 but can be found in more urbanized areas with reliable food sources year-round. Black-crowned night-herons primarily forage in wetlands and other shallow aquatic habitats, and roost in trees nearby. These night-herons nest in small trees, saplings, shrubs, or sometimes on the ground, near bodies of water and wetlands. If this type of habitat will be impacted, construction should be avoided in this habitat during the species' nesting period of May 1 through July 31. If this type of habitat will not be impacted, this project is not likely to impact this species.

The project is within the range of the least bittern (*Ixobrychus exilis*), a state threatened bird. This secretive marsh species prefers dense emergent wetlands with thick stands of cattails, sedges, sawgrass or other semiaquatic vegetation interspersed with woody vegetation and open water. If this type of habitat will be impacted, construction should be avoided in this habitat during the species' nesting period of May 1 through July 31. If this type of habitat will not be impacted, this project is not likely to impact this species.

The project is within the range of the northern harrier (*Circus hudsonis*), a state endangered bird. This is a common migrant and winter species. Nesters are much rarer, although they occasionally breed in large marshes and grasslands. Harriers often nest in loose colonies. The female builds a



nest out of sticks on the ground, often on top of a mound. Harriers hunt over grasslands. If this type of habitat will be impacted, construction should be avoided in this habitat during the species' nesting period of April 15 through July 31. If this habitat will not be impacted, this project is not likely to impact this species.

The project is within the range of the sandhill crane (*Grus canadensis*), a state threatened species. Sandhill cranes are primarily a wetland-dependent species. On their wintering grounds, they will utilize agricultural fields; however, they roost in shallow, standing water or moist bottomlands. On breeding grounds, they require a rather large tract of wet meadow, shallow marsh, or bog for nesting. If grassland, prairie, or wetland habitat will be impacted, construction should be avoided in this habitat during the species' nesting period of April 1 through August 31. If this habitat will not be impacted, this project is not likely to have an impact on this species.

The project is within the range of the trumpeter swan (*Cygnus buccinator*), a state threatened bird. Trumpeter swans prefer large marshes and lakes ranging in size from 40 to 150 acres. They like shallow wetlands one to three feet deep with a diverse mix of plenty of emergent and submergent vegetation and open water. If this type of habitat will be impacted, construction should be avoided in this habitat during the species' nesting period of April 15 through June 15. If this habitat will not be impacted, this project is not likely to have an impact on this species.

Due to the potential of impacts to federally listed species, as well as to state listed species, we recommend that this project be coordinated with the U.S. Fish & Wildlife Service.

**Water Resources:** The Division of Water Resources has the following comment.

The local floodplain administrator should be contacted concerning the possible need for any floodplain permits or approvals for this project. Your local floodplain administrator contact information can be found at the website below.

[http://water.ohiodnr.gov/portals/soilwater/pdf/floodplain/Floodplain%20Manager%20Community%20Contact%20List\\_8\\_16.pdf](http://water.ohiodnr.gov/portals/soilwater/pdf/floodplain/Floodplain%20Manager%20Community%20Contact%20List_8_16.pdf)

ODNR appreciates the opportunity to provide these comments. Please contact Sarah Tebbe, Environmental Specialist, at (614) 265-6397 or [Sarah.Tebbe@dnr.state.oh.us](mailto:Sarah.Tebbe@dnr.state.oh.us) if you have questions about these comments or need additional information.

Mike Pettegrew  
Environmental Services Administrator (Acting)

Apple Creek Mussel Reconnaissance  
Permitting Package  
Apple Creek  
Wayne County, Ohio

**From:** [John.Navarro@dnr.ohio.gov](mailto:John.Navarro@dnr.ohio.gov)  
**To:** [Adam.Benshoff](mailto:Adam.Benshoff)  
**Subject:** RE: Apple Creek - Recon Assessment - Wayne County  
**Date:** Wednesday, September 27, 2023 9:45:22 AM

---

Report accepted, project can proceed.

**John Navarro**

Aquatic Stewardship Program Administrator  
Ohio Department of Natural Resources  
Division of Wildlife  
2045 Morse Rd, Columbus, Ohio 43229  
614-265-6346  
[John.navarro@dnr.state.oh.us](mailto:John.navarro@dnr.state.oh.us)

---

**From:** Adam Benshoff <akbenshoff@edge-es.com>  
**Sent:** Wednesday, September 27, 2023 8:39 AM  
**To:** Navarro, John <John.Navarro@dnr.ohio.gov>  
**Subject:** Apple Creek - Recon Assessment - Wayne County

Good morning,

EDGE Engineering and Science performed a second reconnaissance survey at a Dominion Pipeline project location in Apple Creek on September 16, 2023, during optimal survey conditions. Max depths within the survey area were 3 ft and the entire survey reach was visible to bottom. Substrates throughout the downstream reach were stable with riffle substrates composed of cobble and some boulder. The Project area and upstream buffer were composed of smaller and mobile substrates. The entire 690 foot stream reach was searched for evidence of freshwater mussels. A total of 4.5 person hours was expended at the project location that resulted in no detection of live or deadshell freshwater mussels.

EDGE respectfully requests concurrence that the project will have no effect on freshwater mussels and may proceed with construction as scheduled.

Thank you in advance and have a great week!

**ADAM K. BENSHOFF**

Project Manager / Senior Malacologist  
Kent, Ohio  
D: 330.931.1832  
[edge-es.com](http://edge-es.com)





**CAUTION:** This is an external email and may not be safe. If the email looks suspicious, please do not click links or open attachments and forward the email to [csc@ohio.gov](mailto:csc@ohio.gov) or click the Phish Alert Button if available.

# HABITAT ASSESSMENT FORM

---

# Ohio Mussel Habitat Assessment Form

## Project Information

Project Name: Apple Creek Recon  
County: Wayne Township: Wooster  
Latitude (DD.DDDD): 40.80302 Longitude (DD.DDDD): -81.89981  
Stream Name: Apple Creek Group # (From Appendix A): Unlisted

## Methods

Name of Surveyor(s): Adam Benschhoff; Jacob Miller  
Qualification of Surveyor(s):  USFWS Approved  ODNR Approved  Aquatic Biologist (minimum)  
Date of Survey: 9/16/2023 Distance Surveyed (ft.): 690 ft  
Total Survey Time (min. x people): 570 Scientific Collector's Permit Number(s): \_\_\_\_\_

Note any deviations from the Ohio Mussel Habitat Assessment Methods:

None

## Habitat Description of Survey Area

Drainage Area at Survey Location (mi<sup>2</sup>): 32 Water Temp. (°F): 55 Air Temp. (°F): 73

Substrate Types (include %):

<input type="checkbox"/> Boulder <u>5</u>	<input type="checkbox"/> Gravel <u>35</u>	<input type="checkbox"/> Bedrock _____	<input type="checkbox"/> Detritus _____	<input type="checkbox"/> Silt <u>15</u>
<input type="checkbox"/> Cobble <u>15</u>	<input type="checkbox"/> Sand <u>30</u>	<input type="checkbox"/> Hardpan _____	<input type="checkbox"/> Muck _____	<input type="checkbox"/> Artificial _____

Water Level:  High  Up  Normal  Low  Dry/Interstitial

Visibility:  0-15 cm  15-30 cm  30-50 cm  >50 cm  Visible to Bottom

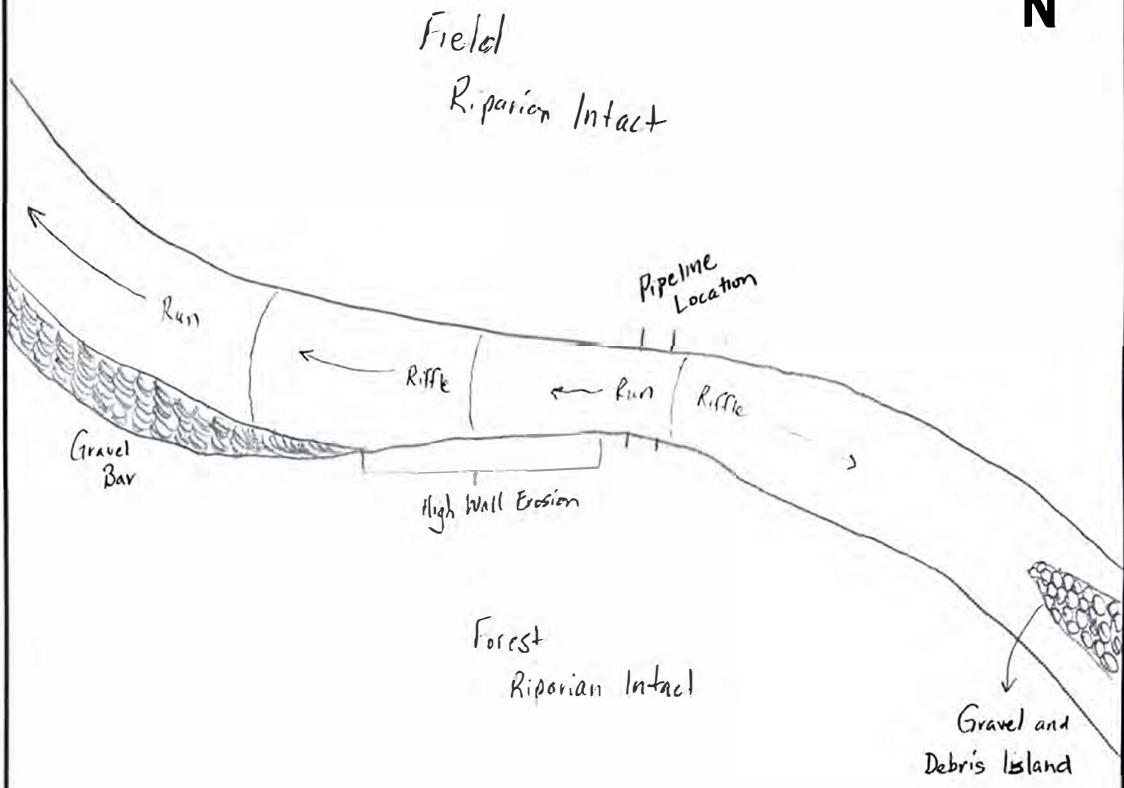
Average Depth (cm): Riffle 5 Run 15 Pool 40

Max Depth (cm): Riffle 15 Run 30 Pool 55



# Mussel Survey Data Sheet

## Section F: Sketch of Survey Reach



### NOTES

Downstream Riffle has larger substrates  
Runs are slow with smaller substrates that are spongy and appear mobile

## **SITE PHOTOS**

---



Apple Creek Downstream Extent



Apple Creek Riffle with Erosion





Apple Creek at Project Location



Apple Creek Upstream Extent





Run Habitat

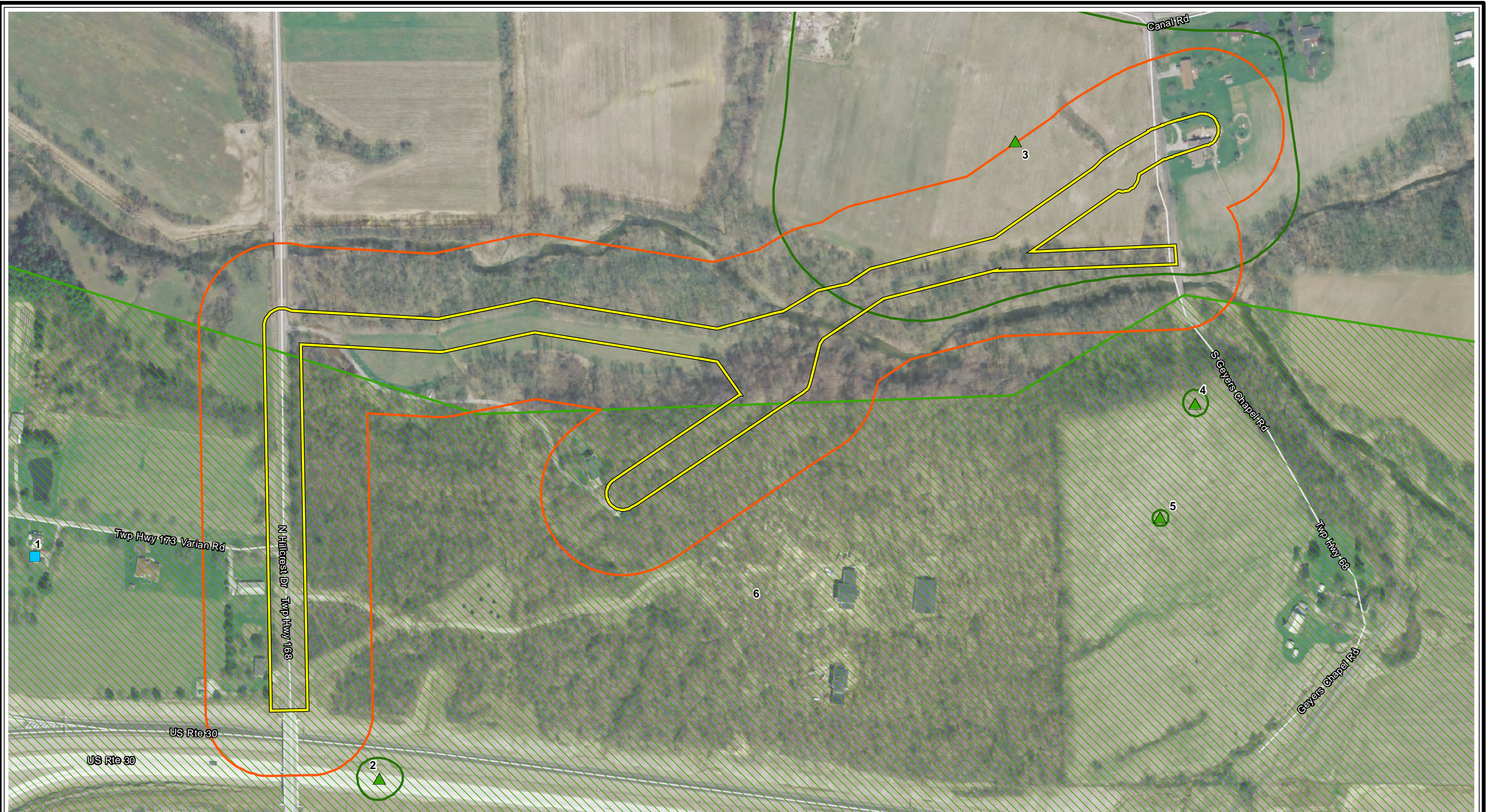


Habitat at Project Location

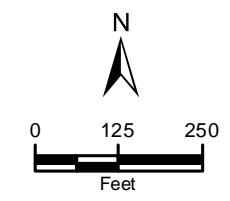
**Attachment E**

Ohio Historic Preservation Office Literature Review Map





- Project Study Area
- 200-Foot Study Area Buffer
- Historic Structures
- Archaeological Sites
- OAI Site Boundaries
- Phase 1 Archaeological Survey



Base Layer: OSIP Aerial, 2016

**Figure 2**  
**Cultural Resources**  
 PIR 2788 - Apple Creek  
 Dominion Energy Ohio  
 Wayne County, Ohio  
 Date: 1/17/2024





**PIR 2788-Apple Creek**  
**Wooster Township, Wayne County**  
**Ohio Historic Preservation Office Cultural Resource Data Sheet**

	<b>Zone</b>	<b>OHI Number</b>	<b>Present Name</b>	<b>Other Name</b>	<b>Address</b>	<b>Place Name</b>	<b>Architectural Style 1</b>	<b>Arch. Style 2</b>	<b>Historic Use</b>	<b>Date</b>
1	17	WAY0030013	William Pearce House	Riffel Dairy Farm	2795 Varian Road	Wooster	Vernacular	N/A	Single Dwelling	1840



**PIR 2788-Apple Creek**  
**Wooster Township, Wayne County**  
**Ohio Historic Preservation Office Cultural Resource Data Sheet**

Ohio Archaeological Inventory Isolated Find Form									
	Site Number	UTM Coordinate	Easting	Northing	Date of Form	Artifact Description	Author 1	Author 2	Institution
2	33-We-448	17	423698	4516647	Aug-94	chert flakes, biface fragment	David R. Bush	N/A	The CCRR
3	33-WE-85	17	424240	4516270	28856	None by this survey, D. W. Taggart collected charcoal, FCR, chert debitage and limited tools from testing he conducted in 1960.	John DeWert	Jeffrey Gardner	OHS Archaeology
4	33-WE-370	17	424460	4516980	34759	Six (6) chert flakes, One (1) glass fragment	David R. Bush	n/a	The CCRR
5	33-WE-371	17	424420	4516860	34759	One (1) chert flake	David R. Bush	n/a	The CCRR





**PIR 2788-Apple Creek**  
**Wooster Township, Wayne County**  
**Ohio Historic Preservation Office Cultural Resource Data Sheet**

Phase 1 Survey Areas									
	NADB	LOG	Acres	Area	Phase	Title	Author 1	Author 2	Sent From
6	16129	969239	3893.05	1	1	Phase II Cultural Resource Investigation of the Proposed WAY-30-11.86 Project, Wayne County, Ohio.	Bush, David R.	Mark A. Kollecker, Rebecca M. Rodgers, Barbara J. Gundy, and Jonathan Glenn	Center for Cultural Resource Research



**ATTACHMENT N**  
**TRANSMITTAL LETTER TO PUBLIC OFFICIALS**

**whittsturtevant** LLP

**MARK A. WHITT**  
Direct: 614.224.3911  
whitt@whitt-sturtevant.com

<DATE>

*Via FedEx*

Steve Miller  
Wooster Twp Trustee President  
838 Heyl Rd  
Wooster, OH 44691

Mike Lindeman  
Wooster Twp Trustee  
838 Heyl Rd  
Wooster, OH 44691

Wayne Soil & Water  
Conservation District  
428 W Liberty St  
Wooster, OH 44691

Matt Ogden  
Wooster Twp Trustee  
838 Heyl Rd  
Wooster, OH 44691

**Re: Dominion Energy Ohio Letter of Notification for PIR 2788 – Apple Creek, Wooster Township, Wayne County, Ohio Case No. 24-0166-GA-BNR**

Dear Public Official,

The East Ohio Gas Company d/b/a Dominion Energy Ohio (“DEO”) is preparing for the replacement of approximately 3,100 feet of 12-inch pipeline with approximately 3,880 feet of 12-inch diameter and 20 feet of 16-inch diameter fusion bond epoxy (“FBE”) steel pipeline. Both the existing and replacement pipe are located entirely within the public right-of-way in Wooster Township, Wayne County, Ohio. Upon completion of the project, the existing pipe will be abandoned in place. Existing public roadways and easements will provide the required equipment access.

In accordance with Ohio Revised Code Section 4906.03(F)(3), this project falls within the Ohio Power Siting Board’s (Board) jurisdiction. Therefore, in compliance with Ohio Administrative Code Rule 4906-6-07(A)(1), enclosed please find a copy of the Construction Notification application that has been filed with the Board for its review and approval.

If you have any questions concerning this pipeline replacement project, please contact Dominion Energy Ohio’s Land Services Department at 1-855-226-6022.

Sincerely,



Mark A. Whitt

Enclosure: Copy of Construction Notification Application

cc: Wayne County Public Library